

# Autonics COUNTER / TIMER FXY SERIES

## INSTRUCTION MANUAL



Thank you for choosing our Autonics product.  
Please read the following safety considerations before use.

### Safety Considerations

- ※Please observe all safety considerations for safe and proper product operation to avoid hazards.
- ※Safety considerations are categorized as follows.
- Warning** Failure to follow these instructions may result in serious injury or death.
- Caution** Failure to follow these instructions may result in personal injury or product damage.
- ※The symbols used on the product and instruction manual represent the following
- ⚠ symbol represents caution due to special circumstances in which hazards may occur.

### Warning

- Fail-safe device must be installed when using the unit with machinery that may cause serious injury or substantial economic loss.** (e.g. nuclear power control, medical equipment, ships, vehicles, railways, aircraft, combustion apparatus, safety equipment, crime/disaster prevention devices, etc.)  
Failure to follow this instruction may result in fire, personal injury, or economic loss.
- Install on a device panel to use.**  
Failure to follow this instruction may result in electric shock or fire.
- Do not connect, repair, or inspect the unit while connected to a power source.**  
Failure to follow this instruction may result in electric shock or fire.
- Check 'Connections' before wiring.**  
Failure to follow this instruction may result in fire.
- Do not disassemble or modify the unit.**  
Failure to follow this instruction may result in electric shock or fire.

### Caution

- When connecting the power/sensor input, use AWG 20(0.50mm<sup>2</sup>) cable or over, and tighten the terminal screw with a tightening torque of 0.74 to 0.90N·m.**  
Failure to follow this instruction may result in fire or malfunction due to contact failure.
- Use the unit within the rated specifications.**  
Failure to follow this instruction may result in fire or product damage.
- Use dry cloth to clean the unit, and do not use water or organic solvent.**  
Failure to follow this instruction may result in electric shock or fire.
- Do not use the unit in the place where flammable/explosive/corrosive gas, humidity, direct sunlight, radiant heat, vibration, impact, or salinity may be present.**  
Failure to follow this instruction may result in fire or explosion.
- Keep metal chip, dust, and wire residue from flowing into the unit.**  
Failure to follow this instruction may result in fire or product damage.

### Dimensions

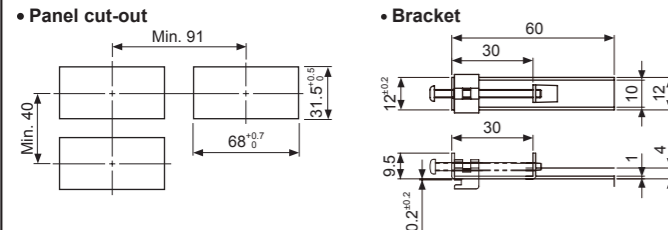
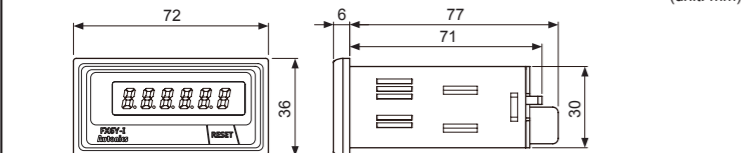

### Connections

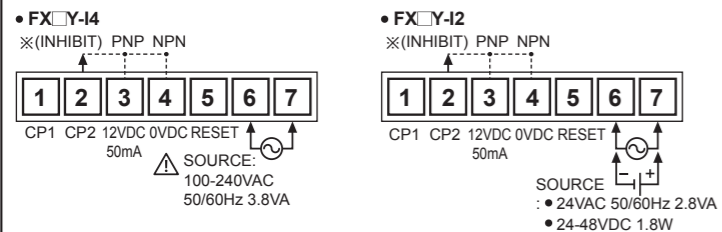

※INHIBIT: In case of timer mode, this terminal is for time hold.  
(voltage input (PNP): connect with 12VDC, non-voltage input (NPN): connect with 0VDC)

※The above specifications are subject to change and some models may be discontinued without notice.

※Be sure to follow cautions written in the instruction manual and the technical descriptions (catalog, homepage).

### Model

Model	Display digit	Size	Output	Power supply
FX4Y-12	9999 (4-digit)	DIN W72×H36mm	Indicator	24VAC 50/60Hz, 24-48VDC
FX4Y-14	9999 (4-digit)			100-240VAC 50/60Hz
FX6Y-12	999999 (6-digit)	DIN W72×H36mm	Indicator	24VAC 50/60Hz, 24-48VDC
FX6Y-14				100-240VAC 50/60Hz

### Specifications

Model	Indicator	FX4Y-12	FX4Y-14	FX6Y-12	FX6Y-14
Display digit		4-digit	4-digit	6-digit	6-digit
Character size (W×H)		8×14mm	8×14mm	4×8mm	4×8mm
Power supply		24VAC~50/60Hz, 24-48VDC=	100-240VAC~ 50/60Hz	24VAC~50/60Hz, 24-48VDC=	100-240VAC~ 50/60Hz
Permissible voltage range		90 to 110% of rated voltage			
Power consumption		Max. 2.8VA (24VAC~50/60Hz), Max. 1.8W (24-48VDC=)	Max. 3.8VA (240VAC~50/60Hz)	Max. 2.8VA (24VAC~50/60Hz), Max. 1.8W (24-48VDC=)	Max. 3.8VA (240VAC~50/60Hz)
Max. counting speed of CP1/CP2		Selectable 1cps/30cps/2kcps/5kcps (DIP switch)			
Return time		Max. 500ms			
Min. signal width		INHIBIT, RESET: approx. 20ms			
Input method		Selectable voltage input (PNP) method or no-voltage input (NPN) method [Voltage input (PNP) method]-input impedance: max. 10.8kΩ, [H]: 5-30VDC=, [L]: 0-2VDC [No-voltage input (NPN) method]-short-circuit impedance: max. 470Ω, short-circuit residual voltage: max. 1VDC, open-circuit impedance: min. 100kΩ			
Repeat/Set/Voltage/Temp. error		Max. ±0.01% ±0.05 sec			
Insulation resistance		Over 100MΩ (at 500VDC megger)			
External power supply		Max. 12VDC= ±10% 50mA			
Memory retention		Approx. 10 years (non-volatile memory)			
Dielectric strength		2,000VAC 50/60Hz for 1 min (between all terminals and case)			
Noise immunity		AC voltage ±2kV the square wave noise (pulse width 1μs) by noise simulator Mechanical ±500V the square wave noise (pulse width 1μs) by noise simulator			
Vibration	Mechanical	0.75mm amplitude at frequency 10 to 55Hz (for 1 min) in each X, Y, Z direction for 1 hour			
	Malfunction	0.5mm amplitude at frequency 10 to 55Hz (for 1 min) in each X, Y, Z direction for 10 minutes			
Shock	Mechanical	300m/s <sup>2</sup> (approx. 30G) in each X, Y, Z direction for 3 times			
	Malfunction	100m/s <sup>2</sup> (approx. 10G) in each X, Y, Z direction for 3 times			
Environment	Ambient temp.	-10 to 55°C, storage: -25 to 65°C			
	Ambient humi.	35 to 85%RH, storage: 35 to 85%RH			
Protection structure		IP40 (front part, IEC standard)			
Approval		CE, RoHS			
Weight <sup>※1</sup>		Approx. 175g (approx. 120g)			

※1: The weight includes packaging. The weight in parenthesis is for unit only.  
※Environment resistance is rated at no freezing or condensation.

### Input Connection

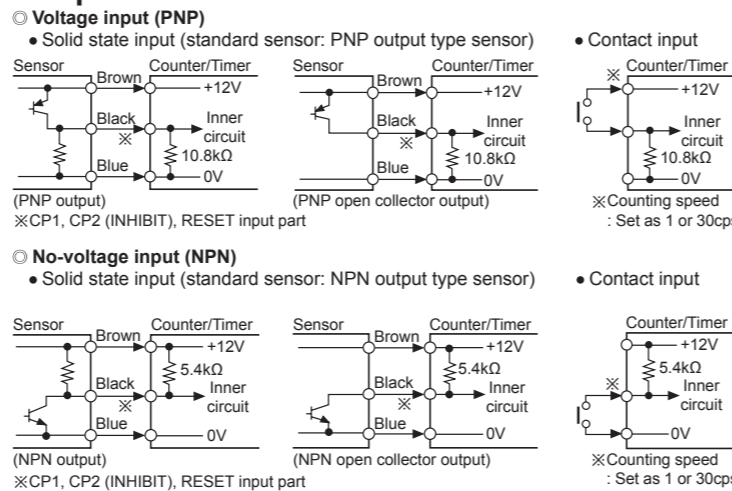

### Dot for Decimal Point / Hour. Min. Second

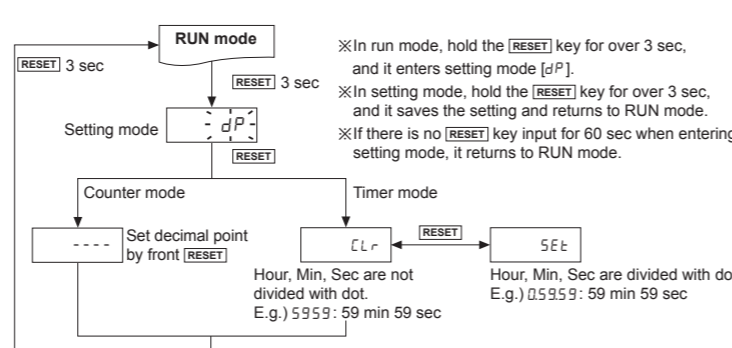

### DIP Switch Setting

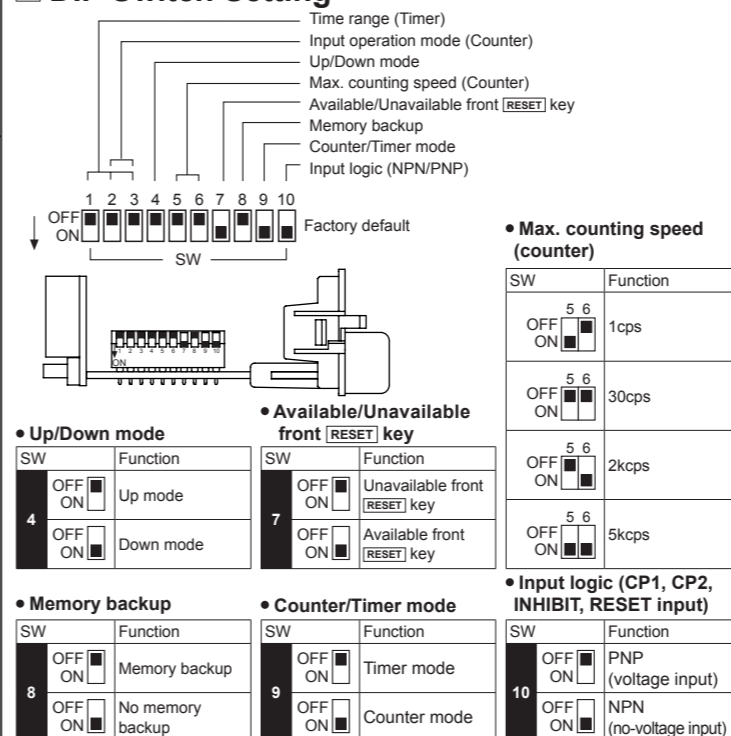

※How to change settings  
Power OFF → change settings → power ON → press [RESET] key or input signal (min. 20ms)

### Input Operation Mode (Counter)

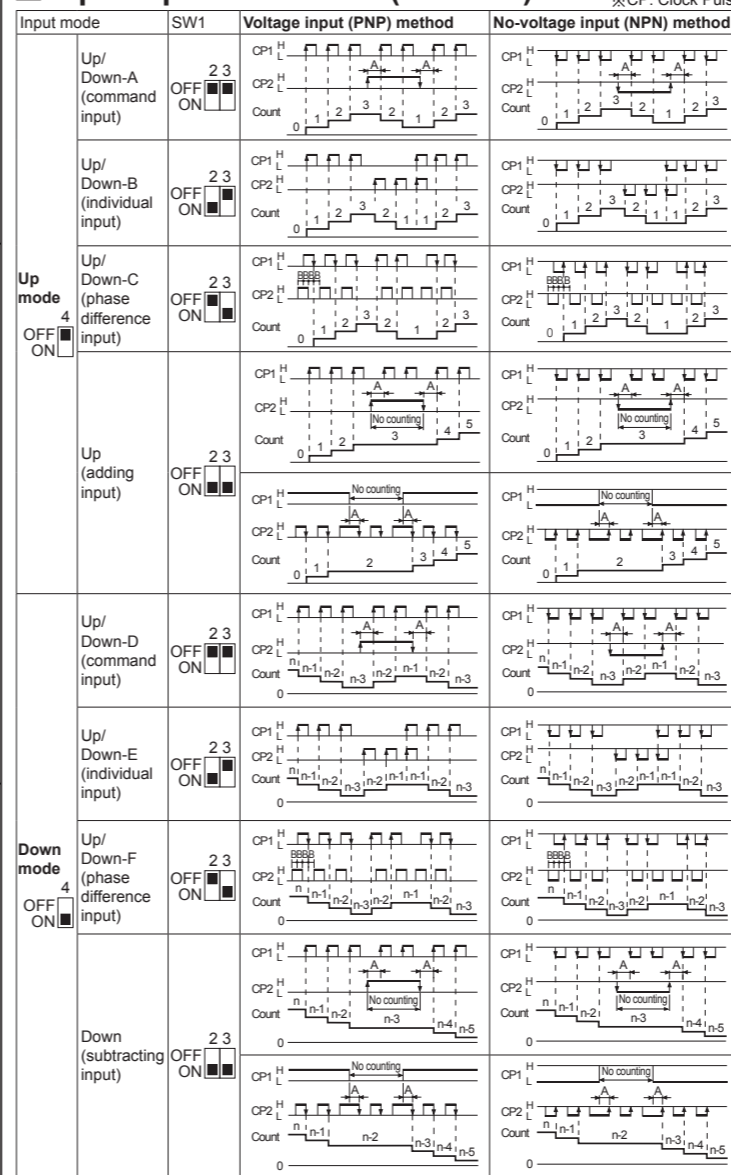

※A: over min. signal width, B: over than 1/2 of min. signal width.  
If the signal is smaller than these width, it may cause counting error (±1).  
※n: +Max. display value (FX4Y-I: 9999, FX6Y-I: 999999)

### Detaching Case

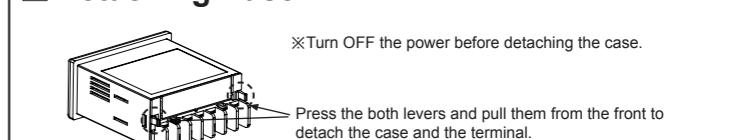

### Time Range (Timer)

SW	4-digit	6-digit	SW	4-digit	6-digit
OFF	99.99sec	99999.9sec	OFF	999.9min	99999.9min
ON	999.9sec	999999sec	ON	99hour 59min	99hour 59min 59sec
OFF	9999sec	99min 59.99sec	OFF	999.9hour	9999hour 59min
ON	99min 59sec	999min 59.9sec	ON	9999hour	99999.9hour

### Counting & Time Operation

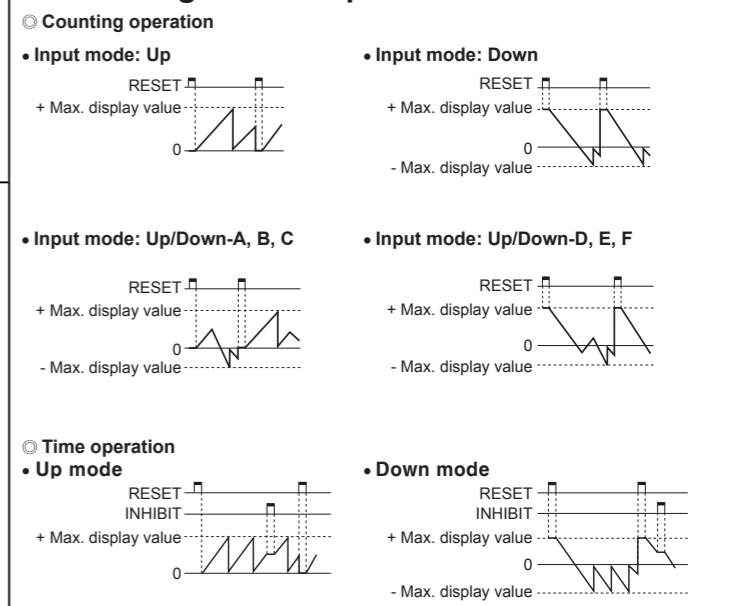

### Cautions during Use

- Follow instructions in 'Cautions during Use'. Otherwise, It may cause unexpected accidents.
- 24-48VDC, 24VAC power supply should be insulated and limited voltage/current or Class 2, SELV power supply device.
- Use the product, 0.1 sec after supplying power.
- When supplying or turning off the power, use a switch or etc. to avoid chattering.
- Install a power switch or circuit breaker in the easily accessible place for supplying or disconnecting the power.
- In case of contact input, set count speed to low speed mode (1cps or 30cps) to operate. If set to high speed mode (2kcps or 5kcps), counting error occurs due to chattering.
- Keep away from high voltage lines or power lines to prevent inductive noise. In case installing power line and input signal line closely, use line filter or varistor at power line and shielded wire at input signal line.  
Do not use near the equipment which generates strong magnetic force or high frequency noise.
- This product may be used in the following environments.
  - Indoors (in the environment condition rated in 'Specifications')
  - Altitude max. 2,000m
  - Pollution degree 2
  - Installation category II

### Major Products

- Photoelectric Sensors
- Fiber Optic Sensors
- Door Sensors
- Door Side Sensors
- Area Sensors
- Proximity Sensors
- Pressure Sensors
- Rotary Encoders
- Connector/Sockets
- Switching Mode Power Supplies
- Control Switches/Lamps/Buzzers
- I/O Terminal Blocks & Cables
- Stepper Motors/Drivers/Motion Controllers
- Graphic/Logic Panels
- Field Network Devices
- Laser Marking System (Fiber, Co., Nd: YAG)
- Laser Welding/Cutting System
- Temperature Controllers
- Temperature/Humidity Transducers
- SSR/Power Controllers
- Counters
- Timers
- Panel Meters
- Tachometer/Pulse (Rate) Meters
- Display Units
- Sensor Controllers

**Autonics Corporation**  
http://www.autonics.com

HEAD QUARTERS:  
18, Bansong-ro 513 beon-gil, Haeundae-gu, Busan, South Korea, 48002  
TEL: 82-51-519-3232  
E-mail: sales@autonics.com