

**Autonics**

**Photoelectric Sensor  
BJ SERIES  
(Connector type)**

**INSTRUCTION MANUAL**



Thank you for choosing our Autonics product.  
Please read the following safety considerations before use.

**■ Safety Considerations**

- ※ Please observe all safety considerations for safe and proper product operation to avoid hazards.
- ※ ⚠ symbol represents caution due to special circumstances in which hazards may occur.
- ⚠ Warning** Failure to follow these instructions may result in serious injury or death.
- ⚠ Caution** Failure to follow these instructions may result in personal injury or product damage.

**⚠ Warning**

- Fail-safe device must be installed when using the unit with machinery that may cause serious injury or substantial economic loss.** (e.g. nuclear power control, medical equipment, ships, vehicles, railways, aircraft, combustion apparatus, safety equipment, crime/disaster prevention devices, etc.) Failure to follow this instruction may result in fire, personal injury, or economic loss.
- Do not disassemble or modify the unit.** Failure to follow this instruction may result in fire.
- Do not connect, repair, or inspect the unit while connected to a power source.** Failure to follow this instruction may result in fire.
- Check 'Connections' before wiring.** Failure to follow this instruction may result in fire.

**⚠ Caution**

- Use the unit within the rated specifications.** Failure to follow this instruction may result in fire or product damage.
- Use dry cloth to clean the unit, and do not use water or organic solvent.** Failure to follow this instruction may result in fire.
- Do not use the unit in the place where flammable/explosive/corrosive gas, humidity, direct sunlight, radiant heat, vibration, impact, or salinity may be present.** Failure to follow this instruction may result in fire or explosion.

**■ Ordering Information**

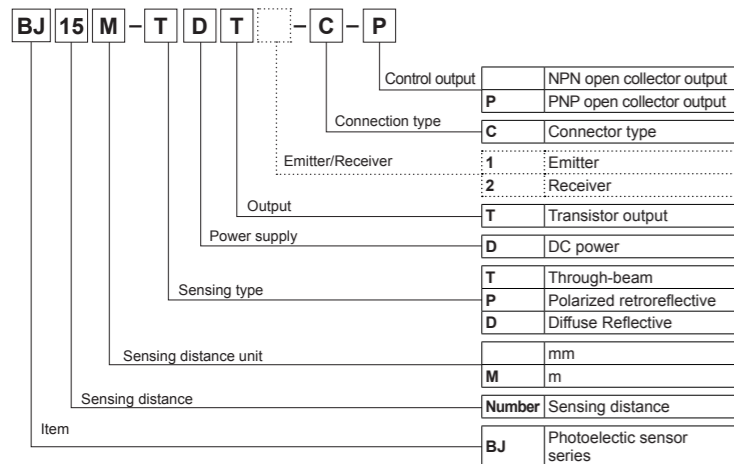

※ This information is intended for product management of through-beam type models. (No need to refer when selecting a model.)  
 ※ The above specifications are subject to change and some models may be discontinued without notice.  
 ※ Be sure to follow cautions written in the instruction manual and the technical descriptions (catalog, homepage).

**■ Specifications**

Indicator	Through-beam	Polarized retroreflective	Diffuse Reflective
Model	BJ15M-TDT-C BJ15M-TDT-C-P	BJ10M-TDT-C BJ10M-TDT-C-P	BJ3M-PDT-C BJ3M-PDT-C-P BJ1M-DDT-C BJ1M-DDT-C-P BJ300-DDT-C BJ300-DDT-C-P BJ100-DDT-C BJ100-DDT-C-P
Sensing distance	0 to 15m	0 to 10m	0.1 to 3m*1 (MS-2A) 1m (Non-glossy white paper 300×300mm) 300mm (Non-glossy white paper 100×100mm) 100mm (Non-glossy white paper 100×100mm)
Sensing target	Opaque materials of min. ϕ12mm	Opaque materials of min. ϕ75mm	Translucent, opaque materials
Hysteresis	—	—	Max. 20% at sensing distance
Response time	Max. 1ms		
Power supply	12-24VDC ±10% (ripple P-P: max. 10%)		
Power consumption	Emitter, Receiver: max. 20mA		Max. 30mA
Light source	Infrared LED (850nm)	Red LED (660nm)	Red LED (660nm) Infrared LED (850nm) Red LED (660nm) Infrared LED (850nm)
Sensitivity adjustment	Sensitivity adjuster		
Operation mode	Light ON/Dark ON Selectable		
Control output	NPN or PNP Open collector type • Load voltage: max. 28.4VDC • Load current: max. 100mA • Residual voltage - NPN: max. 1VDC, PNP: max. 2.5VDC		
Protection circuit	Reverse polarity protection circuit, output short overcurrent protection circuit		
Indicator	Operation indicator: red, stability indicator: green (emitter of power indicator for through-beam: green)		
Connection	M8 Connector		
Insulation resistance	Over 20MΩ (at 500VDC megger)		
Noise immunity	±240V the square wave noise (pulse width: 1μs) by the noise simulator		
Dielectric strength	1,000VAC 50/60Hz for 1minute		
Vibration	1.5mm or 300m/s <sup>2</sup> amplitude at frequency of 10 to 55Hz (for 1min) in each X, Y, Z direction for 2 hours		
Shock	500m/s <sup>2</sup> in X, Y, Z directions for 3 times		
Ambient illumination	Sunlight: max. 11,000lx, incandescent lamp: max 3,000lx (receiver illumination)		
Ambient Temperature	-25 to 55°C, storage: -40 to 70°C		
Ambient humidity	35 to 85%RH, storage: 35 to 85%RH		
Protection structure	IP67 (IEC standards)		
Material	Case: PBT, LED CAP: PC, Lens: PMMA		
Accessories	Common Mounting bracket, M3 bolt: 4, M3 nut: 4, adjuster screwdriver	Individual —	Reflector (MS-2A) —
Approval	CE		
Unit weight	Approx. 20g	Approx. 30g	Approx. 10g

※ 1: If reflector MS-2S, MS-3S (Sold separately) are used, sensing distance will be lengthened as 0.1 to 4m, 0.1 to 5m.  
 ※ M8 Connector cable: Sold separately (CID408-2, CID408-5, CLD408-2, CLD408-5)  
 Cable: ϕ4mm, 4P, Length: 2m/5m/AWG22, Core wire diameter: 0.08mm, No. of core wire: 60, Insulator out diameter: 1.25mm  
 ※ The temperature or humidity mentioned in Environment indicates a non freezing or condensation environment.

**■ Dimensions**

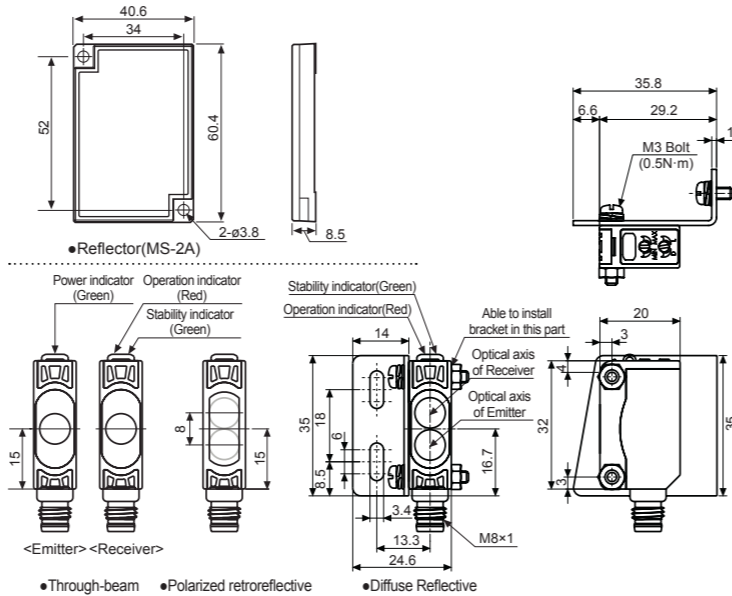

**■ Control Output Circuit Diagram**

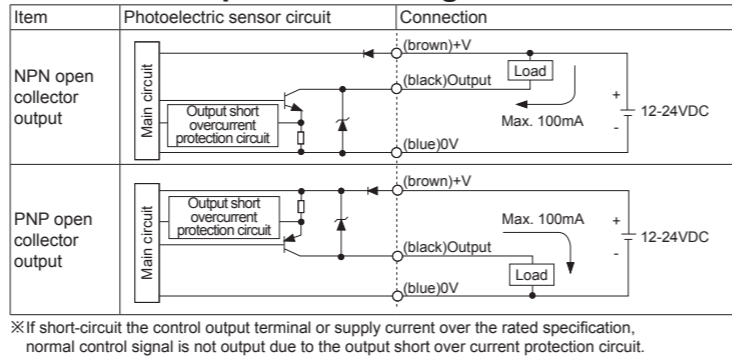

**■ Mounting and Adjustment**

**○ For mounting**  
 When using the reflective type photoelectric sensors closely over three units, it may result in malfunction due to mutual interference.  
 When using the through-beam type photoelectric sensors closely over two units, it may result in malfunction due to mutual interference.  
 When installing the product, tighten the screw with a tightening torque of 0.5N·m.

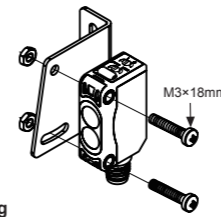

**○ Operation mode switching**

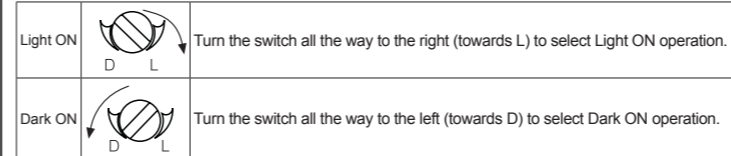

※ For through-beam type, the switch is built-in the receiver.

**○ Optical axis adjustment**

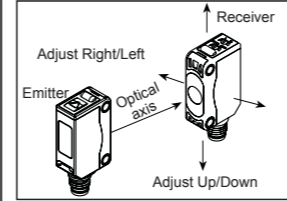

**● Through-beam**

- Supply the power after setting the emitter and the receiver in opposite each other.
- Check the stable indicator operation range with moving or rotating the position of sensor and mirror as right/left and up/down minutely and mount it in the middle of them.
- After mounting, check the normal operation of sensor and lighting of stable indicator with sensing target or without it.  
 ※ If the sensing target is translucent body or smaller than ϕ12mm, it may not sense the target because light is passed.

**● Polarized retroreflective**

- Set sensor and reflector in opposite each other and turn on the power.
- Check the stable indicator operation range with moving or rotating the position of sensor and reflector as right/left and up/down minutely, mount in the middle of it.
- After mounting, check the operation is correct and the lighting of stable indicator with sensing material or without it.

**● Diffuse Reflective**

- Set the sensor and sensing target as shown in the figure left and turn on the power.
- Check the stable indicator operation range with moving or rotating the position of sensor and reflector as right/left and up/down minutely, mount in the middle of it.
- After mounting, check the operation is correct and the lighting of stable indicator with sensing material or without it.

**○ Sensitivity adjustment**

Order	Sensitivity adjuster	Description
1	(A) MIN MAX	Turn the sensitivity adjuster to the right from min. sensitivity position and check (A) where the indicator is turned on in "Light ON status".
2	(A) MIN MAX (B) MIN MAX (C)	Turn the sensitivity adjuster more to the right from min. sensitivity position, check (B) where the indicator is turned on and turn the adjuster to the left, check (C) where the indicator is turned off in "Dark ON status". ※ If the indicator is not lighted although the adjuster is turned to the max. position, the max. position is (C).
3	Optimal sensitivity (A) MIN MAX (C)	Set the adjuster at the center of (A) and (C). Also setting of the optimum sensitivity, check the operation is correct and lighting of stable indicator with sensing target or without it. If the indicator is not lighted, please check the sensing method again because sensitivity is unstable.

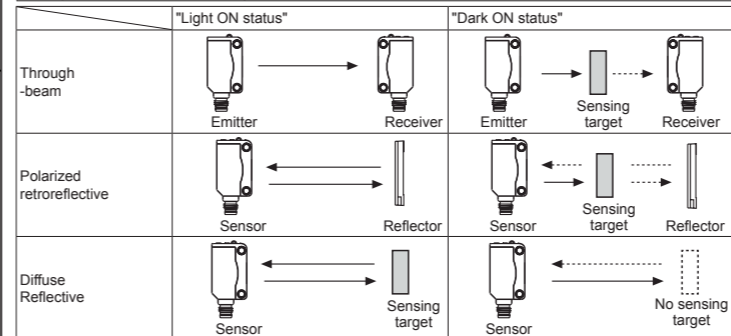

※ Please set the sensitivity setting adjuster is executed in stable Light ON area and the reliability of environment (temperature, supply, dust etc.) is increased after the mounting it in a stable area.  
 ※ When adjusting sensitivity or switching operation modes, please use the Autonics adjustment screwdriver (accessory included). Using a screwdriver with a bigger diameter than the adjuster buttons may cause errors when making adjustments.  
 ※ It may cause breakdown when the sensitivity setting adjuster or the operation mode selection switch is turned by force.

**■ Connections**

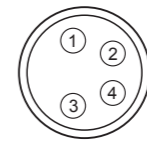

[M8 Connector pin]

Connector in No.	Cable colors	Function
①	Brown	Power Source(+V)
②	White	—
③	Blue	Power Source(0V)
④	Black	Output

※ Connector pin ② is N.C.(Not Connected) terminal.  
 (For through-beam type emitter, terminal no. ② and ④ are N.C (Not Connected) terminal.)

**■ Operation Mode**

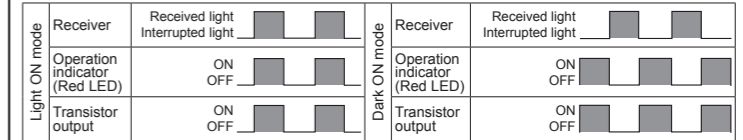

**■ Operation Timing Diagram**

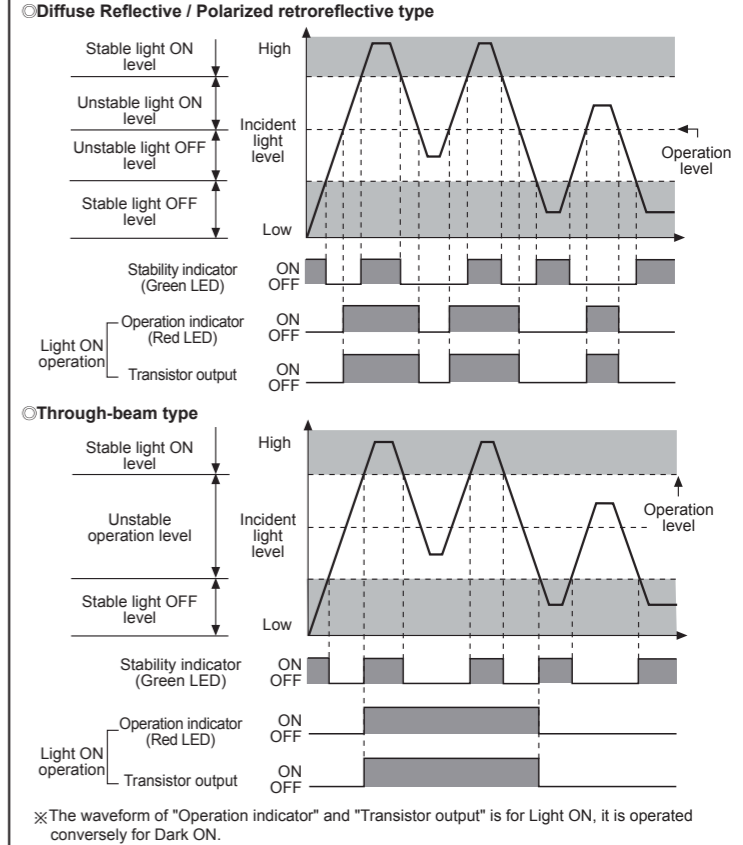

**■ Cautions during Use**

- Follow instructions in 'Cautions during Use'. Otherwise, it may cause unexpected accidents.
- When connecting a DC relay or other inductive load to the output, remove surge by using diodes or varistors.
- Use the product, 0.5 sec after supplying power.  
 When using separate power supply for the sensor and load, supply power to sensor first.
- 12-24VDC power supply should be insulated and limited voltage/current or Class 2, SELV power supply device.
- Wire as short as possible and keep away from high voltage lines or power lines, to prevent inductive noise.
- When using switching mode power supply to supply the power, ground F.G. terminal and connect a condenser between 0V and F.G. terminal to remove noise.
- When using sensor with the equipment which generates noise (switching regulator, inverter, servo motor, etc.), ground F.G. terminal of the equipment.
- This unit may be used in the following environments.
  - ①Indoors (in the environment condition rated in 'Specifications')
  - ②Altitude max. 2,000m
  - ③Pollution degree 3
  - ④Installation category II

**■ Major Products**

- Photoelectric Sensors
- Fiber Optic Sensors
- Door Sensors
- Door Side Sensors
- Area Sensors
- Proximity Sensors
- Pressure Sensors
- Rotary Encoders
- Connectors/Sockets
- Switching Mode Power Supplies
- Control Switches/Lamps/Buzzers
- I/O Terminal Blocks & Cables
- Stepper Motors/Drivers/Motion Controllers
- Graphic/Logic Panels
- Field Network Devices
- Laser Marking System (Fiber, CO<sub>2</sub>, Nd: YAG)
- Laser Welding/Cutting System
- Temperature Controllers
- Temperature/Humidity Transducers
- SSRs/Power Controllers
- Counters
- Timers
- Panel Meters
- Tachometer/Pulse (Rate) Meters
- Display Units
- Sensor Controllers

**Autonics Corporation**  
<http://www.autonics.com>

**HEADQUARTERS:**  
 18, Bansong-ro 513 beon-gil, Haeundae-gu, Busan, South Korea, 48002  
 TEL: 82-51-519-3232  
 E-mail: sales@autonics.com