

Photoelectric Sensor for PCB detection

■ Features

- 30mm×3mm of rectangular light beam (at 30mm distance) provides accurate detection of PCBs regardless of holes, incomplete fabrication, protrusions, or intrusions on the boards.
- Background suppression (BGS) sensing method allows stable detection regardless of the color, texture or surface of the background object.
- Sensing distance: 10 to 100mm (adjustable distance: 20 to 100mm)
- Light ON / Dark ON operation mode switch
- Power reverse polarity protection circuit, Output short over current protection circuit
- IP65 protection structure (IEC standard)



⚠ Please read "Safety Considerations" in instruction manual before using.



■ Model

Model	Application	Sensing distance	Sensing type	Power supply	Output type	Control output
BJP100-BDT	For PCB detection	100mm	BGS reflective type	12-24VDC	Transistor output	NPN open collector output
BJP100-BDT-P						PNP open collector output

■ Specifications

Model	NPN open collector output	BJP100-BDT
	PNP open collector output	BJP100-BDT-P
Sensing type		BGS reflective
Sensing distance ^{※1}		10 to 100mm (at setting distance: 100mm)
Available setting distance ^{※1}		20 to 100mm
Hysteresis ^{※1}		Max. 10% of setting distance
Sensing target		Opaque
Response time		Max. 1.5ms
Power supply		12-24VDC \pm 10% (ripple P-P: max. 10%)
Current consumption		Max. 30mA
Light source		Red LED (660nm)
Distance setting		Distance setting adjuster
Operation mode		Light ON/Dark ON selectable by switch
Control output		NPN or PNP open collector output • Load voltage: max. 26.4VDC \pm • Load current: max. 100mA • Residual voltage - NPN: max. 1VDC \pm , PNP: max. 2VDC
Protection circuit		Power reverse polarity protection circuit, output short over current protection circuit
Indicator		Operation indicator: red LED, stability indicator: green LED
Connection		Cable type
Insulation resistance		Over 20M Ω (at 500VDC megger)
Noise immunity		\pm 240V of square wave noise (pulse width: 1 μ s) by the noise simulator
Dielectric strength		1,000VAC at 50/60Hz for 1min
Vibration		1.5mm amplitude at 10 to 55Hz frequency in each X, Y, Z direction for 2 hours
Shock		500m/s ² (approx. 50G) in each X, Y, Z direction for 3 times
Environment	Ambient illumination	Sunlight: max. 10,000lx, Incandescent lamp: max. 3,000lx (receiver illumination)
	Ambient temperature	-20 to 55°C, storage: -40 to 70°C
	Ambient humidity	35 to 85%RH, storage: 35 to 85%RH
Protection structure		IP65 (IEC standard)
Material		Case: polycarbonate+acrylonitrile butadiene styrene, LED indicator: polycarbonate, sensing part: polymethyl methacrylate
Cable		\varnothing 3.5mm, 3-wire, 2m (AWG 24, core wire diameter: 0.08mm, no. of core wires: 40, insulator diameter: \varnothing 1mm)
Accessories		Adjustment screwdriver, bracket A, M3 bolts: 2, M3 nuts: 2
Approval		CE
Weight ^{※2}		Approx. 105g (approx. 50g)

※1: Non-glossy white paper 100×100mm.

※2: The weight includes packaging. The weight in parenthesis is for unit only.

※Beam spot size is approx. 30×3mm (width×height, at distance: 30mm).

※The temperature and humidity of environment resistance is rated at non-freezing or condensation.

Photoelectric Sensor for PCB detection

Feature Data

◎ BGS reflective type

● BJP100-BDT(-P)

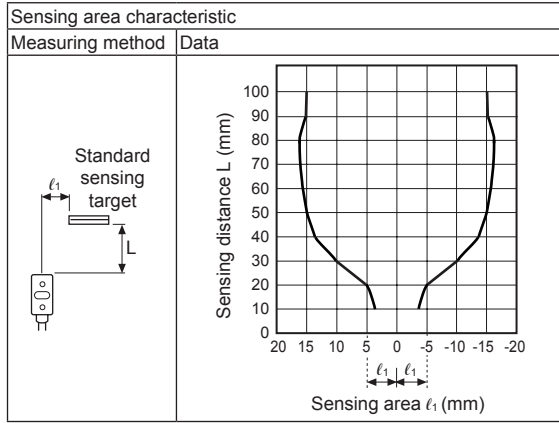

Connections

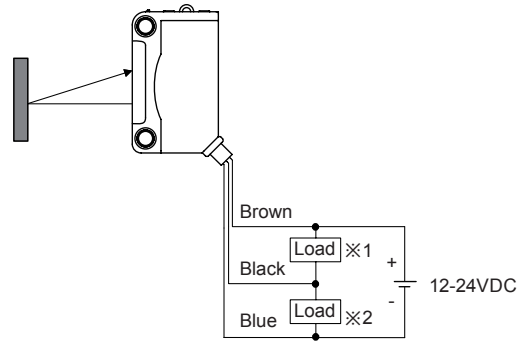

※1: Load connection of NPN open collector output
 ※2: Load connection of PNP open collector output

Control Output Circuit Diagram

● NPN open collector output

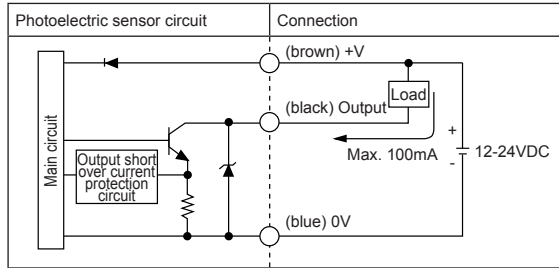



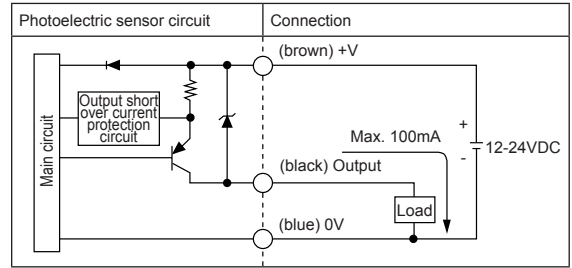









● PNP open collector output

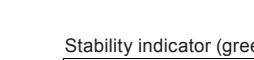

※If short-circuit the control output terminal or supply current over the rated specification, normal control signal is not output due to the output short over current protection circuit.

Operation Mode

Operation mode	Light ON	Dark ON
Receiver operation	Received light  Interrupted light 	Received light  Interrupted light 
Operation indicator (red LED)	ON  OFF 	ON  OFF 
Transistor output	ON  OFF 	ON  OFF 

Dimensions

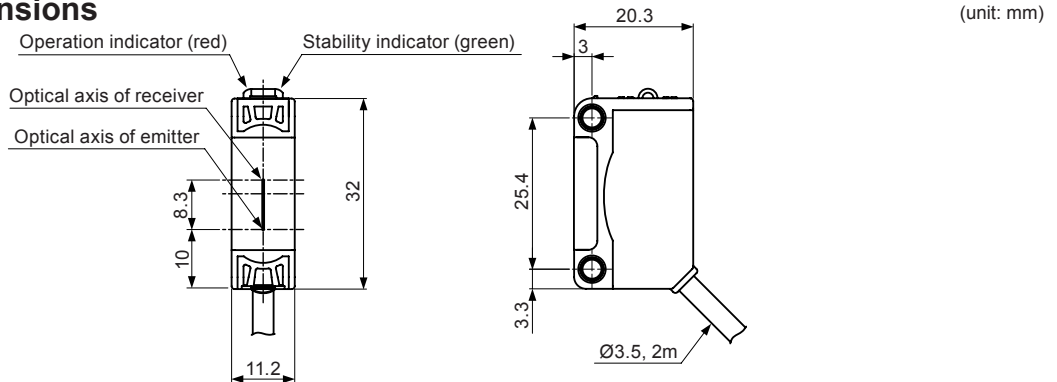

- (A) Photoelectric Sensors
- (B) Fiber Optic Sensors
- (C) Door/Area Sensors
- (D) Proximity Sensors
- (E) Pressure Sensors
- (F) Rotary Encoders
- (G) Connectors/ Connector Cables/ Sensor Distribution Boxes/Sockets
- (H) Temperature Controllers
- (I) SSRs / Power Controllers
- (J) Counters
- (K) Timers
- (L) Panel Meters
- (M) Tacho / Speed / Pulse Meters
- (N) Display Units
- (O) Sensor Controllers
- (P) Switching Mode Power Supplies
- (Q) Stepper Motors & Drivers & Controllers
- (R) Graphic/ Logic Panels
- (S) Field Network Devices
- (T) Software

BJP Series

●Bracket A

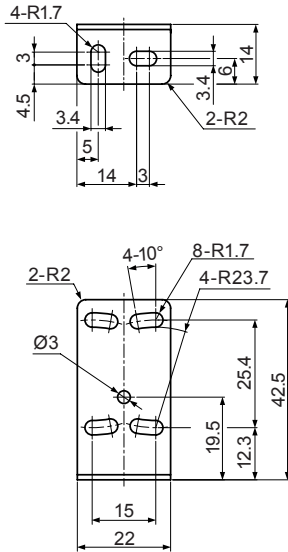

●Bracket B (BK-BJP-B, sold separately)

(unit: mm)

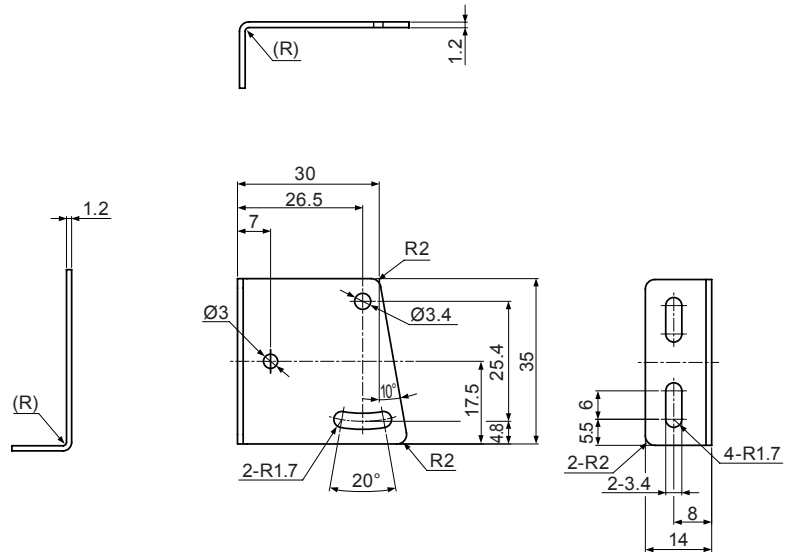

■ Operation Timing Diagram

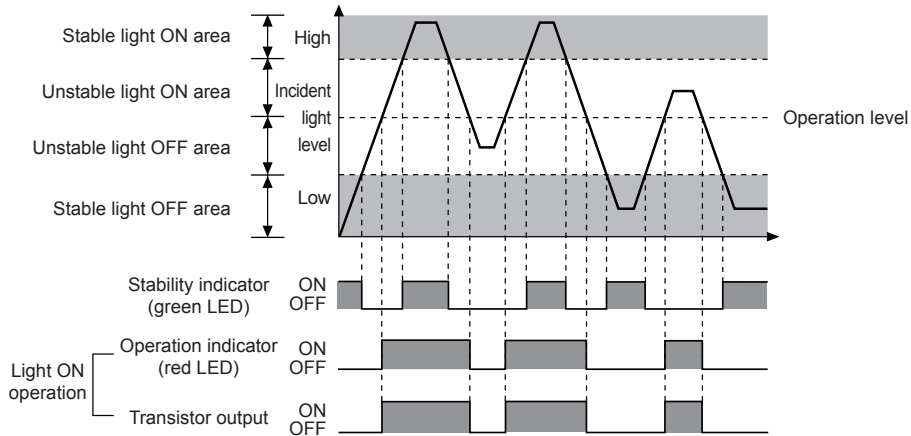

※The waveforms of 'Operation indicator' and 'Transistor output' are for Light ON operation.
The waveforms are reversed for Dark ON operation.

■ Installation and Adjustment

◎ For mounting

When using photoelectric sensors closely over three units, it may result in malfunction due to mutual interference.

When installing the product, tighten the screw with a tightening torque of 0.5N·m.

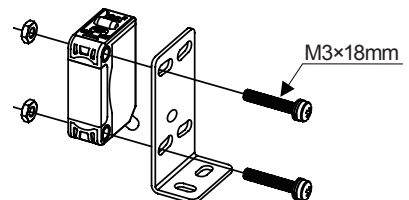

Photoelectric Sensor for PCB detection

- The sensing side of the unit and the surface of the target object should be parallel when installed.

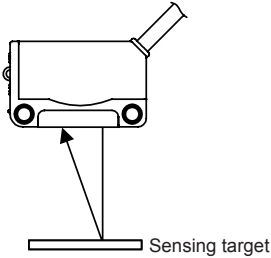

- If the sensing target has a glossy surface, mount the sensor at a 5 to 10° angle as shown in the figure. Check to see that there is no influence from background objects.

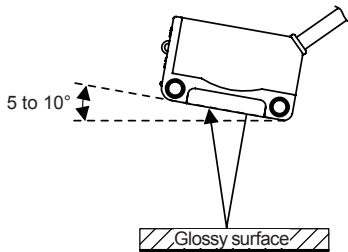

- If there is a reflective surface beneath the sensor, the reflected light may reflect off the surface of the reflective object. Make sure that the sensor is tilted upwards as shown in the figure, or install the sensor distant to the reflective surface.

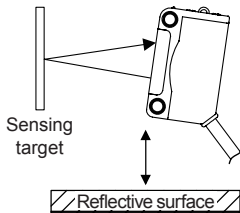

◎ Optical axis adjustment

- Place the sensing target. Move the sensor slightly in each direction and check the operation of the stability indicator. Fix the sensor at the center point.

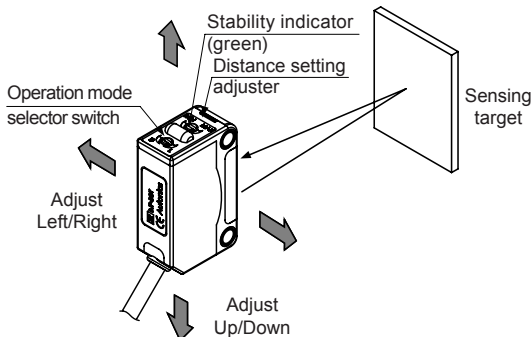

◎ Operation mode switching

Light ON		Turn the operation mode selection switch all the way to the right (towards L) to select Light ON operation.
Dark ON		Turn the operation mode selection switch all the way to the left (towards D) to select Dark ON operation.

◎ Distance setting

Order	Distance setting	Description
1		From Light ON status, turn the distance setting adjuster slowly to the right from MIN distance and check the position where operation indicator turns on (A).
2		From Dark ON status, turn the distance setting adjuster further right and check the position where the operation indicator turns on (B). Turn the adjuster left and check the position where the operation indicator turns off (C). ※If the operation indicator does not turn on at MAX distance, the maximum setting distance is set at position (C).
3		Set the adjuster at the center position between (A) and (C) for optimal sensitivity. Also, check if the stability indicator turns off with or without the sensing target. If it does not turn off, please review the operation mode again, as sensitivity may be unstable.

	Light ON status	Dark ON status
BGS reflective type		

※Set the distance setting within stable Light ON range for increased environmental (temperature, voltage, dust etc.) resistance after installation.

※Do not use excessive force when turning the operation selector or distance setting adjuster. It may cause product damage.

(A) Photoelectric Sensors

(B) Fiber Optic Sensors

(C) Door/Area Sensors

(D) Proximity Sensors

(E) Pressure Sensors

(F) Rotary Encoders

(G) Connectors/ Connector Cables/ Sensor Distribution Boxes/Sockets

(H) Temperature Controllers

(I) SSRs / Power Controllers

(J) Counters

(K) Timers

(L) Panel Meters

(M) Tacho / Speed / Pulse Meters

(N) Display Units

(O) Sensor Controllers

(P) Switching Mode Power Supplies

(Q) Stepper Motors & Drivers & Controllers

(R) Graphic/ Logic Panels

(S) Field Network Devices

(T) Software