

EB360.MC-C.TM8A.V4GC1.13120N

Magnetic multiturn encoder, magnetic rotor with threaded screw

Article number: 11266755

Overview

- Non contact absolute encoder / SSI
- Resolution up to 13 bit single- / 12 bit multiturn
- Precise magnetic sensing
- High resistance to shock and vibrations
- Cable 1 m, open cable end
- Magnetic rotor included in delivery (calibrated set)



Technical data

Technical data - electrical ratings

Voltage supply	4.5...30 VDC
Consumption typ.	60 mA (5 VDC, w/o load) 20 mA (24 VDC, w/o load)
Initializing time	≤ 170 ms after power on
Inputs	SSI clock: Linereceiver RS422 Zero setting input Counting direction
Interface	SSI
Function	Multiturn
Steps per revolution	8192 / 13 bit
Number of revolutions	4096 / 12 bit
Output stages	SSI data: Linedriver RS422
Absolute accuracy	±0.3 ° (+20 ±15 °C) ±0.5 ° (-40...+85 °C)
Sensing method	Magnetic
Code	Gray
Code sequence	CW: ascending values with clockwise sense of rotation (looking at flange)
Interference immunity	EN 61000-6-2
Emitted interference	EN 61000-6-4

Technical data - electrical ratings

Approval	UL approval / E217823 CE
----------	-----------------------------

Technical data - mechanical design

Size (flange)	ø36 mm
Magnet rotor	M8 x 8 mm, threaded screw
Protection EN 60529	IP 67 (sensor housing)
Operating speed	≤6000 rpm
Working distance	0.9 ±0.8 mm (axial) ≤ 0.3 mm (radial)
Material	Housing: PA10T / GF30 Cable sheath: PUR Magnet rotor: aluminium, anodised
Operating temperature	-40...+85 °C (see general information)
Relative humidity	95 %
Resistance	EN 60068-2-6 Vibration 30 g, 10-2000 Hz EN 60068-2-27 Shock 500 g, 1 ms
Weight approx.	100 g
Connection	Cable, length 1 m, open cable end

General information

Self-heating correlated to installation and ambient conditions as well as to electronics and supply voltage must be considered for precise thermal dimensioning. Operating the encoder close to the maximum limits requires measuring the real prevailing temperature at the encoder flange.

Terminal assignment

Cable	
Core color	Signals
white	0 V
brown	+Vs
green	Clock+
yellow	Clock-
grey	Data+
pink	Data-
blue	SET
red	DIR

Cable data: 4 x 2 x 0.14 mm², shielded, twisted in pairs

Terminal significance

SET	Zero setting. Input for zero setting at any position. The zero setting operation is triggered by a high pulse and has to be in line with the selected direction of rotation (DIR). Impulse duration >100 ms. Connect to 0 V after zero setting for maximum interference immunity.
DIR	Counting direction input. The input is standard on high. For maximum interference immunity connect to +Vs respectively 0 V depending on counting direction. CW HIGH - CCW LOW (Version with DATAVALID does not include the counting direction input).

Trigger level

Control inputs	Input circuit
Maximal	0...+Vs
Input level Low	<1 V
Input level High	>2.1 V

Applies to standard cable lengths up to 2 m, for longer cables the voltage drop must be taken into account.

Data transfer

Output signal

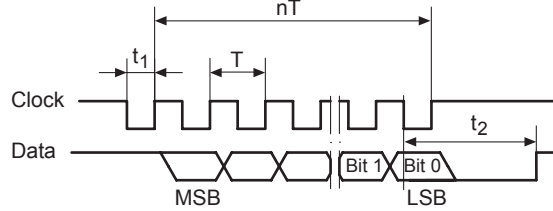

$T = 0.5 \dots 10 \mu\text{s}$	$t_1 = 0.25 \dots 5 \mu\text{s}$
$t_2 = 20 \pm 2 \mu\text{s}$	$f \text{ max.} = 2 \text{ MHz}$

Data acquisition time ta

Following timing of the SSI Masters is the requirement for a data refresh rate of typ. 2 μs . If this is not fulfilled the data refresh rate is <50 μs .
 $t_a < 5000 \mu\text{s}$
 $t_a \text{ jitter} < \pm 2 \mu\text{s}$

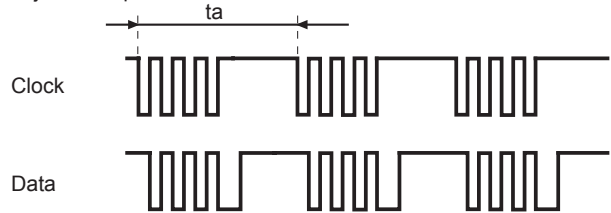

Angular misalignment

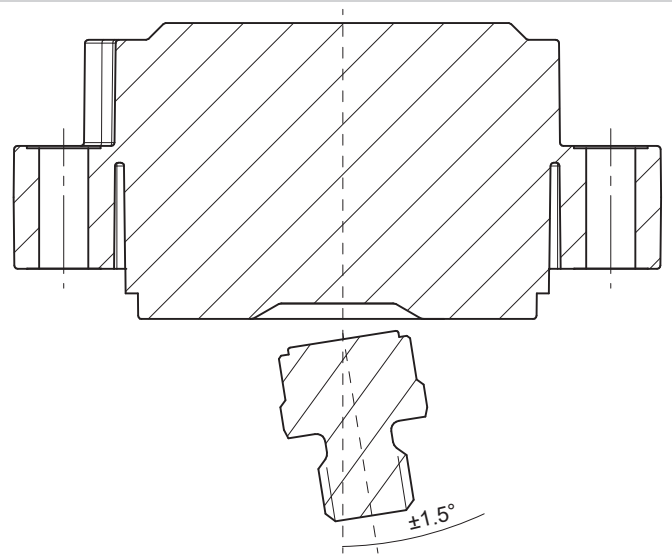

Working distance

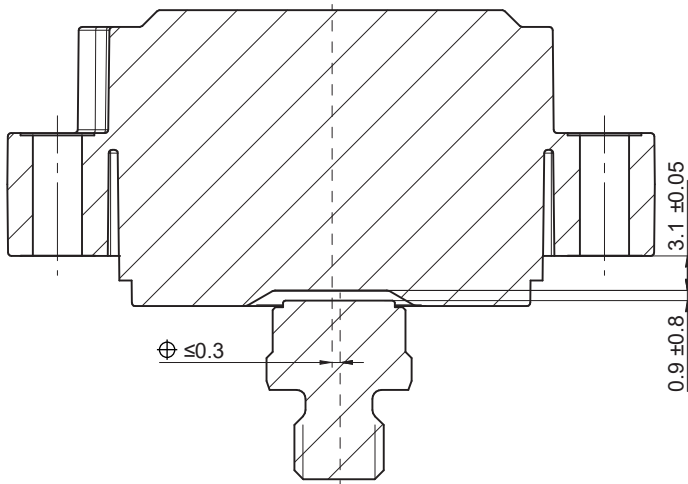

The ideal working distance of the magnet related to the encoder is at an eccentricity of 0 mm and an axial distance of 0.9 mm. Deviation affects the accuracy as shown in following diagram.

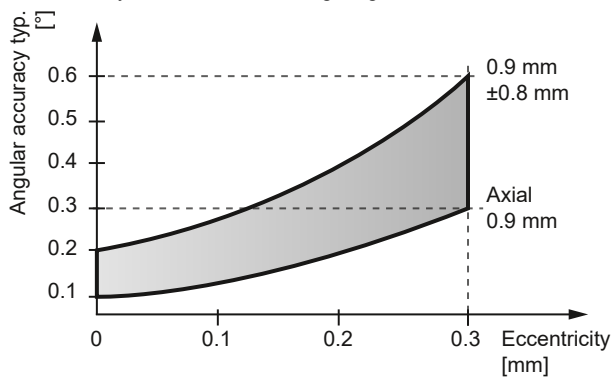

Mounting recommendation

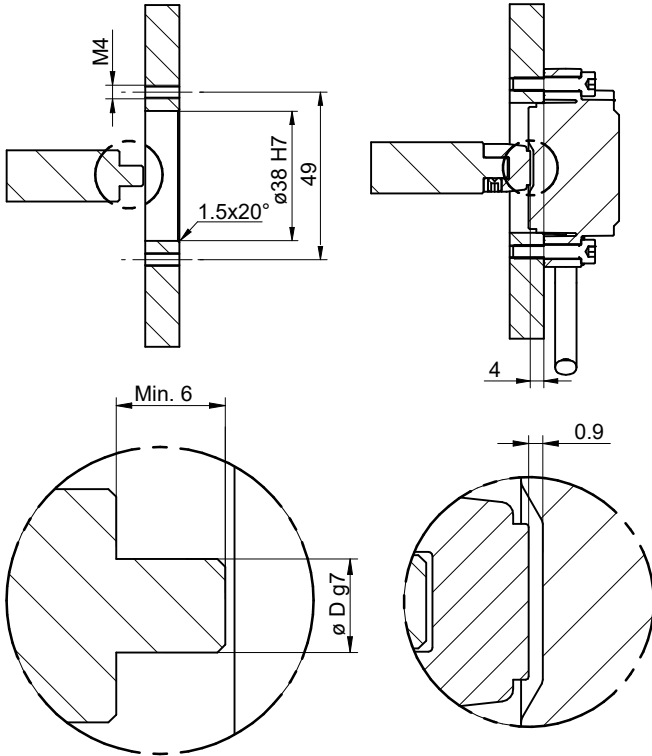

Screw mount