

ES 90

Electronic speed switch

1 adjustable switching speed

Overview

- Electronic speed monitoring
- Circuit breaker with one selectable threshold speed
- Relay output with isolated changeover contact



Technical data

Technical data - electrical ratings

Switching accuracy	± 4 % (≤1500 rpm) ± 2 % (>1500 rpm)
Switching hysteresis	= 30 % of switching speed
Switching outputs	1 output, speed control
Output switching capacity	≤6 A / 250 VAC ≤1 A / 48 VDC (EAC: <50 VAC / 75 VDC)
Minimum switching current	100 mA
Switching delay time	≤40 ms
Interference immunity	EN 61000-6-2
Emitted interference	EN 61000-6-3
Approval	CE

Technical data - mechanical design

Size (flange)	ø115 mm
---------------	---------

Technical data - mechanical design

Shaft type	ø11 mm solid shaft
Flange	EURO flange B10
Protection EN 60529	IP 55
Speed (n)	≤6000 rpm
Range of switching speed (ns)	650...6000 rpm
Operating torque	≤2 Ncm
Rotor moment of inertia	0.125 kgcm ²
Admitted shaft load	≤150 N axial ≤250 N radial
Operating temperature	-20...+85 °C
Weight approx.	1.3 kg
Connection	Terminal box
Material	Housing: aluminium die-cast Shaft: stainless steel

Optional

- As integrated speed switch type ESL for combination with encoders and/or tachogenerators

ES 90

Electronic speed switch

1 adjustable switching speed

Terminal assignment

View A (see dimension)

Connecting terminal

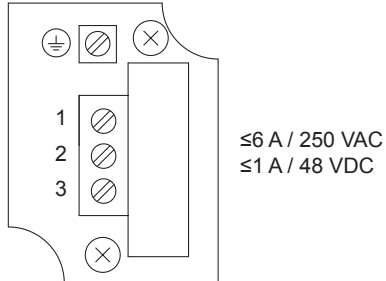

Block circuit diagram

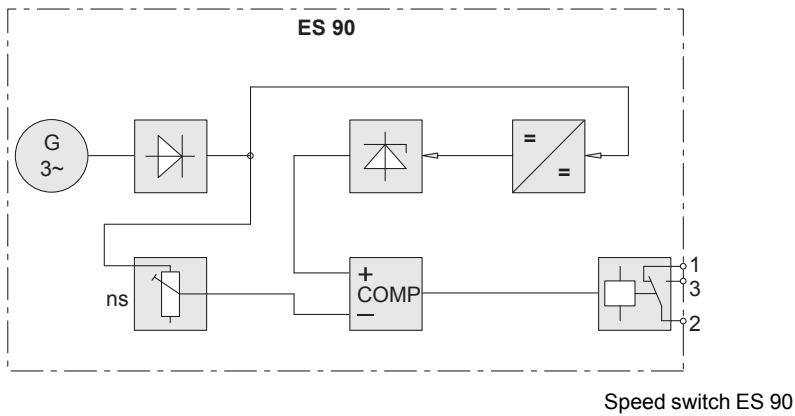

Switching characteristics

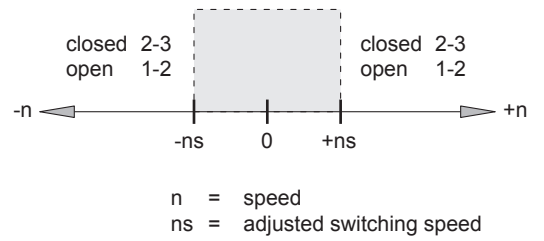

ES 90

Electronic speed switch

1 adjustable switching speed

Dimensions

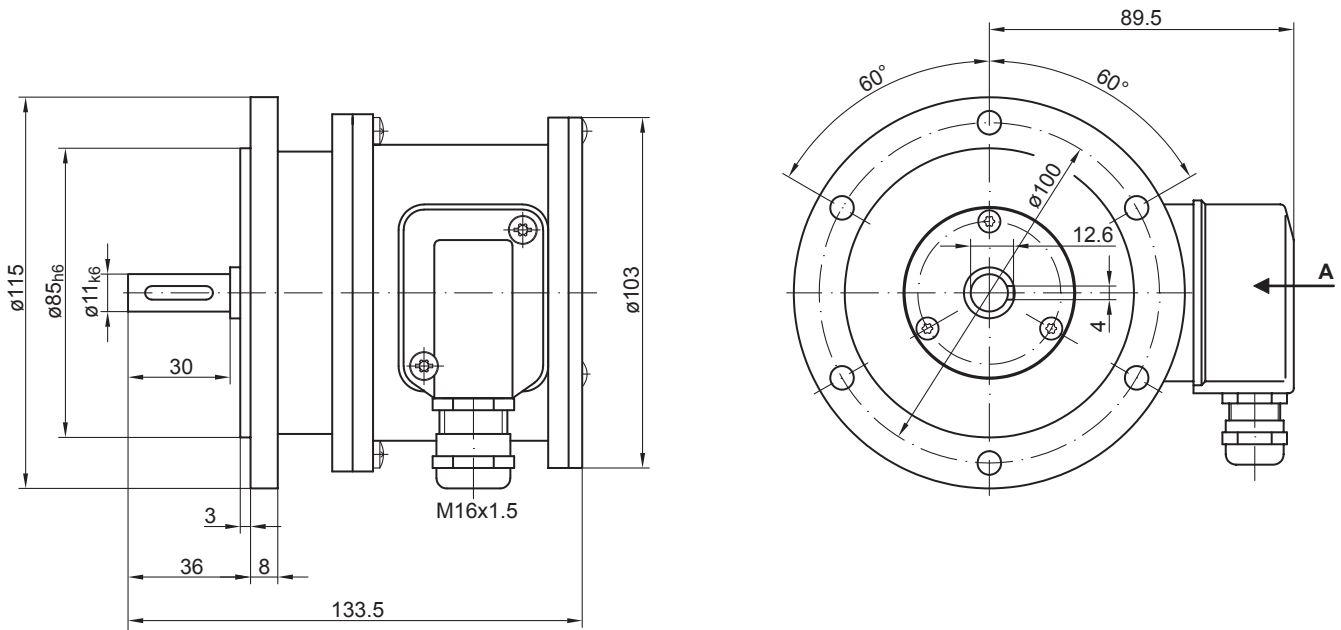

ES 90

Electronic speed switch

1 adjustable switching speed

Ordering reference

Product	ES90	...
Speed switch	ES90	
Switching speed (ns)		
650...6000 rpm ⁽¹⁾		...

(1) Please specify the exact switching speed in addition to the part number (factory setting).

Accessories

Mounting accessories

- Spring disk coupling K 35 (shaft \varnothing 6...12 mm)
- Spring disk coupling K 50 (shaft \varnothing 11...16 mm)
- Spring disk coupling K 60 (shaft \varnothing 11...22 mm)