

HS35F

Insulated through hollow shaft $\varnothing 0.375 \dots 1$ inch
1024...80000 pulses per revolution

Overview

- Robust industrial encoder up to IP 67 protection
- Shock resistant up to 200 g's
- Insulating insert to prevent high shaft currents from damaging bearings
- Wide range voltage supply 4.75...30 VDC
- Precision ≤ 60 arc-seconds for perfect process control
- Max. 80000 pulses per revolution



Technical data

Technical data - electrical ratings

Voltage supply	4.75...30 VDC
Reverse polarity protection	Yes
Consumption w/o load	≤ 40 mA (24 VDC) ≤ 130 mA (4.75 VDC) + output load, max. 250 mA
Pulses per revolution	1024 ... 80000
Accuracy	≤ 60 arc-seconds
Sensing method	Optical
Output frequency	≤ 300 kHz (TTL) ≤ 160 kHz (HTL)
Output signals	A, B, Z A, B, Z + complement, $\frac{1}{2}$ cycle index gated with negative B channel
Output stages	Linedriver (TTL, 7272) $V_{out} = 5$ V, short-circuit proof Push-pull (HTL, 7272) $V_{out} = V_{in}$, short-circuit proof
Interference immunity	EN 61000-6-2
Emitted interference	EN 61000-6-3
Approval	UL approval / E240061 RoHS compliant EU guideline 2011/65/EC CE

Technical data - mechanical design

Size (flange)	$\varnothing 3.15$ " ($\varnothing 80$ mm)
Shaft type	$\varnothing 0.375 \dots 1$ " ($\varnothing 9.525 \dots 25.4$ mm) (through hollow shaft isolated)

Technical data - mechanical design

Bore runout	0.0016" (0.04 mm) TIR max.
Admitted misalignment	0.004" (0.1016 mm) radial TIR (end of shaft) 0.01" (0.254 mm) axial
Protection EN 60529	IP 54 IP 65 IP 67
Operating speed	≤ 5000 rpm (see temperature diagram)
Bearing	52100 SAE high carbon steel (ABEC 5)
Starting torque	≤ 3 in-oz (77 °F, IP 65) ≤ 0.02 Nm (+25 °C, IP 65)
Rotor moment of inertia	2.3 oz-in ² (420 gcm ²)
Service life	Bearing: typ. 13 billion rev. (89000 h/2500 rpm)
Material	Housing: aluminium, powder-coated Shaft: stainless steel
Operating temperature	-40...+212 °F (-40...+100 °C), (fixed cable): see temperature diagram
Relative humidity	98 % non-condensing
Resistance	EN 60068-2-6 Vibration 20 g, 60-2000 Hz EN 60068-2-27 Shock 200 g, 6 ms
Connection	MIL-connector, 7-pin MIL-connector, 10-pin Cable (AWG26 wire)
Weight approx.	23 oz. 660 g

HS35F

Insulated through hollow shaft $\varnothing 0.375 \dots 1$ inch
1024 \dots 80000 pulses per revolution

Terminal assignment

MI07: MIL-connector, 7-pin

Connector	Assignment
Pin A	Track A
Pin B	Track B
Pin C	Track Z
Pin D	+Vs
Pin E	-
Pin F	0 V
Pin G	Housing

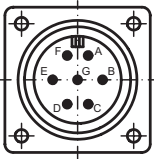

MI10: MIL-connector, 10-pin

Connector	Assignment
Pin A	Track A
Pin B	Track B
Pin C	Track Z
Pin D	+Vs
Pin E	-
Pin F	0 V
Pin G	Housing
Pin H	Track A complement
Pin I	Track B complement
Pin J	Track Z complement

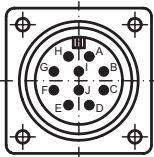

Cable gland (AWG26 wire)

Core colour	Assignment
green	Track A
grey	Track B
pink	Track Z
red	+Vs
blue	0 V
transparent	Shield/Housing
brown	Track A complement
black	Track B complement
white	Track Z complement

Output signals

Phasing = B: Counterclockwise rotation (standard) from clamping end.
Phasing = D: Clockwise rotation (option) from clamping end.

ABZ-Output signals

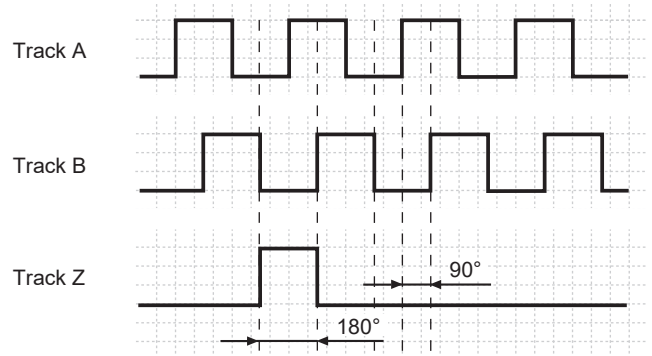

ABZC-Output signals

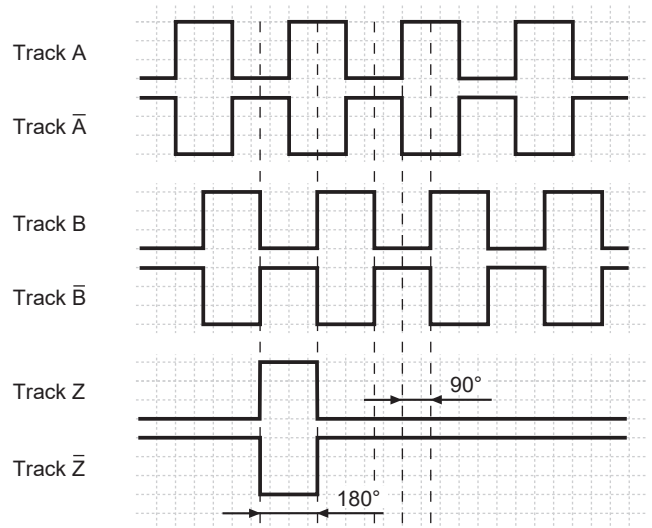

Trigger level

Outputs	Linedriver (TTL, 7272)
Output level High	≥ 2.4 V
Output level Low	≤ 0.5 V
Load	≤ 40 mA

Outputs	Push pull (HTL, 7272)
Output level High	$\geq U_B - 3$ V
Output level Low	≤ 1.5 V
Load	≤ 40 mA

HS35F

Insulated through hollow shaft $\varnothing 0.375 \dots 1$ inch
1024...80000 pulses per revolution

Temperature diagram

ambient temperature + self heating
 \leq max. operating temperature +212 °F (+100 °C)

self-heating per 1000 rpm:

IP 54: +9 °F (+5 °C)
IP 65: +18 °F (+10 °C)
IP 67: +27 °F (+15 °C)

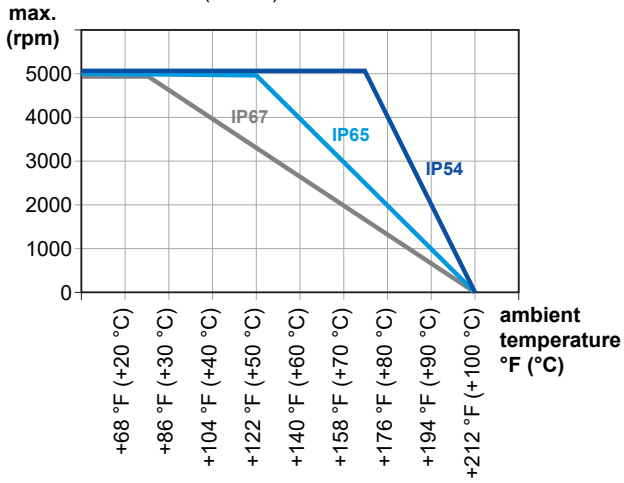

HS35F

Insulated through hollow shaft $\varnothing 0.375...1$ inch
1024...80000 pulses per revolution

Dimensions

HS35F

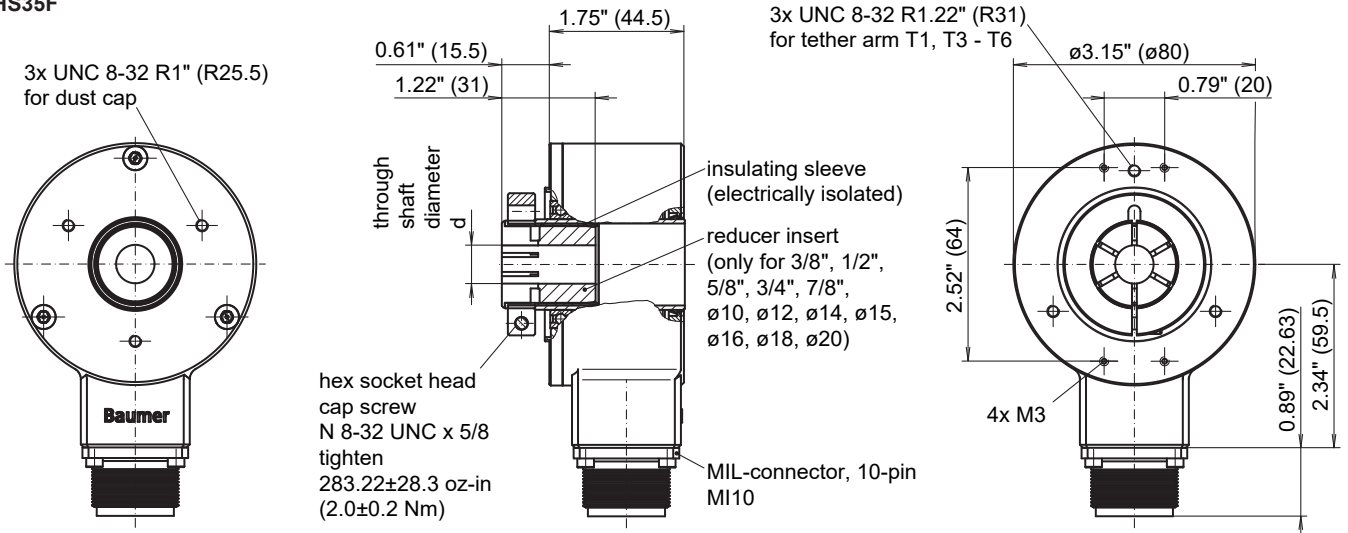

ø nominal dimension		tolerance					
		hollow shaft encoder			recommended customer shaft		
inch (in ")	metric (in mm)		inch (in 1/1000")	metric (in µm)		inch (in 1/1000")	metric (in µm)
1.000"	25.400	G7	+1.10 +0.28	+28 +7	h6	0 -0.51	0 -13
0.875"	22.225	G7	+1.10 +0.28	+28 +7	h6	0 -0.51	0 -13
0.750"	19.050	G7	+1.10 +0.28	+28 +7	h6	0 -0.51	0 -13
0.625"	15.875	G7	+0.94 +0.24	+24 +6	h6	0 -0.43	0 -11
0.500"	12.700	G7	+0.94 +0.24	+24 +6	h6	0 -0.43	0 -11
0.375"	9.525	G7	+0.79 +0.20	+20 +5	h6	0 -0.35	0 -9
0.787"	20	H8	+1.30 0	+33 0	g6	-0.28 -0.79	-7 -20
0.709"	18	H8	+1.06 0	+27 0	g6	-0.24 -0.67	-6 -17
0.630"	16	H8	+1.06 0	+27 0	g6	-0.24 -0.67	-6 -17
0.591"	15	H8	+1.06 0	+27 0	g6	-0.24 -0.67	-6 -17
0.551"	14	H8	+1.06 0	+27 0	g6	-0.24 -0.67	-6 -17
0.472"	12	H8	+1.06 0	+27 0	g6	-0.24 -0.67	-6 -17
0.394"	10	H8	+1.06 0	+27 0	g6	-0.20 -0.55	-5 -14

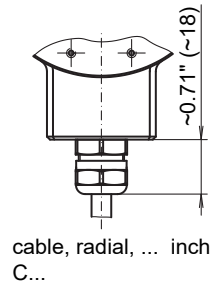
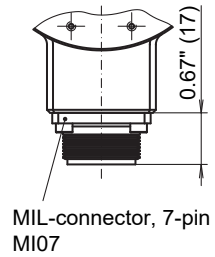

HS35F

Insulated through hollow shaft $\varnothing 0.375 \dots 1$ inch
1024...80000 pulses per revolution

Dimensions

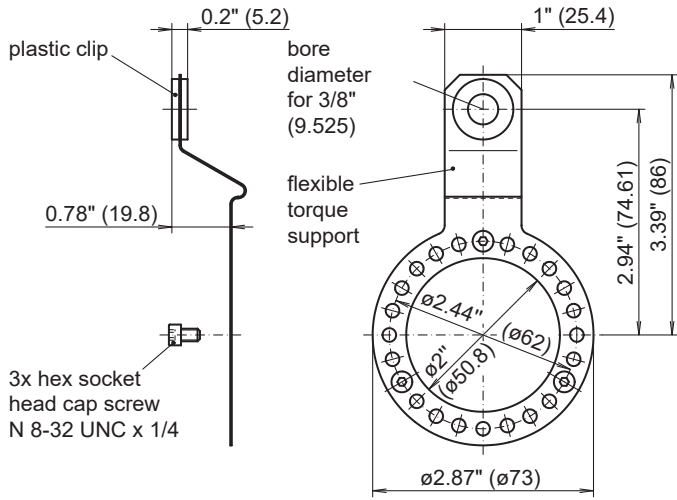

Tether arm T1

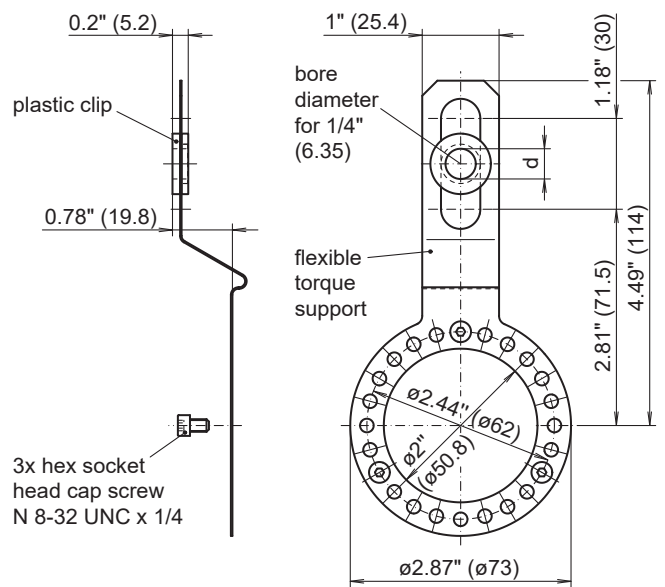

Tether arm T3

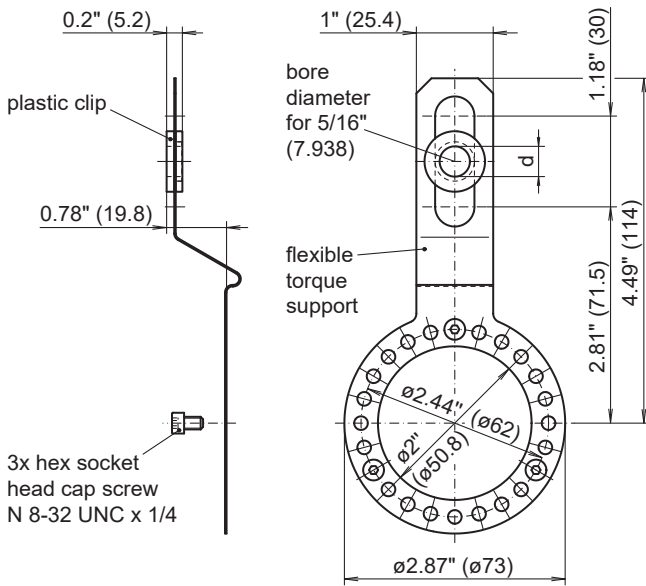

Tether arm T4

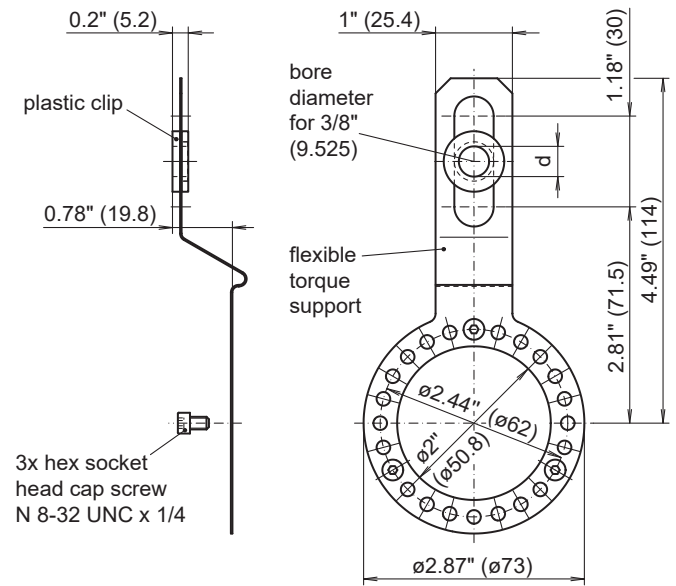

Tether arm T5

3x hex socket
head cap screw
N 8-32 UNC x 1/4

3x hex socket
head cap screw
N 8-32 UNC x 1/4

3x hex socket
head cap screw
N 8-32 UNC x 1/4

3x hex socket
head cap screw
N 8-32 UNC x 1/4

HS35F

Insulated through hollow shaft $\varnothing 0.375 \dots 1$ inch
1024...80000 pulses per revolution

Dimensions

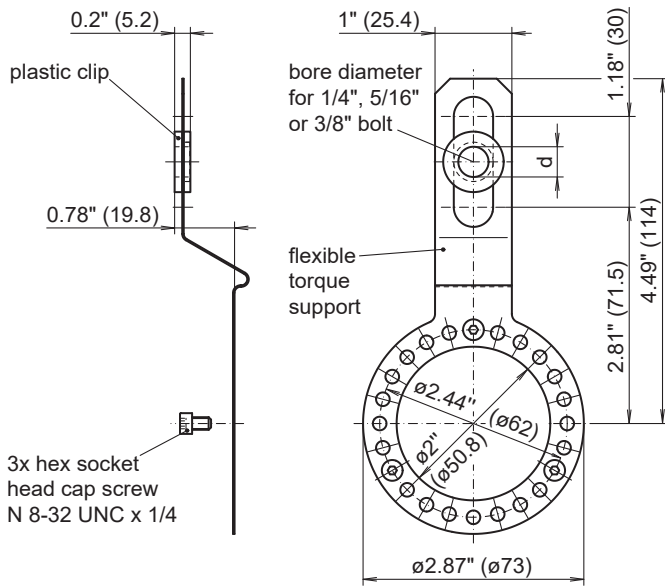

Tether arm T6

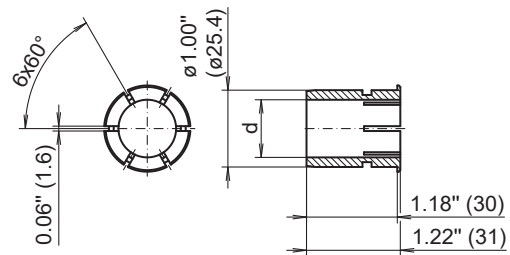

ø nominal dimension		tolerance		
inch (in ")	metric (in mm)		inch (in 1/1000")	metric (in µm)
0.875"	22.225	G7	+1.10 +0.28	+28 +7
0.750"	19.050	G7	+1.10 +0.28	+28 +7
0.625"	15.875	G7	+0.94 +0.24	+24 +6
0.500"	12.700	G7	+0.94 +0.24	+24 +6
0.375"	9.525	G7	+0.79 +0.20	+20 +5
0.787"	20	H8	+1.30 0	+33 0
0.709"	18	H8	+1.06 0	+27 0
0.630"	16	H8	+1.06 0	+27 0
0.591"	15	H8	+1.06 0	+27 0
0.551"	14	H8	+1.06 0	+27 0
0.472"	12	H8	+1.06 0	+27 0
0.394"	10	H8	+1.06 0	+27 0

Reducer inserts

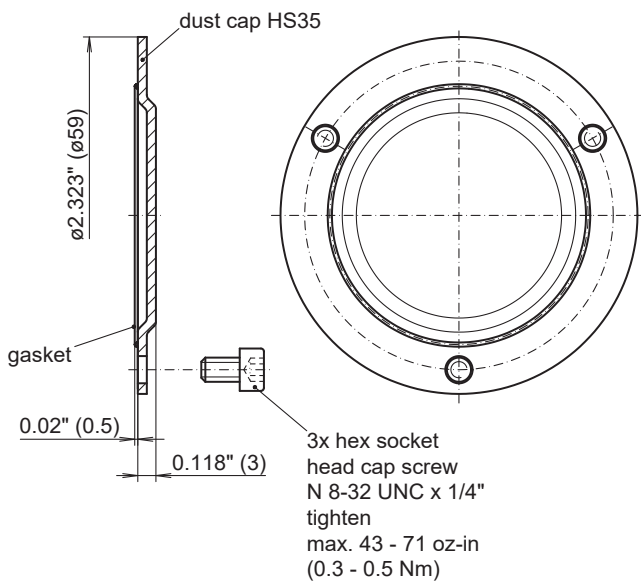

Dust cap HS35

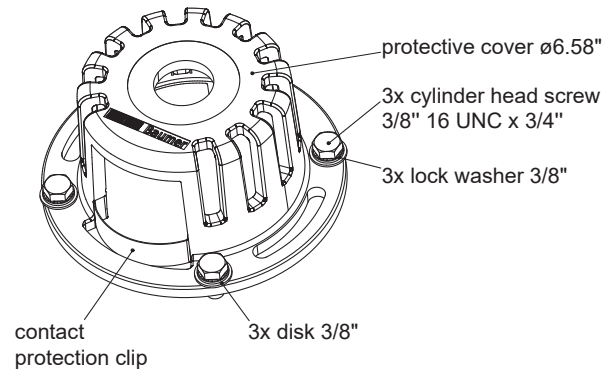

Protective cage HS35

HS35F

Insulated through hollow shaft $\varnothing 0.375 \dots 1$ inch
1024 \dots 80000 pulses per revolution

Dimensions

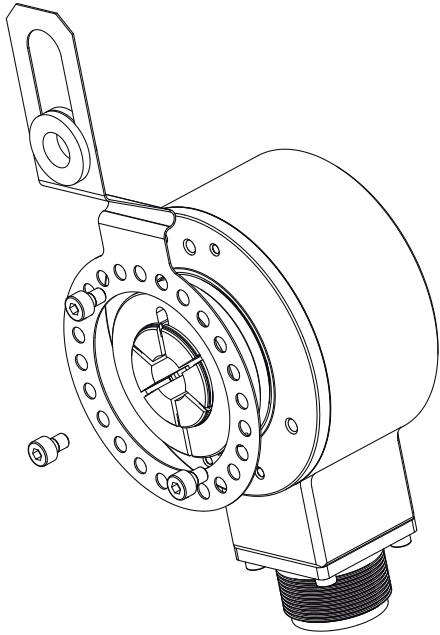

Example fitting tether arm

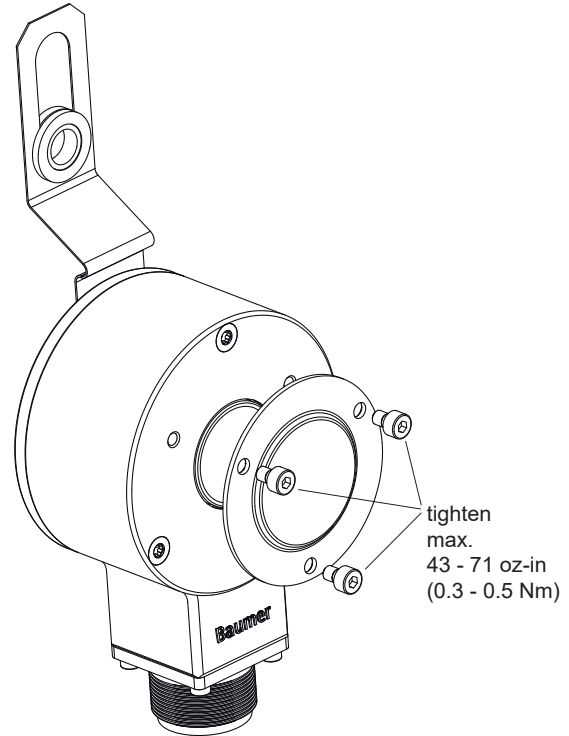

Example fitting dust cap

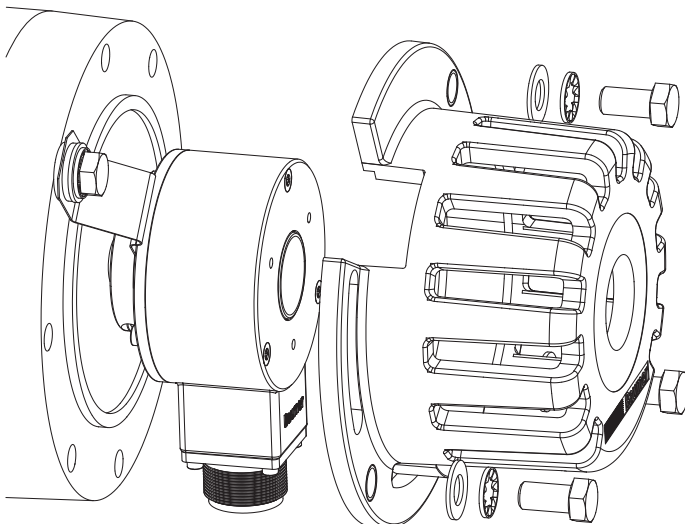

Example fitting protective cover

HS35F

 Insulated through hollow shaft $\varnothing 0.375 \dots 1$ inch
 1024...80000 pulses per revolution

Ordering reference

	HS35F	#####	###	###	#####	#	E	###	#	###
Product	HS35F									
Pulse number										
1024		01024								
2000		02000								
2048		02048								
2500		02500								
3072		03072								
3600		03600								
4096		04096								
5000		05000								
8192 ⁽¹⁾		08192								
10000 ⁽¹⁾		10000								
15000 ⁽¹⁾		15000								
16384 ⁽¹⁾		16384								
20000 ⁽¹⁾		20000								
25000 ⁽¹⁾		25000								
32768 ⁽¹⁾		32768								
40000 ⁽¹⁾		40000								
80000 ⁽¹⁾		80000								
Voltage supply										
UB= 4,75...30 VDC, Vout = Vin (7272) / HTL-signals										H
UB= 4.75...30 VDC, Vout = 5 VDC (7272) / TTL-signals										T
Output signal										
A, B, Z										ABZ_
A, B, Z + complements										ABZC
Connection										
MIL-connector, 7-pin										MI07
MIL-connector, 10-pin										MI10
Cable radial, 12 (305 mm)										C012
Cable radial, 18 (457 mm)										C018
Cable radial, 24 (610 mm) ⁽²⁾										C024
Phasing										
Standard phasing, CCW rotation, A leads B										B
Phasing option, CW rotation, A leads B										D
Operating temperature										
-40...+212 °F (-40...+100 °C)										E

HS35F

 Insulated through hollow shaft $\varnothing 0.375 \dots 1$ inch
 1024...80000 pulses per revolution

Ordering reference

	HS35F	#####	###	####	#####	#	E	###	#	###
Through hollow shaft										
$\varnothing 0.375$ ($\varnothing 9.525$ mm) isolated, clamping ring A-side										037
$\varnothing 0.500$ ($\varnothing 12.7$ mm) isolated, clamping ring A-side										050
$\varnothing 0.625$ ($\varnothing 15.88$ mm) isolated, clamping ring A-side										062
$\varnothing 0.750$ ($\varnothing 19.05$ mm) isolated, clamping ring A-side										075
$\varnothing 0.875$ ($\varnothing 22.23$ mm) isolated, clamping ring A-side										087
$\varnothing 1.000$ ($\varnothing 25.4$ mm) isolated, clamping ring A-side										100
$\varnothing 10$ mm isolated, clamping ring A-side										M10
$\varnothing 12$ mm isolated, clamping ring A-side										M12
$\varnothing 14$ mm isolated, clamping ring A-side										M14
$\varnothing 15$ mm isolated, clamping ring A-side										M15
$\varnothing 16$ mm isolated, clamping ring A-side										M16
$\varnothing 18$ mm isolated, clamping ring A-side										M18
$\varnothing 20$ mm isolated, clamping ring A-side										M20
Protection class										
IP 54										4
IP 65										5
IP 67 ⁽³⁾										7
Mounting kit										
Tether arm T1, fixed length, for bolt 3/8										T1
Tether arm T3, adjustable length, for bolt 1/4										T3
Tether arm T4, adjustable length, for bolt 5/16										T4
Tether arm T5, adjustable length, for bolt 3/8										T5
Tether arm T6, adjustable, kit, bolts 1/4, 5/16, 3/8										T6

- (1) Pulse numbers are interpolated.
 (2) Other cable lengths on request.
 (3) Dust cap included

HS35F

Insulated through hollow shaft $\varnothing 0.375 \dots 1$ inch
 1024...80000 pulses per revolution

Accessories

Mounting accessories

11076339	Torque arm T1, fixed length, for bolt 3/8" with plastic clip and screws
11075692	Torque arm T3, adjustable length, for bolt 1/4" with plastic clip and screws
11075690	Torque arm T4, adjustable length, for bolt 5/16" with plastic clip and screws
11071506	Torque arm T5, adjustable length, for bolt 3/8" with plastic clip and screws
11167978	Torque arm T6, adjustable length, kit for bolts 1/4", 5/16" and 3/8" with plastic clip and screws
11084462	Reducer insert HS35 $\varnothing 0.375$ " ($\varnothing 9.525$ mm)
11078636	Reducer insert HS35 $\varnothing 0.50$ " ($\varnothing 12.7$ mm)
11080114	Reducer insert HS35 $\varnothing 0.625$ " ($\varnothing 15.875$ mm)
11078639	Reducer insert HS35 $\varnothing 0.75$ " ($\varnothing 19.05$ mm)
11078654	Reducer insert HS35 $\varnothing 0.87$ " ($\varnothing 22.225$ mm)
11087744	Reducer insert HS35 $\varnothing 10$ mm
11087745	Reducer insert HS35 $\varnothing 12$ mm
11087746	Reducer insert HS35 $\varnothing 14$ mm
11148651	Reducer insert HS35 $\varnothing 15$ mm
11087747	Reducer insert HS35 $\varnothing 16$ mm
11087748	Reducer insert HS35 $\varnothing 18$ mm
11087750	Reducer insert HS35 $\varnothing 20$ mm
11075459	Dust cap HS35
11080884	Protective cage HS35

Connectors and cables

11128642	NAC 25E 7-pin Mil Spec Mating Connector
11078440	CNAC 25E 7-pin Mil Spec Mating Connector + cable L=10 ft (3.05 m)
11078442	CNAC 25E 7-pin Mil Spec Mating Connector + cable L=20 ft (6.10 m)
11078446	CNAC 25E 7-pin Mil Spec Mating Connector + cable L=30 ft (9.15 m)
11126235	NAC 29H 10-pin Mil Spec Mating Connector
11078307	CNAC 29H 10-pin Mil Spec Mating Connector + cable L=10 ft (3.05 m)
11078427	CNAC 29H 10-pin Mil Spec Mating Connector + cable L=20 ft (6.10 m)
11078428	CNAC 29H 10-pin Mil Spec Mating Connector + cable L=30 ft (9.15 m)