

# Product datasheet

Specifications



## Variable speed drive, Altivar Solar, 1.1kW, 380 to 500V, 3 phases, compact

ATV320U11N4C412

### Main

Range of product	Altivar Solar
Product or component type	Variable speed drive
Product specific application	Pumping applications
Variant	Standard version
Format of the drive	Compact
mounting mode	Wall mount
Communication port protocol	Modbus serial CANopen
Option card	Communication module, Ethernet IP/Modbus TCP
[Us] rated supply voltage	380...500 V - 15...10 %
Nominal output current	3.0 A
Motor power kW	1.1 kW for heavy duty
EMC filter	Class C2 EMC filter integrated
IP degree of protection	IP20

### Complementary

Discrete input number	7
Discrete input type	STO safe torque off, 24 V DC, impedance: 1.5 kOhm DI1...DI6 logic inputs, 24 V DC (30 V) DI5 programmable as pulse input: 0...30 kHz, 24 V DC (30 V)
Discrete input logic	Positive logic (source) Negative logic (sink)
Discrete output number	3
Discrete output type	Open collector DQ+ 0...1 kHz 30 V DC 100 mA Open collector DQ- 0...1 kHz 30 V DC 100 mA
Analogue input number	3
Analogue input type	AI1 voltage: 0...10 V DC, impedance: 30 kOhm, resolution 10 bits AI2 bipolar differential voltage: +/- 10 V DC, impedance: 30 kOhm, resolution 10 bits AI3 current: 0...20 mA (or 4-20 mA, x-20 mA, 20-x mA or other patterns by configuration), impedance: 250 Ohm, resolution 10 bits
Analogue output number	1
Analogue output type	Software-configurable current AQ1: 0...20 mA impedance 800 Ohm, resolution 10 bits Software-configurable voltage AQ1: 0...10 V DC impedance 470 Ohm, resolution 10 bits
Relay output number	2

<b>Relay output type</b>	Configurable relay logic R1A 1 NO electrical durability 100000 cycles Configurable relay logic R1B 1 NC electrical durability 100000 cycles Configurable relay logic R1C Configurable relay logic R2A 1 NO electrical durability 100000 cycles Configurable relay logic R2C
<b>Maximum switching current</b>	Relay output R1A, R1B, R1C on resistive load, cos phi = 1: 3 A at 250 V AC Relay output R1A, R1B, R1C on resistive load, cos phi = 1: 3 A at 30 V DC Relay output R1A, R1B, R1C, R2A, R2C on inductive load, cos phi = 0.4 and L/R = 7 ms: 2 A at 250 V AC Relay output R1A, R1B, R1C, R2A, R2C on inductive load, cos phi = 0.4 and L/R = 7 ms: 2 A at 30 V DC Relay output R2A, R2C on resistive load, cos phi = 1: 5 A at 250 V AC Relay output R2A, R2C on resistive load, cos phi = 1: 5 A at 30 V DC
<b>Minimum switching current</b>	Relay output R1A, R1B, R1C, R2A, R2C: 5 mA at 24 V DC
<b>Method of access</b>	Slave CANopen
<b>Number of addresses</b>	1...247 1...127
<b>Data format</b>	8 bits, configurable odd, even or no parity
<b>Type of polarization</b>	No impedance
<b>4 quadrant operation possible</b>	True
<b>Asynchronous motor control profile</b>	Voltage/frequency ratio, 5 points Flux vector control without sensor, standard Voltage/frequency ratio - Energy Saving, quadratic U/f Flux vector control without sensor - Energy Saving Voltage/frequency ratio, 2 points
<b>Synchronous motor control profile</b>	Vector control without sensor
<b>Transient overtorque</b>	170...200 % of nominal motor torque
<b>Maximum output frequency</b>	0.599 kHz
<b>Acceleration and deceleration ramps</b>	Linear U S CUS Ramp switching Acceleration/deceleration ramp adaptation Acceleration/deceleration automatic stop with DC injection Automatic adaptation of ramp if braking capacity exceeded, by using resistor Linear adjustable separately from 0.01 to 6000 s
<b>Motor slip compensation</b>	Automatic whatever the load Adjustable 0...300 % Not available in voltage/frequency ratio (2 or 5 points)
<b>Switching frequency</b>	2...16 kHz adjustable 4...16 kHz with derating factor
<b>Nominal switching frequency</b>	4 kHz
<b>Braking to standstill</b>	By DC injection
<b>Brake chopper integrated</b>	True
<b>Line current</b>	5.0 A at 380 V (heavy duty) 3.8 A at 500 V (heavy duty)
<b>Maximum input current</b>	5.0 A
<b>Maximum output voltage</b>	500 V
<b>Apparent power</b>	3.3 kVA at 500 V (heavy duty)
<b>Maximum transient current</b>	4.5 A during 60 s
<b>Short-circuit protection</b>	thermal protection
<b>Network frequency</b>	50...60 Hz
<b>Relative symmetric network frequency tolerance</b>	5 %

Prospective line I <sub>sc</sub>	5 kA
Base load current at high overload	22.0 A
Power dissipation in W	Fan: 40 W at 380 V, switching frequency 4 kHz
Electrical connection	Screw terminal, clamping capacity: 0.5...1.5 mm <sup>2</sup> for analog input Screw terminal for analog output Screw terminal
With safety function Safely Limited Speed (SLS)	True
With safety function Safe brake management (SBC/SBT)	False
With safety function Safe Operating Stop (SOS)	False
With safety function Safe Position (SP)	False
With safety function Safe programmable logic	False
With safety function Safe Speed Monitor (SSM)	False
With safety function Safe Stop 1 (SS1)	True
With sft fct Safe Stop 2 (SS2)	False
With safety function Safe torque off (STO)	True
With safety function Safely Limited Position (SLP)	False
With safety function Safe Direction (SDI)	False
Protection type	Input phase breaks: drive Overcurrent between output phases and earth: drive Overheating protection: drive Short-circuit between motor phases: drive Thermal protection: drive
Width	105.0 mm
Height	142.0 mm
Depth	158.0 mm
Net weight	1.3 kg
Power factor	0.482 at 380 V
Braking torque	170 % with braking resistor
Local signalling	1 LED (red) for drive fault 1 LED (red) for CANopen error 1 LED (green) for CANopen run

## Environment

Operating altitude	1000...2000 m with current derating 1 % per 100 m <= 1000 m without derating
Operating position	Vertical +/- 10 degree
product certifications	CE UR UKCA RCM
marking	CE UR UKCA RCM
Standards	IEC 61800-5-1
Assembly style	With heat sink

<b>Electromagnetic compatibility</b>	Electrostatic discharge immunity test level 3 conforming to IEC 61000-4-2 Radiated radio-frequency electromagnetic field immunity test level 3 conforming to IEC 61000-4-3 Electrical fast transient/burst immunity test level 4 conforming to IEC 61000-4-4 1.2/50 $\mu$ s - 8/20 $\mu$ s surge immunity test level 3 conforming to IEC 61000-4-5 Conducted radio-frequency immunity test level 3 conforming to IEC 61000-4-6 Voltage dips and interruptions immunity test conforming to IEC 61000-4-11
<b>Environmental class (during operation)</b>	Class 3C3 according to IEC 60721-3-3 Class 3S2 according to IEC 60721-3-3
<b>Maximum acceleration under shock impact (during operation)</b>	150 m/s <sup>2</sup> at 11 ms
<b>Maximum acceleration under vibrational stress (during operation)</b>	10 m/s <sup>2</sup> at 13...200 Hz
<b>Maximum deflection under vibratory load (during operation)</b>	1.5 mm at 2...13 Hz
<b>Permitted relative humidity (during operation)</b>	Class 3K5 according to EN 60721-3
<b>Volume of cooling air</b>	18.0 m <sup>3</sup> /h
<b>Overvoltage category</b>	II
<b>Regulation loop</b>	Adjustable PID regulator
<b>Speed accuracy</b>	+/- 10 % of nominal slip 0.2 Tn to Tn
<b>Noise level</b>	51 dB
<b>Pollution degree</b>	2
<b>Ambient air transport temperature</b>	-25...70 °C
<b>Ambient air temperature for operation</b>	-10...50 °C without derating 50...60 °C with derating factor
<b>Ambient air temperature for storage</b>	-25...70 °C

## Packing Units

<b>Unit Type of Package 1</b>	PCE
<b>Number of Units in Package 1</b>	1
<b>Package 1 Height</b>	18 cm
<b>Package 1 Width</b>	18.5 cm
<b>Package 1 Length</b>	18.5 cm
<b>Package 1 Weight</b>	1.696 kg
<b>Unit Type of Package 2</b>	S06
<b>Number of Units in Package 2</b>	30
<b>Package 2 Height</b>	75 cm
<b>Package 2 Width</b>	60 cm
<b>Package 2 Length</b>	80 cm
<b>Package 2 Weight</b>	63.88 kg

## Sustainability

**Green Premium™ label** is Schneider Electric's commitment to delivering products with best-in-class environmental performance. Green Premium promises compliance with the latest regulations, transparency on environmental impacts, as well as circular and low-CO<sub>2</sub> products.

**Guide to assessing product sustainability** is a white paper that clarifies global eco-label standards and how to interpret environmental declarations.

[Learn more about Green Premium >](#)

[Guide to assess a product's sustainability >](#)



Transparency RoHS/REACH

## Resource performance

Upgraded Components Available

## Well-being performance

RoHS Exemption Information Yes

## Certifications & Standards

**Reach Regulation** [REACH Declaration](#)

**Eu Rohs Directive** Pro-active compliance (Product out of EU RoHS legal scope)

**China Rohs Regulation** [China RoHS declaration](#)

**Environmental Disclosure** [Product Environmental Profile](#)

**Weee** The product must be disposed on European Union markets following specific waste collection and never end up in rubbish bins

**Circularity Profile** [End of Life Information](#)

Dimensions Drawings

Dimensions

---

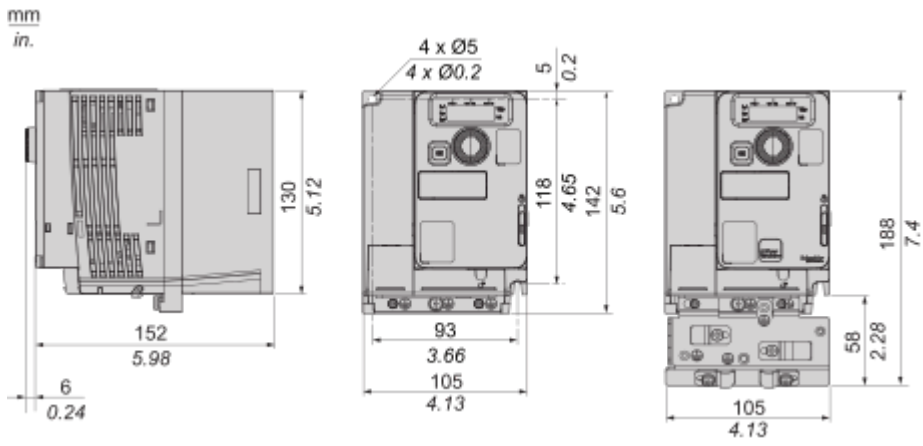

Mounting and Clearance

Mounting Types

---

Individual with Ventilation Cover

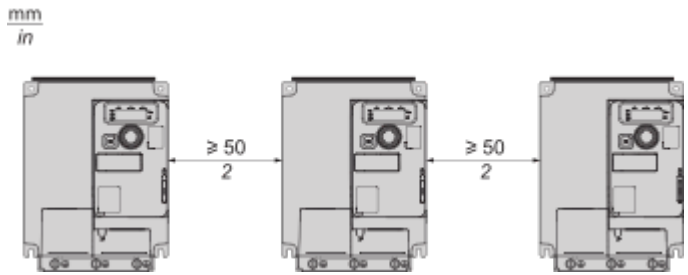

Free space  $\geq 50$  mm (2 in.) on each side, with vent cover fitted.  
Mounting type A is suitable for drive operation at surrounding air temperature less or equal to 50 °C (122 °F)

Side by Side, Ventilation Cover Removed

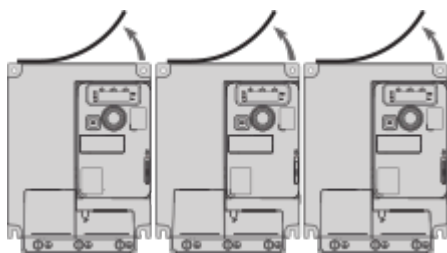

Drives mounted side-by-side, vent cover should be removed. The degree of protection becomes IP20.

Individual, Ventilation Cover Removed

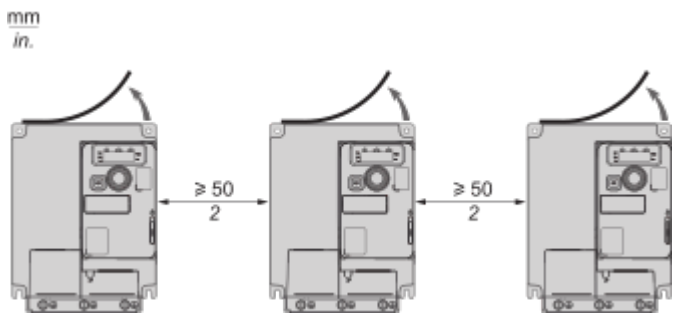

Free space  $\geq 50$  mm (2 in.) on each side. Vent cover should be removed for operation at surrounding air temperature above 50 °C (122 °F). The degree of protection becomes IP20.

Connections and Schema

Wiring

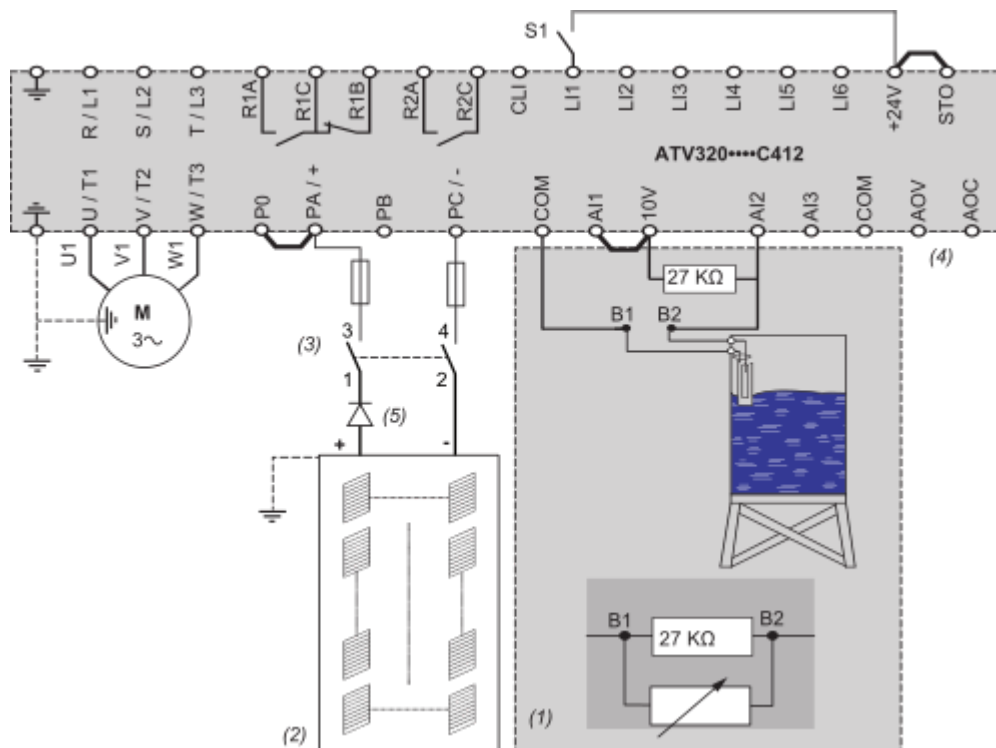

- (1) Tank water / liquid probe is optional.
- (2) The photovoltaic modules used shall comply with UL 1703. The solar panels and the drive input shall be in compliance with NEC article 690. For the photovoltaic installation ground connection, safety instructions and orientation, refer to the photovoltaic panel user manual.
- (3) Protection according to the concerned voltage, current and according to the photovoltaic arrays manual.
- (4) For AOC or AOV diagnostic values on ATV320 Solar drive.
- (5) On some applications, a blocking diode is mandatory.

**NOTE:** Check that the Logic Input switch is on Source position:





Performance Curves

Derating Curves

---

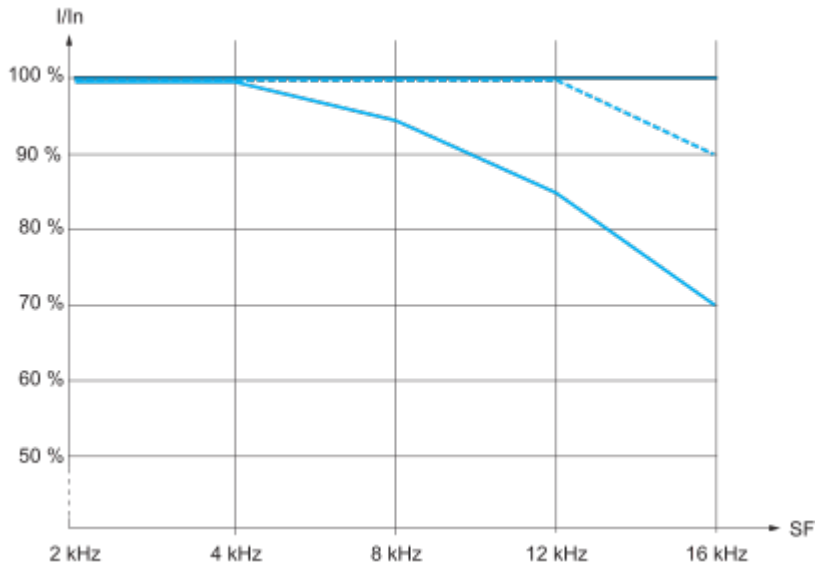

— 40 °C (104 °F) - Mounting type A, B and C  
- - - 50 °C (122 °F) - Mounting type A, B and C  
— 60 °C (140 °F) - Mounting type B and C  
**In** : Nominal Drive Current  
**SF** : Switching Frequency

Image of product / Alternate images

Alternative

---





