



Main

Product or component type	Accessory kit
Accessory / separate part destination	Ultrasonic sensor
Product compatibility	XXA - ultrasonic sensor[RETURN]XXS - ultrasonic sensor
Accessory / separate part categor	Configuration accessories
Accessory / separate part type	Configuration software

Complementary

[Us] rated supply voltage	24 V DC
Supply voltage limits	14...30 V
Power consumption in W	4 W
Local signalling	LED (green) for power supply LED (orange) for communication LED (red) for error
Maximum cable distance between devices	3000 mm
Transmission rate	19200 bps
Connector type	5 pins M12 female connector 5 pins M12 male connector
Integrated connection type	USB type A 0.5 m
Material	Plastic and metal

Environment

Standards	CE
IP degree of protection	IP40 conforming to IEC 60529
Ambient air temperature for storage	-20...45 °C
Ambient air temperature for operation	0...45 °C
Relative humidity	95 % without condensation

Packing Units

Unit Type of Package 1	PCE
Number of Units in Package 1	1
Package 1 Height	8.0 cm
Package 1 Width	17.0 cm
Package 1 Length	25.0 cm
Package 1 Weight	600.0 g
Unit Type of Package 2	S02
Number of Units in Package 2	2
Package 2 Height	15 cm
Package 2 Width	30 cm
Package 2 Length	40 cm
Package 2 Weight	1.655 kg

Dimensions

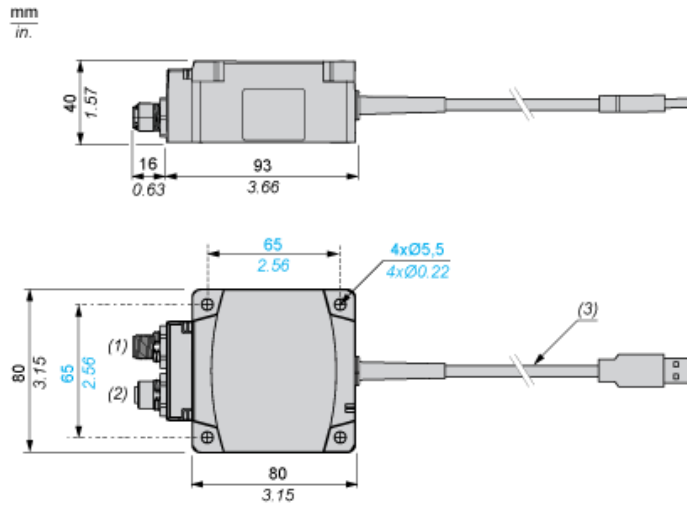

- (1) : Male M12 connector, 5-pin: power supply
- (2) : Female M12 connector, 5-pin: sensor
- (3) : Cable length: 0.5 m/1.64 ft. (USB cable A type connector): PC

Connections

Interface Connector for Power Supply Adapter (M12 Male)

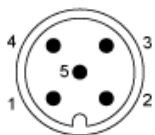

Pin number	Wire color	Description
1	BN: Brown	+14...30 VDC
2	WH: White	Output 2 (1) (2)
3	BU: Blue	0 VDC
4	BK: Black	Output 1 (1)
5	–	Not used (3)

Interface Connector for Sensor (M12 Female)

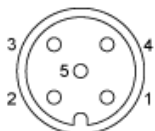

- (1) : Output is only active during the “echo display” mode and “measure” mode.
 (2) : Output 2 is not available on all sensors.
 (3) : The 5th pins of the M12 male and M12 female connectors are electrically connected to one another.

Pin number	Description
1	Power out to sensor
2	Software communication
3	0 VDC
4	Software communication
5	Not used (3)