

# QUINT4-PS/1AC/24DC/20/+

## Power supply unit



### Data sheet

108751\_en\_02a

© Phoenix Contact

2024-04-09

## 1 Description

QUINT POWER power supply with integrated decoupling MOSFET, SFB Technology, and preventive function monitoring ensures superior system availability.

### Powerful

- SFB Technology: 6 times the nominal current for 15 ms
- Power reserves:  
Static boost of up to 125% ( $P_N$ ) for a sustained period  
Dynamic boost of up to 200% ( $P_N$ ) for 5 s

### Robust

- Mains buffering  $\geq 20$  ms
- High electrical immunity, thanks to integrated gas discharge tube, e.g., surge of 6 kV/1.4 kA (8/20  $\mu$ s)
- ATEX/IECEx approval with protective coating

### Secure

- Safety integrity level 3 (SIL 3) for Overvoltage Protection

### Preventive

- Comprehensive signaling:  
Analog signal, digital signal, relay contact, LED bar graph

### Can be ordered pre-configured

- Perform configuration online and order 1 or more units

### Technical data (short form)

Input voltage range	100 V AC ... 240 V AC -15 % ... +10 %
Mains buffering	typ. 36 ms (120 V AC) typ. 36 ms (230 V AC)
Nominal output voltage ( $U_N$ )	24 V DC
Setting range of the output voltage ( $U_{Set}$ )	24 V DC ... 28 V DC
Nominal output current ( $I_N$ )	20 A
Static Boost ( $I_{Stat.Boost}$ )	25 A
Dynamic Boost ( $I_{Dyn.Boost}$ )	30 A (5 s)
Selective Fuse Breaking ( $I_{SFB}$ )	120 A (15 ms)
Output power ( $P_N$ )	480 W
Output power ( $P_{Stat. Boost}$ )	600 W
Output power ( $P_{Dyn. Boost}$ )	720 W
Efficiency	typ. 92.7 % (120 V AC) typ. 94.2 % (230 V AC)
Residual ripple	< 30 mV <sub>pp</sub>
MTBF (IEC 61709, SN 29500)	> 524000 h (40 °C)
Ambient temperature (operation)	-40 °C ... 75 °C > 60 °C Derating: 2,5 %/K
Dimensions W/H/D	70 mm / 130 mm / 125 mm
Weight	1.3 kg



All technical specifications are nominal and refer to a room temperature of 25 °C and 70 % relative humidity at 100 m above sea level.

<b>2</b>	<b>Table of contents</b>	
1	Description .....	1
2	Table of contents .....	2
3	Ordering data .....	3
4	Technical data .....	4
5	Safety and installation notes .....	15
6	High-voltage test (HIPOT) .....	17
7	Structure of the power supply .....	19
8	Mounting/removing the power supply .....	22
9	Device connection terminal blocks .....	25
10	Functional Safety (SIL) .....	26
11	Output characteristic curves .....	27
12	Configuring the power supply .....	30
13	Boost currents .....	31
14	SFB Technology .....	33
15	Signaling.....	38
16	Operating modes .....	46
17	Derating.....	48

### 3 Ordering data

Description	Type	Item no.	Pcs./Pkt.
Primary-switched QUINT POWER supply for DIN rail mounting, with selectable output characteristic curve and SFB Technology (selective fuse breaking), protective coating and integrated decoupling MOSFET, input: 1-phase, output: 24 V DC / 20 A	QUINT4-PS/1AC/24DC/20/+	2904617	1



Versions of the primary-switched QUINT POWER power supply with SFB Technology (selective fuse breaking), which are configured online, can now be ordered in batches of one or more using the following web code: [phoenixcontact.net/webcode/#0852](http://phoenixcontact.net/webcode/#0852)

Accessories	Type	Item no.	Pcs./Pkt.
Universal wall adapter for securely mounting the device in the event of strong vibrations. The device is screwed directly onto the mounting surface. The universal wall adapter is attached on the top/bottom.	UWA 182/52	2938235	1
2-piece universal wall adapter for securely mounting the device in the event of strong vibrations. The profiles that are screwed onto the side of the device are screwed directly onto the mounting surface. The universal wall adapter is attached on the left/right.	UWA 130	2901664	1
Near Field Communication (NFC) programming adapter with USB interface for the wireless configuration of NFC-capable products from Phoenix Contact with software. A separate USB driver is not required.	TWN4 MIFARE NFC USB ADAPTER	2909681	1
Pluggable device protection, according to type 3/class III, for 1-phase power supply networks with separate N and PE (3-conductor system: L1, N, PE), with integrated surge-proof fuse and remote indication contact. Also suitable for DC applications.	PLT-SEC-T3-230-FM	2905229	1
Electronic circuit breaker, number of positions: 1, mounting type: DIN rail: 35 mm	CBMC E4 24DC/1-4A NO	2906031	1
Electronic circuit breaker, number of positions: 1, mounting type: DIN rail: 35 mm	CBMC E4 24DC/1-10A NO	2906032	1
Electronic circuit breaker, number of positions: 1, mounting type: DIN rail: 35 mm	CBMC E4 24DC/1-4A+ IOL	2910410	1
Electronic circuit breaker, number of positions: 1, mounting type: DIN rail: 35 mm	CBMC E4 24DC/1-10A IOL	2910411	1
Electronic circuit breaker, number of positions: 1, mounting type: DIN rail: 35 mm	CBM E4 24DC/0.5-10A NO-R	2905743	1
Electronic circuit breaker, number of positions: 1, mounting type: DIN rail: 35 mm	CBM E8 24DC/0.5-10A NO-R	2905744	1



The range of accessories is being continuously extended. The current range of accessories can be found in the download area for the product.

## 4 Technical data

### Input data



Unless otherwise stated, all data applies for 25°C ambient temperature, 230 V AC input voltage, and nominal output current ( $I_N$ ).

Input voltage range	100 V AC ... 240 V AC -15 % ... +10 % 110 V DC ... 250 V DC -18 % ... +40 %
Electric strength, max.	300 V AC 60 s
Frequency range ( $f_N$ )	50 Hz ... 60 Hz -10 % ... +10 %
Frequency ( $f_R$ ) for railway power supply systems	16.7 Hz (acc. to EN 50163)



Railway power supply systems can be operated at 16.7 Hz. Use conditions and technical data on request.

Current draw typ.	6.8 A (100 V AC) 5.5 A (120 V AC) 2.8 A (230 V AC) 2.7 A (240 V AC) 6 A (110 V DC) 2.5 A (250 V DC)
-------------------	--------------------------------------------------------------------------------------------------------------------



The specified values for current consumption apply for operation in the static boost ( $P_N \times 125\%$ ).

Discharge current to PE typical	< 3.5 mA 1.7 mA (264 V AC, 60 Hz)
Mains buffering	typ. 36 ms (120 V AC) typ. 36 ms (230 V AC)
Switch-on time	< 1 s
Typical response time from SLEEP MODE	300 ms
Protective circuit	Transient surge protection Varistor, gas-filled surge arrester
Inrush current limitation after 1 ms	10 A
Inrush current integral ( $I^2t$ )	< 0.3 A <sup>2</sup> s
Input fuse slow-blow, internal	12 A



During the first few microseconds, the current flow into the filter capacitors is excluded.



The SCCR value (short-circuit current rating) of the power supply unit corresponds to the SCCR value of the backup fuse (see input protection table).



The external backup fuse must be approved for the (AC) supply voltage used and the voltage level.

Input protection , AC ( to be connected externally upstream )							
Input current $I_{In}$ Input protection	Circuit breaker					Neozed fuse or equivalent	Power switch
Characteristics	A	B	C	D	K	gG	$\leq 13 \times I_{In}$ (maximum magnetic tripping)
4 A	-	-	-	-	-	✓	-
6 A	-	-	-	-	-	✓	-
8 A	-	✓	✓	✓	✓	✓	✓
10 A	✓	✓	✓	✓	✓	✓	✓
13 A	✓	✓	✓	✓	✓	✓	✓
16 A	✓	✓	✓	✓	✓	✓	✓

**Electric strength of the insulation**

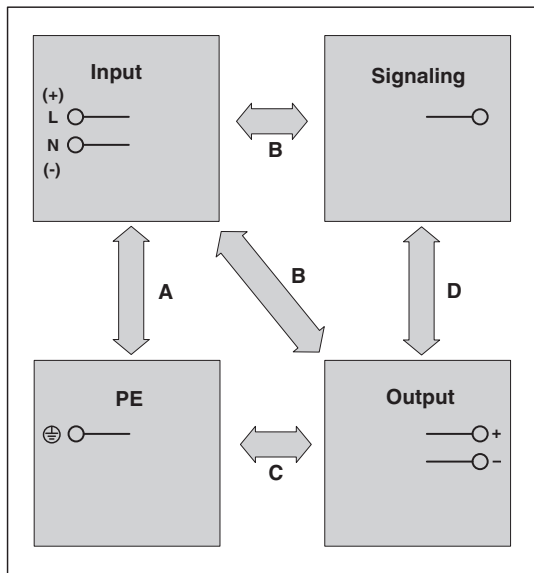

	A	B	C	D
Type test	2.5 kV AC	4 kV AC	0.85 kV AC	0.5 kV AC
Production test	2 kV AC	2 kV AC	0.85 kV DC	0.5 kV DC
Field test (with gas-filled surge arrester)	0.8 kV AC 1.1 kV DC	0.8 kV AC 1.1 kV DC	0.85 kV DC	0.5 kV DC
Field test (gas-filled surge arrester de-contacted)	2 kV AC 2.83 kV DC	2 kV AC 2.83 kV DC	0.85 kV DC	0.5 kV DC

**POWER factor**

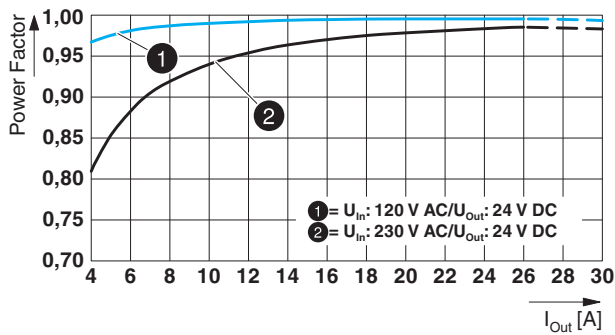

**Crest factor**

**120 V AC**

**230 V AC**

typ. 1.54

typ. 1.6

**Input current vs. output current**

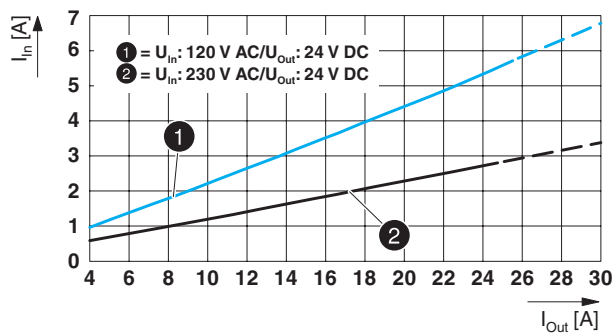

**Input connection data**

Connection method	Screw connection
Conductor cross section, rigid	0.2 mm <sup>2</sup> ... 6 mm <sup>2</sup>
Conductor cross section, flexible	0.2 mm <sup>2</sup> ... 4 mm <sup>2</sup>
Conductor cross section flexible, with ferrule with plastic sleeve	0.25 mm <sup>2</sup> ... 4 mm <sup>2</sup>
Conductor cross section flexible, with ferrule without plastic sleeve	0.25 mm <sup>2</sup> ... 4 mm <sup>2</sup>
Conductor cross section AWG	30 ... 10
Stripping length	8 mm
Tightening torque	0.5 Nm ... 0.6 Nm

**Output data**

Nominal output voltage ( $U_N$ )	24 V DC
Setting range of the output voltage ( $U_{Set}$ ) ( constant capacity )	24 V DC ... 28 V DC
Nominal output current ( $I_N$ )	20 A
Static Boost ( $I_{Stat.Boost}$ )	25 A

**Output data**

Dynamic Boost ( $I_{Dyn.Boost}$ )	30 A (5 s)
Selective Fuse Breaking ( $I_{SFB}$ )	120 A (15 ms)
Magnetic circuit breaker tripping	A1...A16 / B2...B13 / C1...C6 / Z1...Z16
Control deviation Static load change 10 % ... 90 %	< 0.5 %
Control deviation Dynamic load change 10 % ... 90 %, (10 Hz)	< 2 %
Control deviation change in input voltage $\pm 10$ %	< 0.25 %
Short-circuit-proof	yes
No-load proof	yes
Residual ripple ( with nominal values )	< 30 mV <sub>pp</sub>
Connection in parallel	yes, for redundancy and increased capacity
Connection in series	yes
Feedback voltage resistance	$\leq 35$ V DC
Protection against overvoltage at the output (OVP)	< 30 V DC (double protection with shut off within 20 ms)
Rise time typical	< 1 s ( $U_{Out} = 10$ % ... 90 %)

**Output connection data**

Connection method	Screw connection
Conductor cross section, rigid	0.2 mm <sup>2</sup> ... 6 mm <sup>2</sup>
Conductor cross section, flexible	0.2 mm <sup>2</sup> ... 4 mm <sup>2</sup>
Conductor cross section flexible, with ferrule with plastic sleeve	0.25 mm <sup>2</sup> ... 4 mm <sup>2</sup>
Conductor cross section flexible, with ferrule without plastic sleeve	0.25 mm <sup>2</sup> ... 4 mm <sup>2</sup>
Conductor cross section AWG	30 ... 10
Stripping length	8 mm
Tightening torque	0.5 Nm ... 0.6 Nm

**LED signaling**

$P_{Out} > 100$ %	LED lights up yellow, output power > 480 W
$P_{Out} > 75$ %	LED lights up green, output power > 360 W
$P_{Out} > 50$ %	LED lights up green, output power > 240 W
$U_{Out} > 0.9 \times U_{Set}$	LED lights up green
$U_{Out} < 0.9 \times U_{Set}$	LED flashes green

**Signal contact (configurable)**

Signal output (configurable) Out 1	
Digital	0 / 24 V DC , 20 mA
Default	24 V DC , 20 mA ( 24 V DC for $U_{Out} > 0.9 \times U_{Set}$ )
Signal output (configurable) Out 2	
Digital	0 / 24 V DC , 20 mA
Analog	4 mA ... 20 mA $\pm 5$ % (Load $\leq 400 \Omega$ )
Default	24 V DC , 20 mA ( 24 V DC for $P_{Out} < P_N$ )

Signal contact (configurable)	
Relay contact (configurable) 13/14	
Function	N/O contact
Default	closed ( $U_{out} > 0.9 U_{Set}$ )
Maximum contact load	24 V DC 1 A , 30 V AC/DC 0.5 A
Control input (configurable) Rem	
Function	Output power ON/OFF (SLEEP MODE)
Default	Output power ON (>40 k $\Omega$ /24 V DC/open bridge between Rem and SGnd)
Signal ground SGnd	Reference potential for Out1, Out2, and Rem

Signal connection data	
Connection method	Push-in connection
Conductor cross section, rigid	0.2 mm <sup>2</sup> ... 1.5 mm <sup>2</sup>
Conductor cross section, flexible	0.2 mm <sup>2</sup> ... 1.5 mm <sup>2</sup>
Conductor cross section flexible, with ferrule with plastic sleeve	0.2 mm <sup>2</sup> ... 0.75 mm <sup>2</sup>
Conductor cross section flexible, with ferrule without plastic sleeve	0.2 mm <sup>2</sup> ... 1.5 mm <sup>2</sup>
Conductor cross section AWG	24 ... 16
Stripping length	8 mm

Reliability	230 V AC
MTBF (IEC 61709, SN 29500)	> 868000 h (25 °C) > 524000 h (40 °C) > 239000 h (60 °C)
MTBF (MIL HDBK 217F, Ground Fixed GF)	> 303000 h (25 °C) > 193000 h (40 °C) > 97000 h (60 °C)

Life expectancy (electrolytic capacitors) Output current ( $I_{Out}$ )	120 V AC	230 V AC
10 A	> 392000 h ( 40 °C )	> 447000 h ( 40 °C )
20 A	> 133000 h ( 40 °C )	> 176000 h ( 40 °C )
20 A	> 378000 h ( 25 °C )	> 499000 h ( 25 °C )



The expected service life is based on the capacitors used. If the capacitor specification is observed, the specified data will be ensured until the end of the stated service life. For runtimes beyond this time, error-free operation may be reduced. The specified service life of more than 15 years is simply a comparative value.

Switching frequency	Min.	Max.
PFC stage	50.00 kHz	70.00 kHz
Auxiliary converter stage	90.00 kHz	110.00 kHz
Main converter stage	70.00 kHz	330.00 kHz



General data	
Degree of protection	IP20
Protection class	I
Flammability rating according to UL 94 (housing / terminal blocks)	V0
Side element version	Aluminum
Hood version	Stainless steel X6Cr17
Dimensions W / H / D (state of delivery)	70 mm / 130 mm / 125 mm
Dimensions W / H / D (90° turned)	122 mm / 130 mm / 73 mm
Weight	1.3 kg

Power dissipation	120 V AC	230 V AC
Maximum no-load power dissipation	< 5 W	< 5 W
Power dissipation SLEEP MODE	< 3 W	< 3 W
Power loss nominal load max.	< 38 W	< 30 W

Efficiency	120 V AC	230 V AC
	typ. 92.7 %	typ. 94.2 %

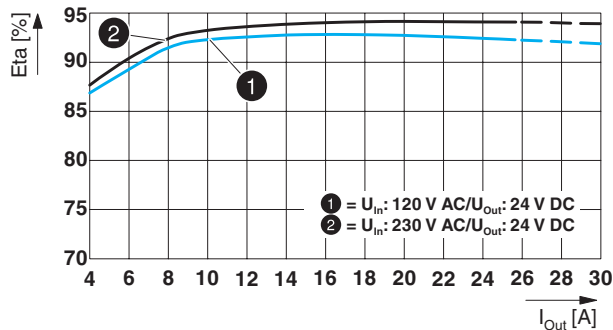

Ambient conditions	
Ambient temperature (operation)	-40 °C ... 75 °C (> 60 °C Derating: 2,5 %/K)
 The ambient temperature (operation) refers to UL 508 surrounding air temperature.	
Ambient temperature (storage/transport)	-40 °C ... 85 °C
Max. permissible relative humidity (operation)	≤ 100 % (at 25 °C, non-condensing)
Installation height	≤ 5000 m (> 2000 m, observe derating)
Vibration (operation)	5 Hz ... 100 Hz resonance search 2.3g, 90 min., resonance frequency 2.3g, 90 min. (according to DNV GL Class C)
Shock	18 ms, 30g, in each space direction (according to IEC 60068-2-27)
Degree of pollution	2
Climatic class	3K22 (in accordance with EN 60721-3-3)
Overvoltage category	
EN 61010-1	II (≤ 5000 m)
EN 62477-1	III (≤ 2000 m)
EN 61558-2-16	II (≤ 2000 m)

**Standards**

Safety transformers for power supply units	EN 61558-2-16
Electrical safety (of information technology equipment)	IEC 61010-2-201 (SELV)
Electrical safety (of control and regulation devices)	IEC 61010-1
Protective extra-low voltage	IEC 61010-1 (SELV) IEC 61010-2-201 (PELV)
Safe isolation	IEC 61558-2-16 IEC 61010-2-201
Limitation of mains harmonic currents	EN 61000-3-2
Network version/undervoltage	SEMI F47-0706, EN 61000-4-11
Rail applications	EN 50121-3-2 EN 50121-4 EN 50121-5 EN 50163 IEC 62236-3-2 IEC 62236-4 IEC 62236-5
EMC requirements, power plant	IEC 61850-3 EN 61000-6-5
HART FSK Physical Layer Test Specification Compliance	Output voltage $U_{Out}$ compliant
Explosive atmospheres	IEC 60079-0 IEC 60079-7 IEC 60079-11 IEC 60079-15

**Approvals**

ATEX	SIQ 21 ATEX 286 X ⊕ II 3 G Ex ec ic nC IIC T4 Gc
IECEX	IECEX SIQ 18.0005X Ex ec ic nC IIC T4 Gc
UL	UL Listed UL 508 UL/C-UL Recognized UL 60950-1 UL ANSI/ISA-12.12.01 Class I, Division 2, Groups A, B, C, D (Hazardous Location)
CSA	CAN/CSA-C22.2 No. 60950-1-07 CSA-C22.2 No. 107.1-01
SIQ	CB-Scheme (IEC 61010-1, IEC 61010-2-201)
Functional Safety in accordance with IEC 61508	SIL 3, HFT = 1 (Overvoltage Protection)
Shipbuilding	DNV

<b>Electromagnetic compatibility Conformance with EMC Directive 2014/30/EU</b>		
<b>Interference emission in accordance with EN 61000-6-3 (residential and commercial) and EN 61000-6-4 (industrial)</b>		
<b>CE basic standard</b>	<b>Minimum normative requirements</b>	<b>Higher requirements in practice (covered)</b>
Conducted noise emission EN 55016	EN 61000-6-4 (Class A)	EN 61000-6-3 (Class B)
Noise emission EN 55016	EN 61000-6-4 (Class A)	EN 61000-6-3 (Class B)
Harmonic currents EN 61000-3-2	EN 61000-3-2 (Class A)	EN 61000-3-2 (Class A)
Flicker EN 61000-3-3	not required	EN 61000-3-3
<b>Noise emission for marine approval</b>		
	<b>Minimum normative requirements of DNV GL</b>	<b>Higher requirements in practice of DNV GL (covered)</b>
DNV conducted interference emission	Class A Area power distribution	Class A Area power distribution
DNV interference radiation	Class A Area power distribution	Class B Bridge and deck area
<b>Immunity in accordance with EN 61000-6-1 (residential), EN 61000-6-2 (industrial), and EN 61000-6-5 (power station equipment zone), IEC/EN 61850-3 (power supply)</b>		
<b>CE basic standard</b>	<b>Minimum normative requirements of EN 61000-6-2 (CE) (immunity for industrial environments)</b>	<b>Higher requirements in practice (covered)</b>
Electrostatic discharge EN 61000-4-2		
Housing contact discharge	4 kV (Test Level 2)	8 kV (Test Level 4)
Housing air discharge	8 kV (Test Level 3)	15 kV (Test Level 4)
Comments	Criterion B	Criterion A
Electromagnetic HF field EN 61000-4-3		
Frequency range	80 MHz ... 1 GHz	80 MHz ... 1 GHz
Test field strength	10 V/m (Test Level 3)	20 V/m (Test Level 3)
Frequency range	1.4 GHz ... 6 GHz	1 GHz ... 6 GHz
Test field strength	3 V/m (Test Level 2)	10 V/m (Test Level 3)
Comments	Criterion A	Criterion A
Fast transients (burst) EN 61000-4-4		
Input	2 kV (Test Level 3 - asymmetrical)	4 kV (Test Level 4 - asymmetrical)
Output	2 kV (Test Level 3 - asymmetrical)	4 kV (Test Level 4 - asymmetrical)
Signal	1 kV (Test Level 3 - asymmetrical)	4 kV (Test Level 4 - asymmetrical)
Comments	Criterion B	Criterion A

Immunity in accordance with EN 61000-6-1 (residential), EN 61000-6-2 (industrial), and EN 61000-6-5 (power station equipment zone), IEC/EN 61850-3 (power supply)			
CE basic standard		Minimum normative requirements of EN 61000-6-2 (CE) (immunity for industrial environments)	Higher requirements in practice (covered)
Surge voltage load (surge) EN 61000-4-5			
	Input	1 kV (Test Level 3 - asymmetrical) 2 kV (Test Level 3 - asymmetrical)	typ. 3 kV (Test Level 4 - symmetrical) typ. 6 kV (Test Level 4 - asymmetrical)
	Output	0.5 kV (Test Level 2 - symmetrical) 0.5 kV (Test Level 1 - asymmetrical)	1 kV (Test Level 3 - symmetrical) 2 kV (Test Level 3 - asymmetrical)
	Signal	1 kV (Test Level 2 - asymmetrical)	4 kV (Test Level 4 - asymmetrical)
	Comments	Criterion B	Criterion A
Conducted interference EN 61000-4-6			
	Input/Output/Signal	asymmetrical	asymmetrical
	Frequency range	0.15 MHz ... 80 MHz	0.15 MHz ... 80 MHz
	Voltage	10 V (Test Level 3)	10 V (Test Level 3)
	Comments	Criterion A	Criterion A
Power frequency magnetic field EN 61000-4-8			
		50 Hz , 60 Hz ( 30 A/m )	16.7 Hz , 50 Hz , 60 Hz ( 100 A/m 60 s )
		not required	50 Hz , 60 Hz ( 1 kA/m , 3 s )
		not required	0 Hz ( 300 A/m , DC, 60 s )
	Comments	Criterion A	Criterion A
Voltage dips EN 61000-4-11			
Input voltage ( 230 V AC , 50 Hz )			
	Voltage dip	70 % , 25 periods ( Test Level 2 )	70 % , 0.5 / 1 / 25 / 30 periods ( Test Level 2 )
	Comments	Criterion C	Criterion A: 0.5 / 1 / 25 / 30 periods
	Voltage dip	40 % , 10 periods ( Test Level 2 )	40 % , 5 / 10 / 50 periods ( Test Level 2 )
	Comments	Criterion C	Criterion A
	Voltage dip	0 % , 1 period ( Test Level 2 )	0 % , 0.5 / 1 / 5 / 50 / 250 periods ( Test Level 2 )
	Comments	Criterion B	Criterion A: 0.5 / 1 period Criterion B: 5 / 50 / 250 periods

<b>Additional basic standard EN 61000-6-5 (immunity in power station), IEC/EN 61850-3 (energy supply)</b>		
<b>Basic standard</b>	<b>Minimum normative requirements of EN 61000-6-5</b>	<b>Higher requirements in practice (covered)</b>
<b>Pulse-shape magnetic field EN 61000-4-9</b>		
	not required	1000 A/m
Comments	none	Criterion A
<b>Damped oscillating magnetic field EN 61000-4-10</b>		
	not required	100 kHz 110 A/m
	not required	1 MHz 110 A/m
Comments	none	Criterion A
<b>Attenuated sinusoidal oscillations (ring wave) EN 61000-4-12</b>		
Input	not required	2 kV (Test Level 4 - symmetrical)
	not required	4 kV (Test Level 4 - asymmetrical)
Comments	none	Criterion A
<b>Asymmetrical conducted disturbance variables EN 61000-4-16</b>		
Input, Output, Signals	15 Hz ... 150 Hz , 10 V on 1 V 150 Hz ... 1.5 kHz , 1 V 1.5 kHz ... 15 kHz , 1 V on 10 V 15 kHz ... 150 kHz , 10 V ( Test Level 3 )	15 Hz ... 150 Hz , 30 V on 3 V 150 Hz ... 1.5 kHz , 3 V 1.5 kHz ... 15 kHz , 3 V on 30 V 15 kHz ... 150 kHz , 30 V ( Test Level 4 )
	50 Hz , 60 Hz , 10 V (Permanent) 50 Hz , 60 Hz , 100 V (1 s)  ( Test Level 3 )	16.7 Hz , 50 Hz , 60 Hz , 30 V (Permanent) 150 Hz , 180 Hz , 30 V (Permanent) 16.7 Hz , 50 Hz , 60 Hz , 300 V (1 s) ( Test Level 4 )
Comments	Criterion A	Criterion A
<b>Attenuated oscillating wave EN 61000-4-18</b>		
Input, Output	1 MHz 1 kV ( Test Level 3 - symmetrical )	100 kHz , 1 MHz , 1 kV ( Test Level 3 - symmetrical )
	10 MHz , 1 kV 1 MHz 2.5 kV ( Test Level 3 - asymmetrical )	10 MHz , 1 kV 100 kHz , 1 MHz , 2.5 kV ( Test Level 3 - asymmetrical )
Signals	1 MHz , 1 kV ( Test Level 3 - symmetrical )	100 kHz , 1 MHz , 1 kV ( Test Level 3 - symmetrical )
	1 MHz , 2.5 kV ( Test Level 3 - asymmetrical )	100 kHz , 1 MHz , 2.5 kV ( Test Level 3 - asymmetrical )
Comments	Criterion B	Criterion A

**Key**

Criterion A	Normal operating behavior within the specified limits.
Criterion B	Temporary impairment to operational behavior that is corrected by the device itself.
Criterion C	Temporary adverse effects on the operating behavior, which the device corrects automatically or which can be restored by actuating the operating elements.

## 5 Safety and installation notes

### 5.1 Symbols used

Instructions and possible hazards are indicated by corresponding symbols in this document.



This is the safety alert symbol. It is used to alert you to potential personal injury hazards. Obey all safety measures that follow this symbol to avoid possible personal injuries.

There are different categories of personal injury that are indicated by a signal word.



#### **WARNING**

This indicates a hazardous situation which, if not avoided, could result in death or serious injury.



#### **CAUTION**

This indicates a hazardous situation which, if not avoided, could result in minor or moderate injury.



#### **WARNING: Explosion hazard**

This is the safety alert symbol. It is used to alert you to potential personal injury hazards. Obey all safety measures that follow this symbol to avoid possible personal injuries.

The following symbols are used to indicate potential damage, malfunctions, or more detailed sources of information.



#### **NOTE**

This symbol together with the signal word NOTE and the accompanying text alert the reader to a situation which may cause damage or malfunction to the device, hardware/software, or surrounding property.



This symbol and the accompanying text provide the reader with additional information or refer to detailed sources of information.

### 5.2 Safety and warning notes



#### **WARNING: Danger to life by electric shock!**

- Only skilled persons may install, start up, and operate the device.
- The power supply must be switched off from outside (e.g. via the line protection on the primary side).
- Never carry out work when voltage is present.
- Establish connection correctly and ensure protection against electric shock.
- Cover termination area after installation in order to avoid accidental contact with live parts (e. g., installation in control cabinet).
- Protection may be impaired if the equipment is used in a manner not specified by the manufacturer.



#### **CAUTION: Hot surface**

Depending on the ambient temperature and load on the power supply, the housing can become hot.



#### **NOTE**

- Observe the national safety and accident prevention regulations.
- Assembly and electrical installation must correspond to the state of the art.
- The power supply is a built-in device and is designed for mounting in a control cabinet.
- The IP20 degree of protection of the device is intended for use in a clean and dry environment.
- Observe mechanical and thermal limits.
- Ensure minimum clearances to external heat sources.
- Mount the power supply in the standard installation position. Position of the connection terminals ⊕/N/L below.
- Connect the housing to ground via protective conductor device terminal block ⊕.
- Make sure that the wiring on the primary side and the secondary side is adequately dimensioned and protected.
- Use copper cables for operating temperatures of >75 °C (ambient temperature <55 °C) >90 °C (ambient temperature <75 °C).
- For the connection parameters for wiring the power supply, such as the required stripping length with and without ferrule, refer to the technical data section.

- The power supply is approved for the connection to TN, TT and IT power grids (star networks) with a maximum phase-to-phase voltage of 240 V AC
- If the device is connected to the IT system, a two-pole circuit breaker is required in the application.
- Protect the device against foreign bodies penetrating it, e.g., paper clips or metal parts.
- The power supply is maintenance-free. Repairs may only be carried out by the manufacturer. The warranty no longer applies if the housing is opened.
- The power supply may only be used for its intended use.
- Relay contact 13/14 can be used to max. 30 V AC/ 24 V DC.



**NOTE: Damage to the Push-in connection terminal blocks is possible**

Do not plug test pins into the Push-in connection terminal blocks. The maximum pluggable depth of the Push-in connection terminal blocks is limited. In addition, when the test pin is plugged in, the unlocking button (pusher) is covered to such an extent that unlocking is not possible or only possible to an insufficient extent. If you do not push the unlocking button (pusher) down completely when you are pulling the test pin out, then the Push-in connection terminal block will become damaged.



**WARNING: Explosion hazard**

- Install the device in suitable housing with at least IP54 degree of protection in accordance with EN 60079-0 and EN 60079-7.
- This is assured with enclosure in type of protection Ex ec or Ex eb.
- The installation in the enclosure must be carried out in such a way that the ambient temperature is not exceeded during operation.
- The distance to other components or enclosure's wall shall be at least 15 mm (left, right) and 50 mm (top, bottom). For passive components that do not produce heat, the distance can be reduced to 5 mm (left, right).
- The category 3 device is suitable for installation in zone 2 potentially explosive areas in accordance with directive 2014/34/EU.
- The device is not designed for use in dust explosion hazardous atmosphere.

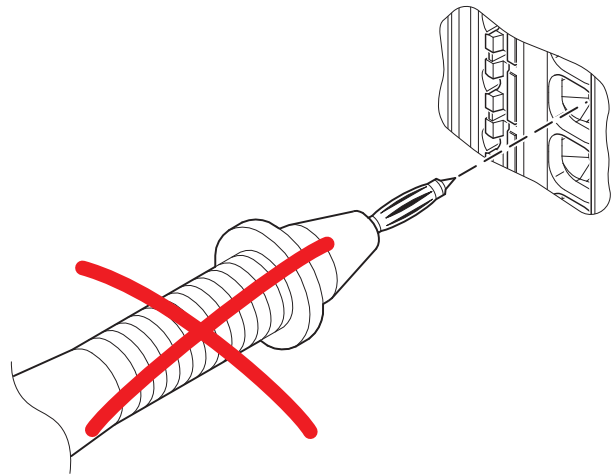

The continuous total output power may not exceed  $P_N$  at 60 °C ambient temperature and  $P_{Stat. Boost}$  at 40°C ambient temperature. Observe all the maximum output powers for all operating conditions.



## 6 High-voltage test (HIPOT)

This protection class I power supply is subject to the Low Voltage Directive and is factory tested. During the HIPOT test (high-voltage test), the insulation between the input circuit and output circuit is tested for the prescribed electric strength values, for example. The test voltage in the high-voltage range is applied at the input and output terminal blocks of the power supply. The operating voltage used in normal operation is a lot lower than the test voltage used.



High-voltage tests up to 0.8 kV AC / 1.1 kV DC can be performed as described.

For high-voltage tests > 0.8 kV AC / 1.1 kV DC, the gas-filled surge arrester must be disconnected.

The test voltage should rise and fall in ramp form. The relevant rise and fall time of the ramp should be at least two seconds.

### 6.1 High-voltage dielectric test (dielectric strength test)

In order to protect the user, power supplies (as electric components with a direct connection to potentially hazardous voltages) are subject to more stringent safety requirements. For this reason, permanent safe electrical isolation between the hazardous input voltage and the touch-proof output voltage as safety extra-low voltage (SELV) must always be ensured.

In order to ensure permanent safe isolation of the AC input circuit and DC output circuit, high-voltage testing is performed as part of the safety approval process (type test) and manufacturing (routine test).

### 6.2 High-voltage dielectric test during the manufacturing process

During the manufacturing process for the power supply, a high-voltage test is performed as part of the dielectric test in accordance with the specifications of IEC/UL/EN 61010-1. The high-voltage test is performed with a test voltage of at least 1.5 kV AC / 2.2 kV DC or higher. Routine manufacturing tests are inspected regularly by a certification authority.

### 6.3 High-voltage dielectric test performed by the customer

Apart from routine and type tests to guarantee electrical safety, the end user does not have to perform another high-voltage test on the power supply as an individual component. According to EN 60204-1 (Safety of machinery - Electrical equipment of machines) the power supply can be disconnected during the high-voltage test and only installed once the high-voltage test has been completed.

### 6.3.1 Performing high-voltage testing

If high-voltage testing of the control cabinet or the power supply as a stand-alone component is planned during final inspection and testing, the following features must be observed.

- The power supply wiring must be implemented as shown in the wiring diagram.
- The maximum permissible test voltages must not be exceeded.

Avoid unnecessary loading or damage to the power supply due to excessive test voltages.



For the relevant applicable test voltages and insulation distances, refer to the corresponding table (see technical data: electric strength of the insulation section).

Figure 1 Potential-related wiring for the high-voltage test

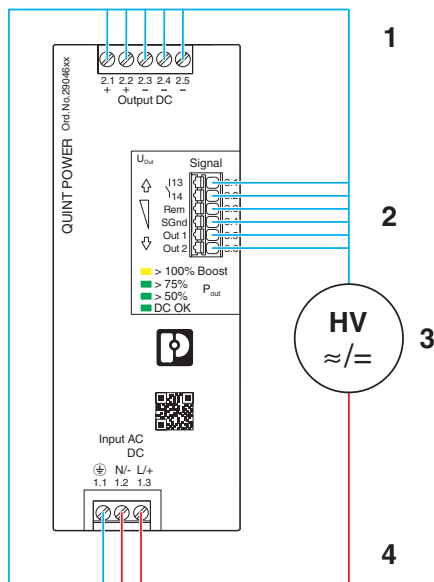

#### Key

No.	Designation	Color coding	Potential levels
1	DC output circuit	Blue	Potential 1
2	Signal contacts	Blue	Potential 1
3	High-voltage tester	--	--
4	AC input circuit	Red	Potential 2

### 6.3.2 Disconnecting the gas discharge tube

The built-in gas discharge tube inside the device ensures that the power supply is effectively protected against asymmetrical disturbance variables (e.g., EN 61000-4-5).

Each surge voltage test represents a very high load for the power supply. Therefore avoid unnecessary loading or damage to the power supply due to excessive test voltages. If necessary, the gas discharge tube inside the device can be disconnected in order to use higher test voltages. Following successful completion of testing, please reconnect the gas-discharge tube.

Figure 2 Disconnect gas discharge tube

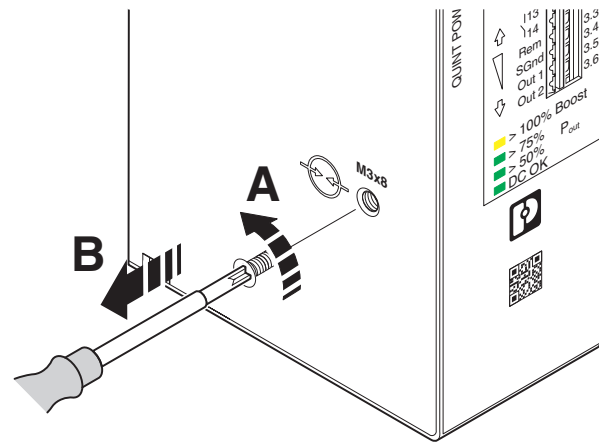

To disconnect the gas discharge tube, proceed as follows:

1. Remove power from the unit.
2. Unscrew the Phillips head screw completely and keep the gas discharge tube screw in a safe place. The gas-discharge tube is now disconnected and is no longer functional.
3. Perform the surge voltage test on the power supply.
4. Following successful high-voltage testing, screw the gas discharge tube screw fully back into the power supply.



**DANGER: Risk of electric shock or damage to the power supply due to using the wrong gas discharge tube screw**

To connect the gas-filled surge arrester, only use the gas-filled surge arrester screw that was originally installed in the power supply.

## 7 Structure of the power supply

The fanless convection-cooled power supply can be snapped onto all DIN rails in accordance with EN 60715.

### 7.1 Function elements

Figure 3 Operating and indication elements

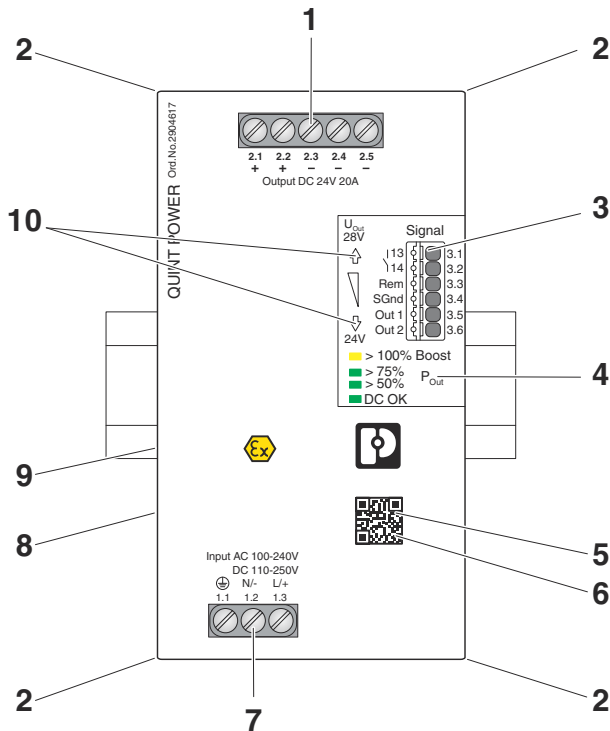

#### Key

No.	Designation
1	DC output voltage connection terminal blocks
2	Accommodation for cable binders
3	Signaling connection terminal blocks
4	Status and diagnostics indicators
5	Position NFC interface (Near Field Communication)
6	QR code web link
7	AC input voltage connection terminal blocks
8	Gas discharge tube for surge protection (left side of housing)
9	Universal DIN rail adapter (rear of housing)
10	Output voltage button ↓(-) / ↑(+)

### 7.2 Device dimensions

Figure 4 Device dimensions (dimensions in mm)

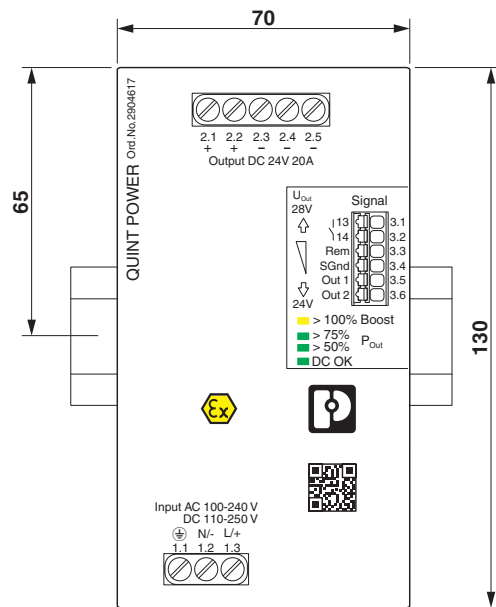
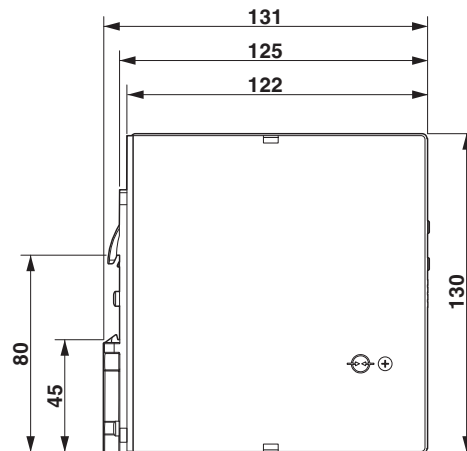

Figure 5 Device dimensions (dimensions in mm)





7.4 Block diagram

Figure 7 Block diagram

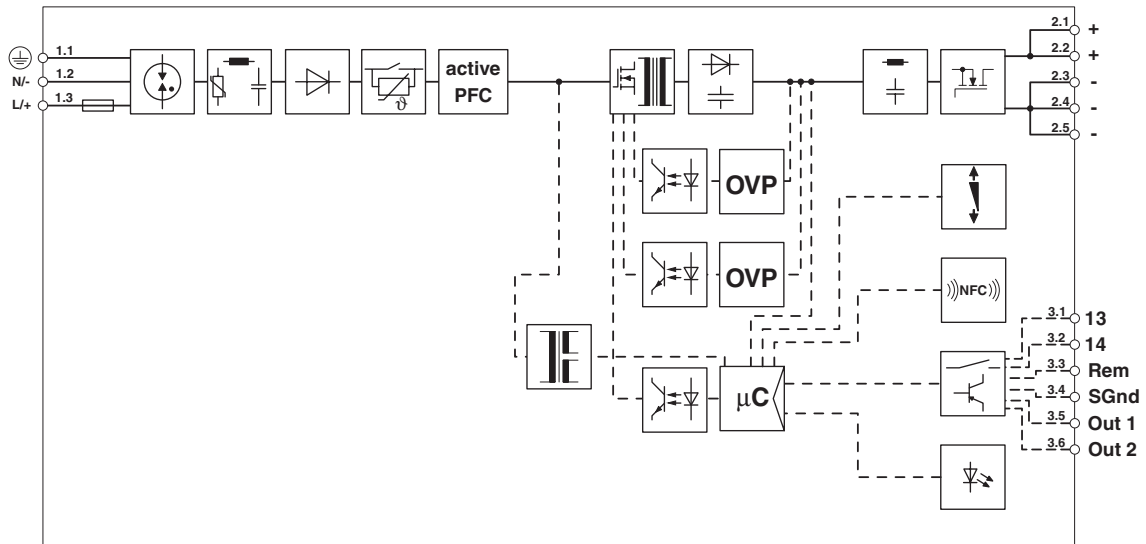

Key

Symbol	Designation
	Surge protection (gas discharge tube)
	Surge protection (varistor) with filter
	Bridge rectifier
	Inrush current limitation
	Power factor correction (PFC)
	Switching transistor and main transmitter (electrically isolating)
	Secondary rectification and smoothing
	Filter
	Auxiliary converter (electrically isolating)

Symbol	Designation
	Optocoupler (electrically isolating)
	Additional regulatory protection against surge voltage
	Relay contact and signal contacts
	Microcontroller
	Passive NFC interface (Near Field Communication)
	Output voltage button ↓(-) / ↑(+)
	Signal/display LEDs (P <sub>Out</sub> , DC OK)
	Decoupling MOSFET

## 8 Mounting/removing the power supply

### 8.1 Mounting the power supply unit

Proceed as follows to mount the power supply:

1. In the normal mounting position the power supply is mounted on the DIN rail from above. Make sure that the universal DIN rail adapter is in the correct position behind the DIN rail (A).
2. Then press the power supply down until the universal DIN rail adapter audibly latches into place (B).
3. Check that the power supply is securely attached to the DIN rail.

Figure 8 Snapping the power supply onto the DIN rail

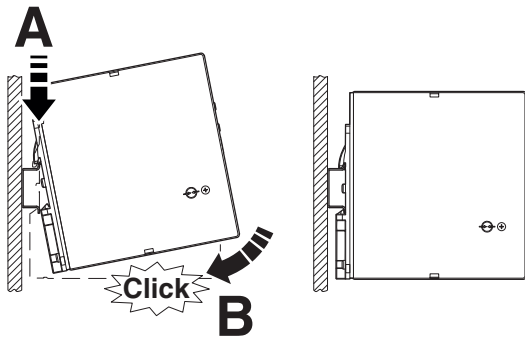

### 8.2 Removing the power supply unit

Proceed as follows to remove the power supply:

1. Take a suitable screwdriver and insert this into the lock hole on the universal DIN rail adapter (A).
2. Release the lock by lifting the screwdriver (B).
3. Carefully swivel the power supply forward (C) so that the lock slides back into the starting position.

4. Then separate the power supply from the DIN rail (D).

Figure 9 Removing the power supply from the DIN rail

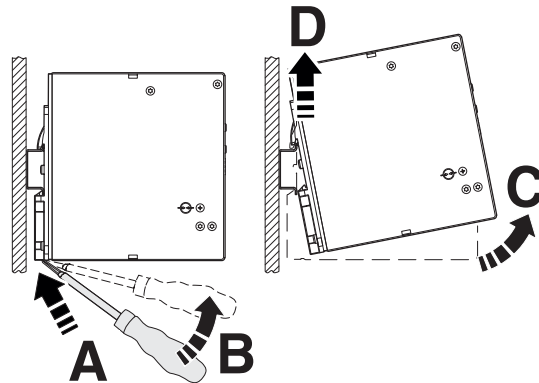

### 8.3 Retrofitting the universal DIN rail adapter

For installation in horizontal terminal boxes it is possible to mount the power supply at a 90° angle to the DIN rail.

No additional mounting material is required.



Use the Torx screws provided to attach the universal DIN rail adapter to the side of the power supply.

#### 8.3.1 Disassembling the universal DIN rail adapter

Proceed as follows to disassemble the universal DIN rail adapter that comes pre-mounted:

1. Remove the screws for the universal DIN rail adapter using a suitable screwdriver (Torx 10).
2. Separate the universal DIN rail adapter from the rear of the power supply.

Figure 10 Disassembling the universal DIN rail adapter

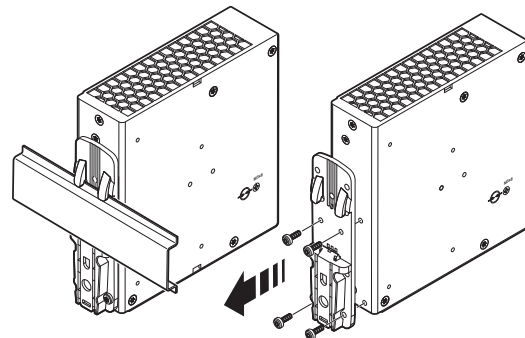

### 8.3.2 Mounting the universal DIN rail adapter

To mount the universal DIN rail adapter on the left side of the device, proceed as follows:

1. Position the universal DIN rail adapter on the left side of the housing so that the mounting holes are congruent with the hole pattern for the mounting holes.
2. Insert the Torx screws that were removed earlier into the appropriate hole pattern on the universal DIN rail adapter so that the necessary drill holes on the power supply can be accessed.
3. Screw the universal DIN rail adapter onto the power supply.



The maximum tightening torque of the Torx screw (Torx® T10) is 0.7 Nm.

Figure 11 Mounting the universal DIN rail adapter

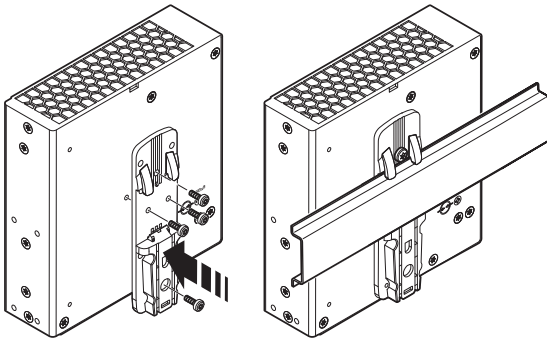

### 8.4 Retrofitting the universal wall adapter

The UWA 182/52 universal wall adapter (Item No. 2938235) or UWA 130 universal wall adapter (Item No. 2901664) is used to attach the power supply directly to the mounting surface.

The use of universal wall adapters is recommended under extreme ambient conditions, e.g., strong vibrations. Thanks to the tight screw connection between the power supply and the universal wall adapter or the actual mounting surface, an extremely high level of mechanical stability is ensured.



The power supply is attached to the UWA 182 or UWA 130 universal wall adapter by means of the Torx screws of the universal DIN rail adapter.

### 8.4.1 Mounting the UWA 182/52 universal wall adapter

Proceed as follows to disassemble the universal DIN rail adapter that comes pre-mounted:

1. Remove the screws for the universal DIN rail adapter using a suitable screwdriver (Torx 10).
2. Separate the universal DIN rail adapter from the rear of the power supply.
3. Position the universal wall adapter in such a way that the keyholes or oval tapers face up. The mounting surface for the power supply is the raised section of the universal wall adapter.
4. Place the power supply on the universal wall adapter in the normal mounting position (input voltage connection terminal blocks below).
5. Insert the Torx screws into the appropriate hole pattern on the universal wall adapter so that the necessary mounting holes on the power supply can be accessed.
6. Screw the universal wall adapter onto the power supply.

Figure 12 Mounting the UWA 182/52 universal wall adapter

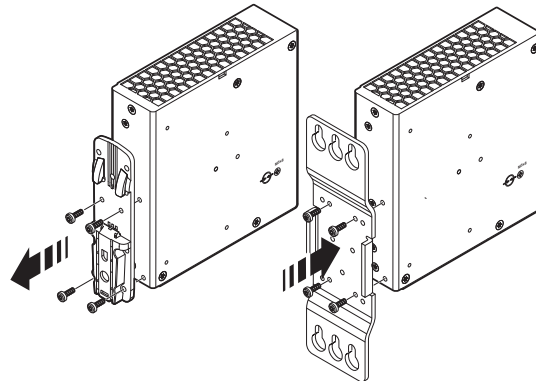

The maximum tightening torque of the Torx screw (Torx® T10) is 0.7 Nm.



Make sure you use suitable mounting material when attaching to the mounting surface.

### 8.4.2 Mounting the UWA 130 2-piece universal wall adapter

Proceed as follows to disassemble the universal DIN rail adapter that comes pre-mounted:

1. Remove the screws for the universal DIN rail adapter using a suitable screwdriver (Torx 10).
2. Separate the universal DIN rail adapter from the rear of the power supply.
3. Position the universal wall adapter. The mounting surface for the power supply is the raised section of the universal wall adapter.
4. Place the power supply on the universal wall adapter in the normal mounting position (input voltage connection terminal blocks below).
5. Insert the Torx screws into the appropriate hole pattern on the universal wall adapter so that the necessary mounting holes in the side flanges of the power supply can be accessed.
6. Screw the two-piece universal wall adapter onto the power supply.

Figure 13 Mounting the UWA 130 universal wall adapter

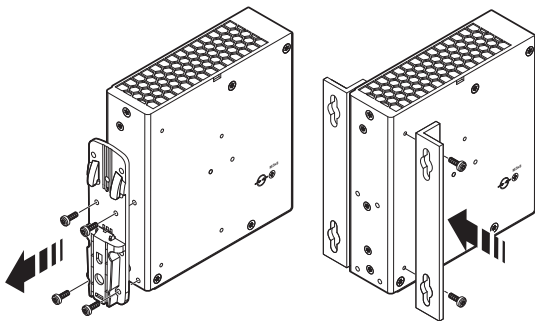

### 8.5 Fix connection wiring to the power supply

Two receptacles for the bundled attachment of the connection wiring are integrated in the left and right housing panel. Use cable binders to secure the connection wiring (optional WT-HF 3,6X140 - Item No. 3240744).

Proceed as follows to secure the connection wiring:

- Wire the power supply with sufficient connection reserve (input terminal blocks, output terminal blocks, signal terminal blocks)
- Bundle and set up the connection wiring so that the cooling grilles on the top and bottom of the housing are covered as little as possible.
- Thread the cable binders into the necessary receptacles for the cable binders.

Figure 14 Lay and align connection wiring

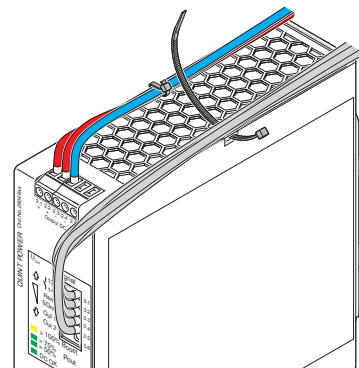

- Secure the connection wiring with the cable binders. Make sure that the connection wiring is attached safely and securely without damaging the connection wiring.

Figure 15 Secure connection wiring with cable binder

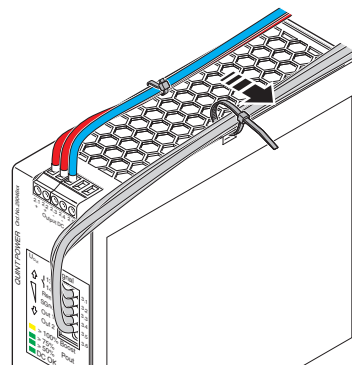



- Shorten the excess length of the cable ties.
- Then check again that the connection wiring is properly secured.

Figure 16 Shorten protruding ends of the cable binder

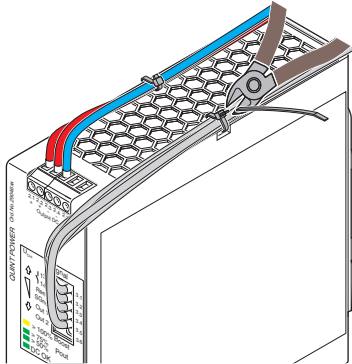

**NOTE:** Mechanical damage to the connection wiring caused by friction

In extreme ambient conditions, e.g., strong vibrations, protect the connection wiring against mechanical damage using additional insulation material. The additional insulation material for protecting the connection wiring is limited to the area where the cable binders are attached.

## 9 Device connection terminal blocks

The AC input and DC output terminal blocks on the front of the power supply feature screw connection technology. The signal level is wired without tools by means of Push-in connection technology.



For the necessary connection parameters for the connection terminal blocks, refer to the technical data section.

### 9.1 Input

The power supply is operated on single-phase AC systems or two outer conductors of three-phase systems. The power supply is connected on the primary side via the INPUT L/N/⊕ connection terminal blocks.



The power supply is approved for connection to TN, TT, and IT power grids with a maximum phase-to-phase voltage of 240 V AC.

Figure 17 Network types

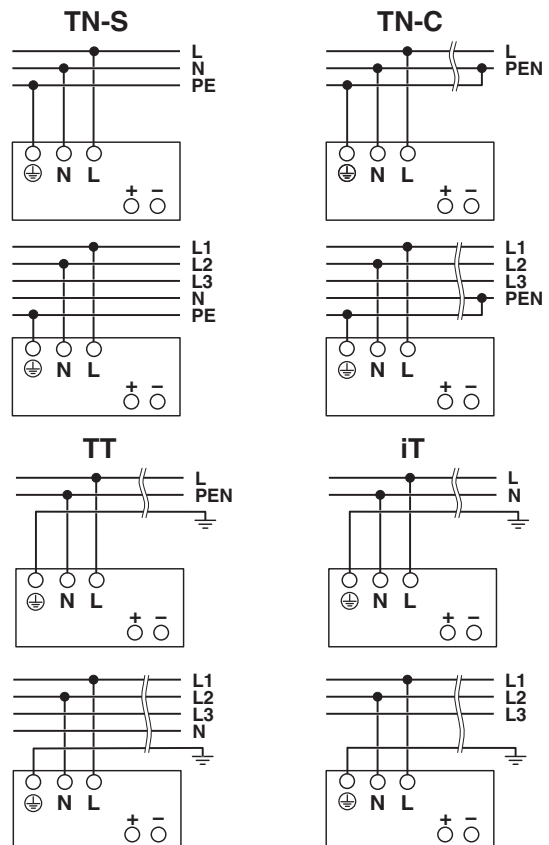

### 9.2 Protection of the primary side

Installation of the device must correspond to EN 61010-1 regulations. It must be possible to switch the device off using a suitable disconnection device outside the power supply. For example, the primary-side line protection is suitable for this (see technical data).



**DANGER: Hazardous voltage**

An all-pos. fuse must be present for operation on two outer conductors of a three-phase system.

### Protection for AC supply

Figure 18 Pin assignment for AC supply voltage

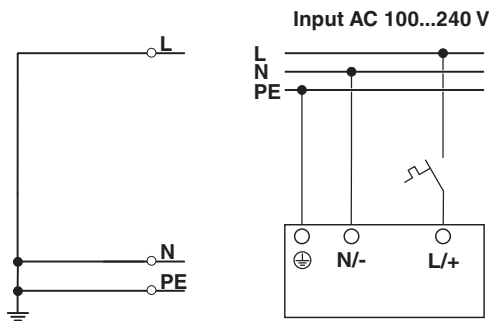

### Protection for DC supply

Figure 19 Pin assignment for DC supply voltage

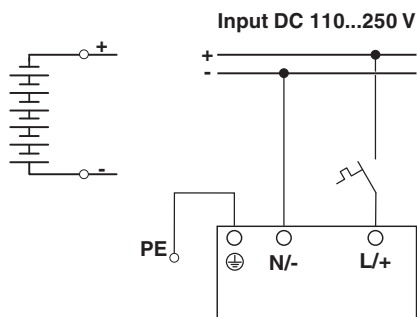

DC applications require upstream installation of a fuse that is permitted for the operating voltage.

### 9.3 Output

By default, the power supply is pre-set to a nominal output voltage of 24 V DC.

The output voltage is adjusted via the two arrow keys ↓(-) and ↑(+) on the front of the power supply.

When you press the arrow key once briefly, the output voltage is reduced ↓(-) or increased ↑(+) by 3 mV. When you press the arrow key for longer, the voltage is adjusted in 100 mV increments.

### 9.4 Protection of the secondary side

The power supply is electronically short-circuit-proof and no-load-proof. In the event of an error, the output voltage is limited



If sufficiently long connecting cables are used, fuse protection does not have to be provided for each individual load.

If each load is protected separately with its own protective device, the selective shutdown in the event of a fault enables the system to remain operational.

## 10 Functional Safety (SIL)







The overvoltage protection circuitry fulfils the requirements up to safety integrity level 3 (SIL 3; HFT = 1), and can be used in applications up to SIL 3 in accordance to IEC 61508 and IEC 61511.

The TÜV-approved protective circuit protects sensitive loads against surge voltages, thus preventing the risk of system downtime.

In the event of an internal error, the output voltage is limited to < 30 V DC before the power supply shuts off within 20 ms to protect the loads.

## 11 Output characteristic curves

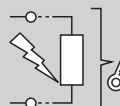
This section describes the various output characteristic curves together with their areas of application for customization to your specific application. The U/I Advanced characteristic curve is set by default.

							
<b>Application</b>	Normal load	System extension	Loads with high inrush current	Energy storage charging	Selective tripping of fuses	Keeps temperatures low in the event of faults	Short circuit, non-fused
<b>Your benefits</b>	Reliable power supply	A stable 24 V, even in the event of a sustained overload	No over-dimensioned power supply unit required	Fast charging	Parallel loads continue working	Low thermal stress in the event of faults	Enables configuration without fuse

### Characteristics

<b>U/I Advanced</b>	✓	✓	✓	✓	✓	✓	—
<b>Smart HICCUP</b>	✓	✓	✓	✓	—	✓	—
<b>FUSE MODE</b>	✓	✓	—	—	—	✓	✓

Symbol	Designation
✓	Suitable for the application
—	Not suitable for the application

### 11.1 U/I Advanced output characteristic curve

The preset U/I Advanced output characteristic curve is optimized for the following applications:

- For selective tripping of standard circuit breakers (SFB technology). The power supply supplies up to 6 times the nominal current for 15 ms. Loads connected in parallel continue working.
- When supplying loads with high switch-on currents, such as motors. The dynamic boost of the power supply supplies up to 200% of the nominal power for 5 s. This ensures that sufficient reserve energy is available; overdimensioning of the power supply is not necessary.
- For system extension. With the static boost, up to 125% of the nominal output power is available for a sustained period (up to 40°C).
- For fast energy storage charging (e.g., of batteries) to supply a wide range of loads. The power supply operates in the nominal operating range. Energy supply to the load is ensured.

Figure 20 U/I Advanced output characteristic curve

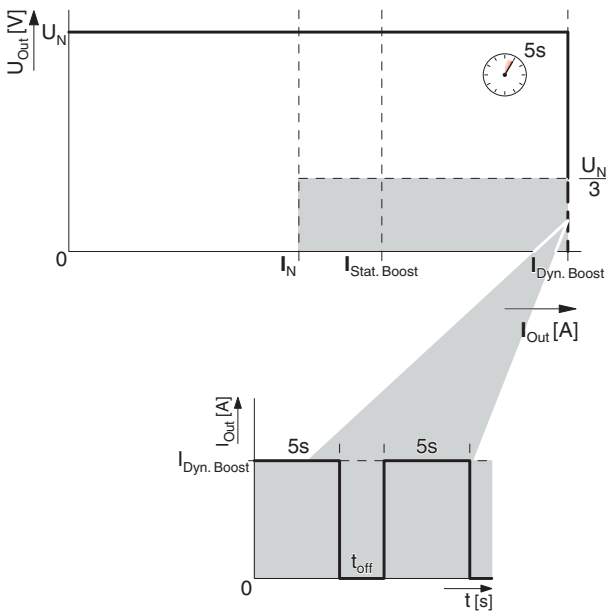

### 11.2 Smart HICCUP output characteristic curve

The SMART HICCUP output characteristic curve keeps the thermal load of the connecting cables at a low level in the event of a sustained overload. If loads are not protected or are protected in a way that is not permitted, the loads are supplied for 2 s. The DC output of the power supply is then switched off for 8 s. This procedure is repeated until the cause of the overload has been remedied.

The Smart HICCUP output characteristic curve is optimized for the following applications:

- If only a low short-circuit current is permitted.
- If following an overload or short circuit the output voltage should be made available again automatically.

Figure 21 Smart HICCUP output characteristic curve

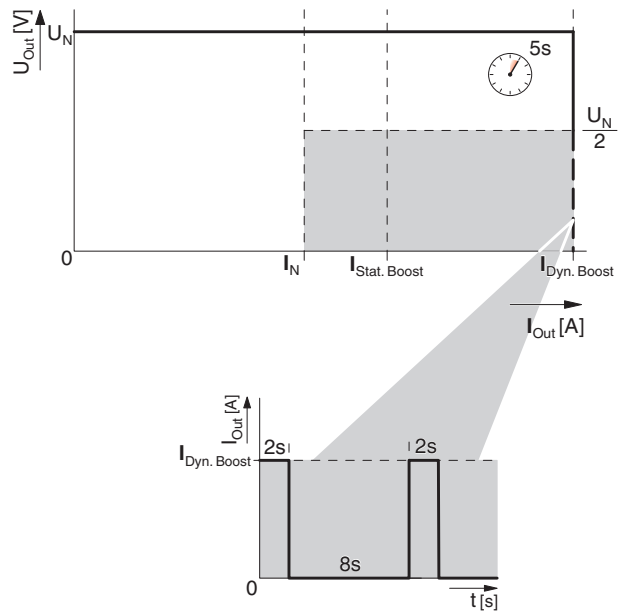

### 11.3 FUSE MODE output characteristic curve

In the event of an overload (e.g., short circuit), the power supply switches off the DC output permanently. The value of the switch-off threshold and the time period for which it may be exceeded can be freely selected. The power supply is restarted via the remote contact. As an option, the power supply can be switched on by switching the supply voltage on the primary side off and on.

Selecting the FUSE MODE output characteristic curve sets the following default values.

- $t_{Fuse} = 100 \text{ ms}$
- $I_{Fuse} = I_N$

Figure 22 FUSE MODE output characteristic curve

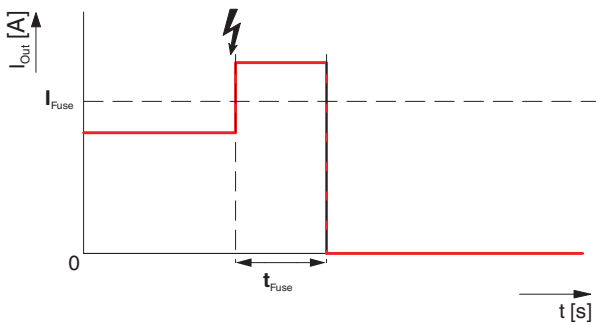

## 12 Configuring the power supply

With the fourth generation of the QUINT POWER power supply, it is now possible for the first time to adapt the behavior of the power supply. In addition to setting the output voltage and selecting the output characteristic curves, you can configure signal outputs Out 1, Out 2, and floating signal contact 13/14, for example. Configuration of the remote input for controlling the power supply or specification of signal options and signal thresholds also extend the range of possible applications.

The power supply is configured via the device's internal NFC (near field communication) interface. This is located behind the QR code on the front.

 The power supply behaves like a passive NFC tag. An auxiliary power source is required in order to supply the power supply with configuration data.

### 12.1 Configuration with PC software

In order to configure the power supply via the NFC interface, the following hardware and software requirements must be met:

- PC or notebook (as of Windows 7, Microsoft.Net Framework 4.5, USB 2.0 interface, 50 MB hard disk capacity, QUINT POWER software).
- Programming adapter: TWN4 MIFARE NFC USB ADAPTER (Item No. 2909681) is plugged into the USB interface.
- Programming software: the QUINT POWER software has been successfully installed.

### 12.2 Configuring the power supply

To configure the power supply, proceed as follows:

- Before you can configure the power supply, it should either be disconnected from the supply voltage or switched to SLEEP MODE.
- To switch the power supply to SLEEP MODE, use one of the external circuits. The following connection versions are possible between the Rem (remote input) and SGnd (signal ground) connection terminal blocks.

Figure 23 SLEEP MODE connection versions

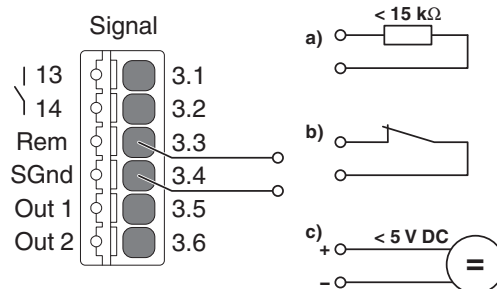

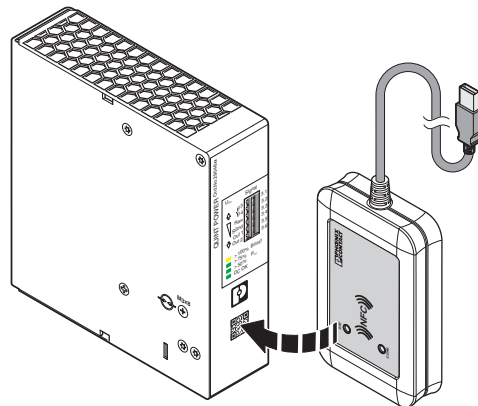

- Hold the USB-PROG-ADAPTER in front of the mounted power supply such that the NFC antenna symbol is over the QR code.

Figure 24 Configuration of the power supply



- In the programming interface of the QUINT POWER software, press the [Read] button. The current device and configuration data for the power supply is read and displayed.

 If a connection cannot be established between the USB-PROG-ADAPTER and the power supply, more detailed information can be found in the user manual for the QUINT POWER software.

 For information regarding the configuration of the power supply, such as selecting the characteristic curve and output parameters, refer to the user manual for the QUINT POWER software.

### 12.3 Configuration with NFC-capable mobile terminal device

The QUINT POWER app enables you to conveniently configure the power supply using a mobile terminal device, such as a smartphone.

In order to configure the power supply via the NFC interface, the following hardware and software requirements must be met:

- NFC-capable mobile terminal device with Android operating system as of Version 4.1.x (Jelly Bean)
- QUINT POWER app (Google Play Store)



For information regarding the configuration of the power supply, such as selecting the characteristic curve and output parameters, please refer to the QUINT POWER app.

### 12.4 Ordering a configured power supply

Customer-specified QUINT POWER power supplies are ordered as a KMAT item (configurable material) and are configured during the production process in the factory. The power supply is therefore supplied ready to connect for your specific application.



You can type in the the web code [phoenixcontact.net/webcode/#0852](http://phoenixcontact.net/webcode/#0852) to configure and order your power supply.

## 13 Boost currents

The power supply provides the static boost ( $I_{Stat. Boost}$ ) for a sustained load supply or the time-limited dynamic boost ( $I_{Dyn. Boost}$ ).

### 13.1 Static Boost

For system expansion purposes, the sustained static boost ( $I_{Stat. Boost}$ ) supports the load supply with up to 125 % of the nominal current of the power supply. The static boost is available at an ambient temperature of up to 40 °C.

Figure 25 Performance characteristic in static boost

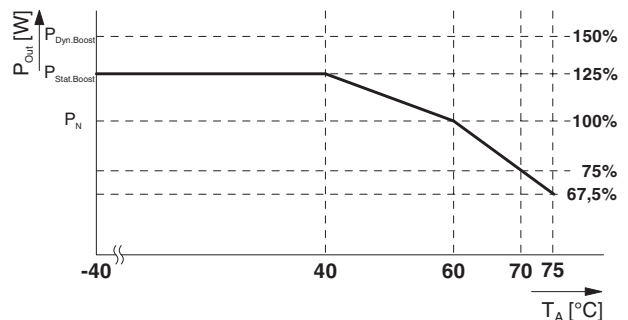

### 13.2 Dynamic Boost

Dynamic boost ( $I_{Dyn. Boost}$ ) delivers up to 150 % of the power supply nominal current to supply high loads. This temporary power supply to the load lasts a maximum of 5 s at an ambient temperature of up to 60 °C. The energy supplied adaptively for the load supply and the recovery time ( $t_{Pause}$ ) are calculated based on the specific load situation using algorithms (see recovery time tables).

Figure 26 Basic curve of the dynamic boost process

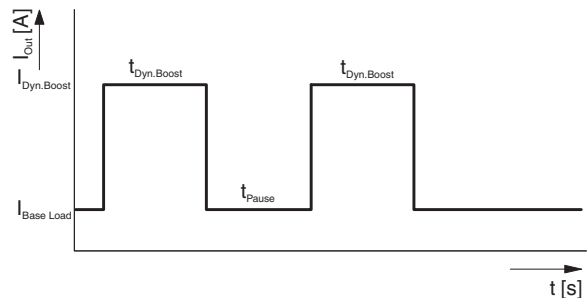

Use the following tables to determine the required recovery time ( $t_{\text{Pause}}$ ) at the maximum dynamic boost current ( $I_{\text{Dyn. Boost}}$ ) based on the following values:

- $I_{\text{Base Load}}$
- Duration of the boost current ( $t_{\text{Dyn. Boost}}$ )
- Ambient temperature (40 °C or 60 °C)



If a current that is lower than the maximum available dynamic boost current ( $I_{\text{Dyn. Boost}}$ ) is required for the same period, the recovery time may ( $t_{\text{Pause}}$ ) decrease.

**13.2.1 Recovery times at an ambient temperature of 40 °C**

Figure 27 Required recovery times at ≤ 40°C

$I_{\text{Base Load}}$ [A]	$I_{\text{Dyn. Boost}}$ [A]	$t_{\text{Dyn. Boost}}$ [s]					$t_{\text{Pause}}$ [s]
		1	2	3	4	5	
0	30	0,2	0,4	0,6	0,8	1	
5	30	0,2	0,5	0,7	1	1,2	
10	30	0,3	0,6	0,9	1,2	1,5	
15	30	0,4	0,8	1,2	1,6	2,1	
20	30	0,7	1,4	2,1	2,8	3,5	
25	30	3,4	7	11	14	17	

**13.2.3 Example: Determining the recovery time ( $t_{\text{Pause}}$ )**

At an output current ( $I_{\text{Base Load}}$ ) of 10 A, the dynamic output current ( $I_{\text{Dyn. Boost}}$ ) of 30 A increases for 2 s ( $t_{\text{Dyn. Boost}}$ ). After a recovery time ( $t_{\text{Pause}}$ ) of 0.6 s, the dynamic boost is available once again.

Figure 29 Example recovery time for ≤ 40°C

$I_{\text{Base Load}}$ [A]	$I_{\text{Dyn. Boost}}$ [A]	$t_{\text{Dyn. Boost}}$ [s]					$t_{\text{Pause}}$ [s]
		1	2	3	4	5	
0	30	0,2	0,4	0,6	0,8	1	
5	30	0,2	0,5	0,7	1	1,2	
10	30	0,3	0,6	0,9	1,2	1,5	
15	30	0,4	0,8	1,2	1,6	2,1	
20	30	0,7	1,4	2,1	2,8	3,5	
25	30	3,4	7	11	14	17	

**13.2.2 Recovery times at an ambient temperature of 60 °C**

Figure 28 Required recovery times at ≤ 60°C

$I_{\text{Base Load}}$ [A]	$I_{\text{Dyn. Boost}}$ [A]	$t_{\text{Dyn. Boost}}$ [s]					$t_{\text{Pause}}$ [s]
		1	2	3	4	5	
0	30	0,4	0,9	1,3	1,7	2,1	
5	30	0,6	1,3	1,9	2,5	3,1	
10	30	1	2	3	4	4,9	
15	30	1,9	3,7	6	8	10	
20	30	13	26	38	51	63	



## 14 SFB Technology

SFB Technology (selective fuse breaking) can be used to quickly and reliably trip miniature circuit breakers and fuses connected on the secondary side. In the event of a short circuit on the secondary side, the power supply supplies up to 6 times the nominal current for 15 ms. The faulty current path is switched off selectively.

Loads that are connected in parallel are still supplied with energy. Operation of these system parts is ensured. In order to always enable the reliable tripping of circuit breakers and fuses, certain framework conditions must be observed (see SFB configuration section).



The U/I Advanced output characteristic curve supports SFB Technology.

### 14.1 Tripping circuit breakers

The circuit breaker is tripped by the high SFB current of the power supply, typically within 3 to 5 ms. As a result, voltage dips at loads that are connected in parallel are avoided.

Figure 30 SFB pulse trips circuit breakers

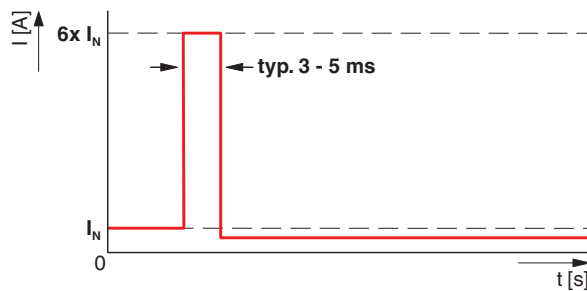

### 14.2 Tripping a fuse

Fuses are tripped by melting the predetermined breaking point inside the fuse capsule. The tripping characteristic of the fuse is described by the melting integral ( $I^2t$ ). A high current is crucial in order to achieve a very short tripping time.

### 14.3 SFB configuration

Observe the following framework conditions for determining the maximum distance between the power supply and load:

- The performance class of the power supply
- The cross section of the connecting cable
- The tripping characteristic of the fuse component

Figure 31 Schematic diagram of the maximum cable length

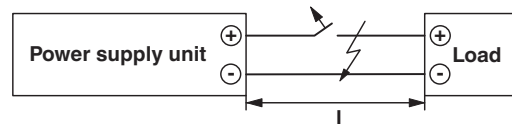

**14.4 Maximum distance between the power supply and load**

The distances given in the table are worst-case values and therefore cover the entire tolerance range for the magnetic tripping of circuit breakers. The possible distances are often greater in practice.

**14.4.1 Thermomagnetic device circuit breaker, type: Phoenix Contact CB TM1 SFB**

Maximum distance l [m] with device circuit breaker		Conductor cross section						
		A [mm <sup>2</sup> ]	0.75	1.0	1.5	2.5	4.0	6.0
		AWG	18	(17)	16	14	12	10
Phoenix Contact	CB TM1 1A SFB P		27	36	54	91	< 130	< 200
	CB TM1 2A SFB P		18	25	37	63	< 100	< 140
	CB TM1 3A SFB P		13	18	27	46	73	< 100
	CB TM1 4A SFB P		10	14	21	35	57	86
	CB TM1 5A SFB P		8	11	17	29	46	70
	CB TM1 6A SFB P		6	8	12	20	32	48
	CB TM1 8A SFB P		--	5	7	12	20	30
	CB TM1 10A SFB P		--	3	4	8	13	19

The cable lengths determined are based on the following parameters:

- Tripping: magnetic
- DC correction factor (0 Hz): Phoenix Contact = 1,0
- Characteristics: C  
Characteristic C (10 times the rated current) x correction factor
- Ambient temperature: +20 °C
- Internal resistance R<sub>i</sub> of the device circuit breaker: taken into consideration
- Comments: In addition to the short-circuit current, the power supply unit also supplies half the nominal current for load paths connected in parallel.

14.4.2 Thermomagnetic circuit breaker, type: Siemens 5SY, ABB S200

Maximum distance l [m] with circuit breaker		Conductor cross section						
		A [mm <sup>2</sup> ]	0.75	1.0	1.5	2.5	4.0	6.0
		AWG	18	(17)	16	14	12	10
Siemens 5SY	A1		78	105	157	263	420	631
	A1.6		58	77	116	194	311	467
	A2		49	65	98	164	262	394
	A3		35	47	71	118	190	285
	A4		27	36	54	90	144	217
	A6		18	25	37	62	100	150
	A8		14	19	28	48	76	115
	A10		11	15	23	38	61	92
	A13		8	11	16	27	44	66
	A16		5	7	11	18	30	45
	B2		28	37	56	93	149	224
	B4		16	21	32	53	85	128
	B6		10	14	21	36	57	86
	B10		5	6	10	17	27	41
	B13		3	4	6	10	16	24
	C1		10	14	21	35	56	84
	C1.6		12	17	25	42	68	102
	C2		11	15	23	39	62	94
	C3		9	12	18	30	48	72
	C4		6	8	12	21	34	51
C6		2	3	5	9	15	23	
C8		12	17	25	42	68	102	
ABB S200	B6		10	13	20	33	53	80
	B8		6	9	13	22	36	55
	B10		4	5	8	14	23	35
	B13		2	3	5	8	13	20
	C1		3	4	6	11	17	26
	C1.6		7	10	15	25	41	62
	C2		7	9	14	23	38	57
	C3		8	10	16	26	42	64
	C4		4	6	9	16	26	39
	C6		2	2	4	7	11	17
	Z1		64	85	128	214	343	514
	Z1.6		46	62	93	156	250	375
	Z2		42	57	85	143	229	343
	Z3		33	44	66	110	176	264
	Z4		24	33	49	82	132	198
	Z6		16	21	32	54	87	131
Z10		10	14	21	36	57	86	
Z16		4	6	9	16	26	39	

The cable lengths determined are based on the following parameters:

Tripping:	magnetic
DC correction factor (0 Hz):	Siemens = 1.4; ABB = 1.5
Characteristics:	A, B, C, Z Characteristic A (3 times the rated current) x correction factor Characteristic B (5 times the rated current) x correction factor Characteristic C (10 times the rated current) x correction factor Characteristic Z (3 times the rated current) x correction factor
Ambient temperature:	+20 °C
Internal resistance $R_i$ of the device circuit breaker:	taken into consideration
Comments:	In addition to the short-circuit current, the power supply unit also supplies half the nominal current for load paths connected in parallel.

14.4.3 Fuse, type: Cooper Bussmann GMA xA, GMC xA

Maximum distance l [m] with fuse		Melting integral I <sup>2</sup> t [A <sup>2</sup> s]	Conductor cross section						
			A [mm <sup>2</sup> ]	0.75	1.0	1.5	2.5	4.0	6.0
		AWG	18	(17)	16	14	12	10	
Cooper Bussmann	GMA 1A	0.48	48	64	97	162	259	389	
	GMA 1.25A	0.84	36	49	73	122	196	294	
	GMA 1.5A	1.6	26	35	53	88	142	212	
	GMA 1.6A	2	23	31	47	79	127	190	
	GMA 2A	3.1	19	25	38	63	101	152	
	GMA 2,5A	4.9	15	20	30	51	81	122	
	GMA 3A	8.8	11	15	22	37	60	90	
	GMA 3,15A	9.7	10	14	21	36	57	86	
	GMA 3,5A	13	9	12	18	31	49	74	
	GMA 4A	19	6	8	12	21	34	51	
	GMA 5A	29	4	5	8	14	22	34	
	GMC 1A	1.8	23	31	47	78	125	188	
	GMC 1,25A	3.4	17	23	34	58	93	140	
	GMC 1,5A	5.4	13	18	27	46	74	111	
	GMC 1,6A	5.8	13	18	27	45	72	108	
	GMC 2A	8.9	11	14	22	37	59	89	
	GMC 2.5A	13	9	12	18	30	49	73	
	GMC 3A	19	6	8	12	21	34	51	
	GMC 3,15A	23	5	7	10	17	28	42	
	GMC 3,5A	25	4	6	9	16	26	39	
GMC 4A	36	3	4	6	11	18	27		

The cable lengths determined are based on the following parameters:

- Tripping: thermal
- Characteristics: Cooper Bussmann GMA (fast-blow - fast acting)  
Cooper Bussmann GMC (medium-blow - medium time delay)
- Ambient temperature: +20 °C
- Internal resistance R<sub>i</sub> of the fuse: taken into consideration
- Comments: In addition to the short-circuit current, the power supply unit also supplies half the nominal current for load paths connected in parallel.

## 15 Signaling

A floating signal contact and two digital outputs are available for preventive function monitoring of the power supply. Depending on the configuration of the power supply, either the two digital outputs or one digital and one analog output can be selected. The signal outputs are electrically isolated from the input and output of the power supply.

The current device status of the power supply is signaled using four LED status indicators. The function of each LED status indicator is assigned to a fixed event.

In addition, the power supply can be switched off and on via an external circuit.

The signal outputs are configured on the software side using the QUINT POWER software or the QUINT POWER app. Upon delivery, the power supply is pre-allocated a default configuration for the signal outputs.

 The reference potential SGnd (Signal Ground) must be used for signal outputs.

### 15.1 Location and function of the signaling elements

Figure 32 Position of signaling elements

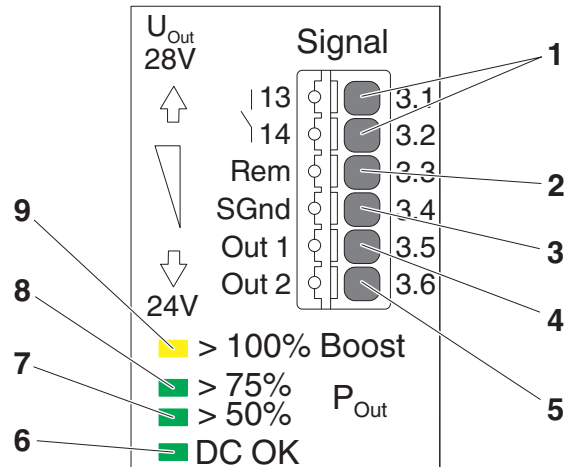

#### Key

No.	Signaling elements
1	13/14 floating switch contact (N/O contact)
2	Rem, remote input (switch power supply off and on)
3	SGnd, signal ground (reference potential for signals Out 1, Out 2)
4	Out 1 (digital output, function depends on the signal option set)
5	Out 2 (digital or analog output, function depends on the signal option set)
6	LED status indicator DC OK
	LED on: $U_{Out} > 90\% \times U_{Set}$
	LED flashing: $U_{Out} < 90\% \times U_{Set}$
7	LED status indicator P <sub>Out</sub> > 50 % (output power > 240 W)
8	LED status indicator P <sub>Out</sub> > 75 % (output power > 360 W)
9	LED status indicator P <sub>Out</sub> > 100 %, boost mode (output power > 480 W)

### 15.1.1 Floating signal contact

In the default configuration, the floating switch contact opens to indicate that the set output voltage has been undershot by more than 10 % ( $U_{Out} < 0.9 \times U_N$ ). Signals and ohmic loads can be switched. For heavily inductive loads (e. g. a relay), a suitable protective circuit (e. g. a freewheeling diode) is necessary.

Figure 33 Signaling

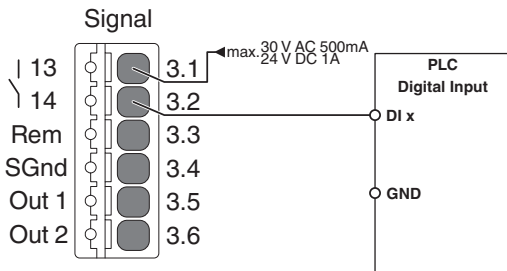

### 15.1.2 Active signal outputs, digital

Signals are forwarded to the higher-level controller via the "Out 1" and "Out 2" signal outputs.

The 24 V DC signal is applied between the connection terminal blocks "Out 1" and "SGnd" or between "OUT 2" and "SGnd". It can carry a maximum of 20 mA.

By switching from "Active High" to "Active Low", the signal output "Out 1" indicates that the set output voltage has been undershot by more than 10 % ( $U_{OUT} < 0.9 \times U_N$ ).

In the default configuration, the signal output "Out 2" indicates that the nominal power has been exceeded. The power supply then switches to boost mode. Thanks to this preventive function monitoring, critical operating states can be recognized at an early stage, prior to a voltage dip occurring.

Figure 34 Signaling

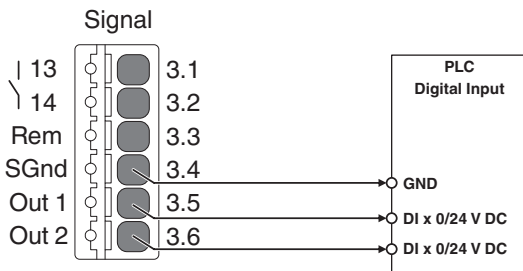

### 15.1.3 Active analog signal output

The signal output "Out 2" can be used as an analog signal output to continuously monitor the device workload.

The 4 ... 20 mA signal is applied between the connection terminal blocks "Out 2" and "SGnd". It is proportional to the set signaling parameter.

Figure 35 Signaling

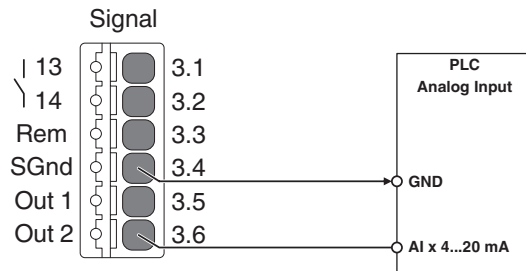

If you use the same reference potential for 24 V supply and signals, wire the reference potential SGnd to the reference potential of your application.

The signal outputs of the power supply are electrically isolated from the input and output.

### 15.2 Preventive function monitoring

In contrast to the default signaling set upon delivery, you can customize this to the specific needs of the system. The following signal options can be selected to signal system states.

QUINT POWER default settings upon delivery			Out 1 digital 0/24 V DC 20 mA	Out 2 digital 0/24 V DC 20 mA	Relay 13/14 floating 24 V DC / ≤ 1 A 30 V AC / ≤ 0.5 A	Out 2 analog 4 ... 20 mA
	Output voltage	① 25 ... 135 % ② 90 %	Default	✓	Default	① 0 ... 30 A ② 0 ... 30 A
	Output current	① 5 ... 150 % ② 100 %	✓	✓	✓	① 0 ... 30 A ② 0 ... 20 A
	Output power	① 5 ... 150 % ② 100 %	✓	Default	✓	① 0 ... 720 W ② 0 ... 480 W
	Operating hours	① 0 ... ∞ h ② 10 years	✓	✓	✓	--
	Early warning of high temperature	Warning of derating	✓	✓	✓	--
<b>OVP</b>	Voltage limitation active	Surge voltage at output	✓	✓	✓	--
<b>AC<sub>OK</sub></b>	Input voltage OK	10 ms after mains failure	✓	--	✓	--

#### Key

Symbol	Description
①	Setting range
②	Default setting of the standard item
Default	Configuration set upon delivery
✓	Configuration that can be selected
--	Configuration that cannot be selected

The simultaneous control of multiple signal outputs by means of one signal option is possible, as is the use of logic operations to link multiple signal options to one control. The power supply is configured using the QUINT POWER software or the QUINT POWER app.



### 15.3 Description of signaling

#### 15.3.1 Output voltage

Signals whether the output voltage is in the preset range. If the output voltage of the power supply falls below the set threshold value, the signal state changes.

##### Example of use

Indicates whether the connected load is being supplied. Used to quickly detect a load circuit that is not being supplied (e.g., in the event of mains failure or short circuit in the supply line).

#### 15.3.2 Output current

If the output current of the power supply exceeds the set threshold value, the signal state changes.

##### Example of use

In the case of system extensions, loads are added. This increases the utilization of the power supply. Preventive function monitoring detects critical operating states in good time. Action can be taken before system downtime occurs.

#### 15.3.3 Output power

If the output power of the power supply exceeds the set threshold value, the signal state changes.

##### Example of use

In the case of system extensions, loads are added. This increases the utilization of the power supply. Preventive function monitoring detects critical operating states in good time. Action can be taken before system downtime occurs.

#### 15.3.4 Operating hours

If the preset operating time of the power supply is exceeded, the signal state changes.

##### Example of use

For systems with a very long operating time, such as wind turbine generators or refineries, maintenance intervals are planned. You can even schedule the maintenance date during configuration based on the ambient temperature and utilization of the power supply.

#### 15.3.5 Early warning of high temperature

Before the power supply protects itself through power derating in the event of an overtemperature, the signal state changes.

#### Example of use

Outdoor control cabinets can reach a high internal temperature depending on the position of the sun. The same is true if a control cabinet fan or cooling system fails. In the event of any form of overtemperature, the power supply provides a warning by means of this signal, well before the supply of the loads is in any danger.

Specifications regarding the available output power (see derating section).

#### 15.3.6 Voltage limitation active

If the circuit inside the device for protecting against surge voltages is activated at the output, the signal state changes.

#### Example of use

Normative requirements stipulate that an upper voltage limit must be observed at the output in the event of an error. It must therefore be ensured, for example, that safety-related controllers are not supplied with an output voltage that exceeds 30 V DC, even in the event of an error. If foreign bodies (ferrules, screws, etc.) enter the power supply and generate an error, the signal state changes.

#### 15.3.7 Input voltage OK

The power supply signals a mains failure at least 10 ms before shutting off.

#### Example of use

In the event of a mains failure, the power supply continues to supply the load with nominal power for at least 20 ms. Failure of the input voltage is signaled 10 ms before the output voltage falls, which means that this information is provided to the higher-level controller at an early stage. System states can therefore be stored promptly without any loss of data as a result of the unexpected failure of the supply voltage.

### 15.4 Remote input

The power supply is switched on and off using the digital remote input of the power supply. When switched off, power transmission is deactivated on the DC output side of the power supply. The load connected to the DC output terminal blocks is no longer supplied with energy. The operating mode where the DC output side is deactivated is called SLEEP MODE.

To switch the power supply to SLEEP MODE, select one of the external circuit versions below. The external circuit is wired between signal terminal blocks Rem (remote input) and SGnd (signal ground).

Figure 36 External wiring versions, enable SLEEP MODE

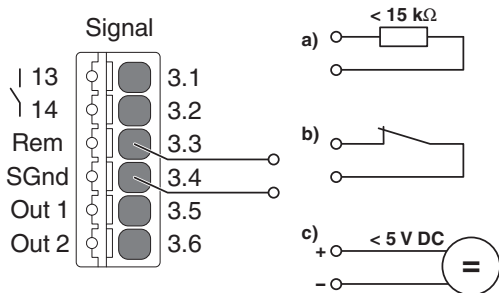

To switch the power supply back on, select one of the following external circuits between signal terminal blocks Rem and SGnd. Power transmission inside the device is activated again. As usual, the energy for supplying the loads is available at the DC output terminal blocks.

Figure 37 External wiring versions, disable SLEEP MODE

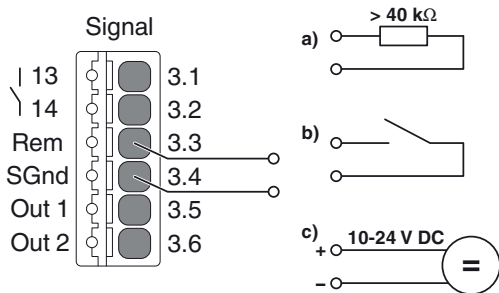

When using a PLC output, select the following external circuit version to switch the power supply to SLEEP MODE.

Figure 38 External wiring versions with PNP and NPN output

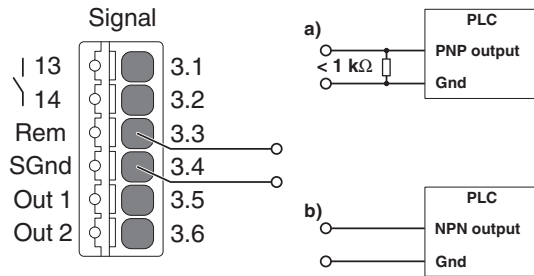

### 15.5 LED status indicators

Four LED status indicators are integrated in the front of the power supply, which indicate the current device state.













The green DC OK LED indicates the current status of the output voltage ( $U_{Out}$ ). The DC OK LED is permanently on as long as the value of the output voltage  $U_{Out}$  is  $\geq 0.9 \times U_{Set}$ . If the value of the output voltage is  $< 0.9 \times U_{Set}$ , the green DC OK LED flashes.

Depending on the required output power of the connected load, the three  $P_{Out}$  LEDs, which indicate the current output power, light up. Assuming that the provided output power is  $> 50\%$  of the nominal output power, the  $> 50\%$  LED lights up green. If the demanded power continues to increase until it is above  $75\%$ , the  $> 75\%$  LED lights up green in addition to the  $> 50\%$  LED. If the required output power is then greater than the nominal device power, the power supply operates in boost mode. In boost mode, the  $> 100\%$  LED additionally lights up yellow.

### 15.6 U/I Advanced characteristic curve signaling

The following table shows the standard assignment for signaling for the U/I Advanced characteristic curves which is set by default.

Figure 39 Signal image for U/I Advanced













		Normal operation $P_{Out} < P_N$	BOOST $P_{Out} > P_N$	Overload operation $U_{Out} < 0.9 \times U_{Set}$
LED: $P_{Out} > 100\%$	yellow			
Signal Out 2: $P_{Out} < P_N$	Default	Active High	Active Low	Active Low
LED: $P_{Out} > 75\%$	green			
LED: $P_{Out} > 50\%$				
LED: DC OK				
Relay: 13/14, DC OK	Default	closed	closed	open
Signal Out 1: DC OK		Active High	Active High	Active Low



### 15.7 Smart HICCUP characteristic curve signaling

The following table shows the standard assignment for signaling for the Smart HICCUP characteristic curve.

Figure 40 Signal image for Smart HICCUP

		Normal operation $P_{Out} < P_N$	BOOST $P_{Out} > P_N$	Overload operation $U_{Out} < 0.9 \times U_{Set}$
LED: $P_{Out} > 100\%$	Yellow			
Signal Out 2: $P_{Out} < P_N$	Default	Active High	Active Low	Active Low
LED: $P_{Out} > 75\%$	Green			
LED: $P_{Out} > 50\%$				
LED: DC OK				
Relay: 13/14, DC OK	Default	Closed	Closed	Open
Signal Out 1: DC OK		Active High	Active High	Active Low



**15.8 FUSE MODE characteristic curve signaling**

The following table shows the standard assignment for signaling for the FUSE MODE characteristic curve.

Figure 41 Signal image for FUSE MODE

		Normal operation $P_{Out} < P_N$	BOOST $P_{Out} > P_N$	FUSE MODE $I > I_{Fuse}$ for $t > t_{Fuse}$
LED: $P_{Out} > 100\%$	Yellow			
Signal Out 2: $P_{Out} < P_N$	Default	Active High	Active Low	Active Low
LED: $P_{Out} > 75\%$	Green			
LED: $P_{Out} > 50\%$				
LED: DC OK				
Relay: 13/14, DC OK	Default	Closed	Closed	Open
Signal Out 1: DC OK		Active High	Active High	Active Low



**15.9 SLEEP MODE signaling**

In SLEEP MODE, all LEDs are off, all signals are low, and the relay switching contact is open.

## 15.10 Special immunity for the signal level

### 15.10.1 Surge protection for the high-voltage area at the power plant

Surge protection (Phoenix Contact Item No.: 2907925 or comparable protection) must be implemented for power plant applications when using signal connection types t (telecommunications area), h (high voltage area) or f (field) in accordance with IEC/EN 61850-3 or signal connection types 3 (process area) and 4 (high voltage area) in accordance with EN 61000-6-5.

When using the digital signals, a relay (Phoenix Contact Item No.: 2900299 or a comparable relay) can be implemented.

### 15.10.2 Surge protection for signals in railway applications

Surge protection (Phoenix Contact Item No.: 2907925 or comparable protection) must be implemented for railway applications when using signals in accordance with EN 62236-4 and EN 50121-4.

When using the digital signals, a relay (Phoenix Contact Item No.: 2900299 or a comparable relay) can be implemented.

### 15.10.3 Surge protection for devices in use in safety-related systems

Surge protection (Phoenix Contact Item No.: 2907925 or comparable protection) must be implemented for railway applications when using signals in accordance with EN 61000-6-7 for devices provided to perform functions in safety-related systems (functional safety) in industrial settings.

When using the digital signals, a relay (Phoenix Contact Item No.: 2900299 or a comparable relay) can be implemented.

Figure 42 Schematic diagram, signal wiring with TRABTECH surge protection

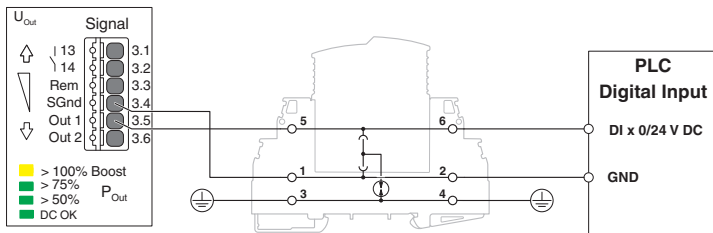
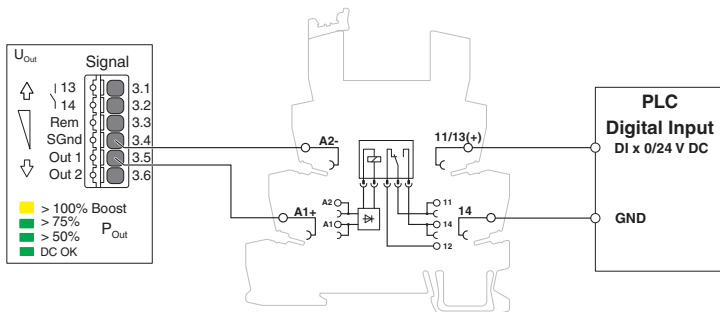

Figure 43 Schematic diagram, signal wiring with relay module



## 16 Operating modes

### 16.1 Series operation

To double the output voltage, connect two power supplies in series. Only use power supplies with the same performance class and configuration for series operation. If two 24 V DC power supplies are connected in series, an output voltage of 48 V DC is available to supply the loads.

Figure 44 Schematic diagrams in series operation

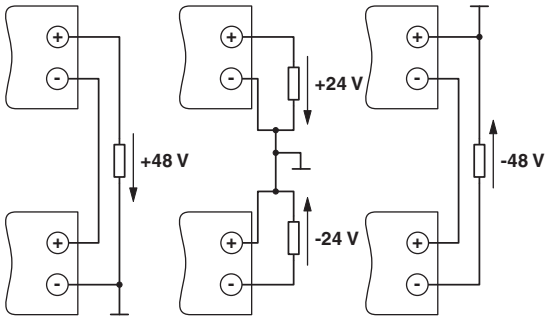

### 16.2 Parallel operation

You can connect several power supplies in parallel in order to increase the power or to supply the loads redundantly.

Figure 45 Schematic diagram in parallel operation

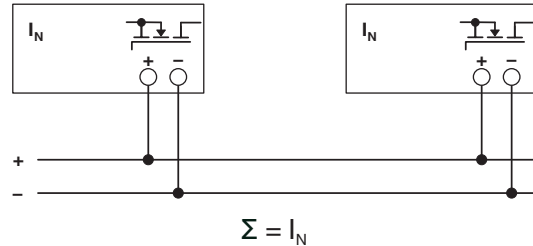

Observe the following points when carrying out parallel connection:

1. Use power supplies of the same type and performance class
2. Setting the same output voltages
3. Using the same cable cross sections for wiring
4. Using the same cable lengths for the DC convergence point
5. Operating power supplies in the same temperature environment



We recommend the configuration "parallel operation" for a parallel connection. For more detailed information on the operating mode for parallel operation, refer to the user manual for the QUINT POWER software or the QUINT POWER app.

### 16.2.1 Redundancy operation

Redundant circuits are suitable for supplying systems and system parts which place particularly high demands on operational reliability.

If energy is to be supplied to the load with 1+1 redundancy, two power supplies of the same type and performance class must be used. In the event of an error, it must be ensured that one of the power supplies is able to provide the total required power for the load. This means that in redundancy mode, two 20 A power supplies supply a load with a nominal current of 20 A, for example. During normal operation of the power supplies, each power supply therefore supplies 10 A. Always use cables with the same cross sections and lengths when wiring the power supplies on the DC output side.

QUINT POWER power supplies with integrated decoupling MOSFET can be used for 1+1 and n+1 redundancies. The power supplies are up to 100 % decoupled from each other. They ensure the supply in case of error.

Figure 46 Schematic diagram, 1+1 redundant operation for 20 A output current

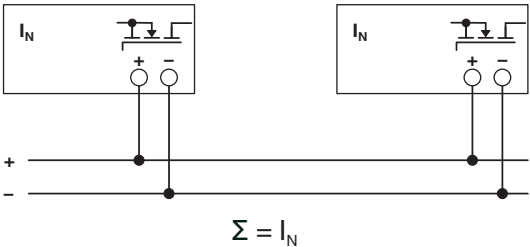
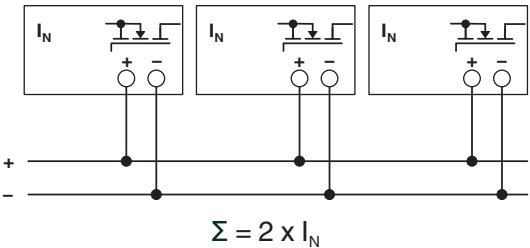

Figure 47 Schematic diagram, n+1 redundant operation for 40 A output current



Certain specifications apply in redundancy operation with regard to the configuration of the keepout areas. In redundancy operation, the power supplies are operated with maximum half the nominal power. The keepout areas are therefore reduced.

Using the signaling settings, you can monitor whether both power supplies are being operated with the same nominal load. In the case of system extension, an overload is prevented if one of the power supplies fails.

### 16.2.2 Increased power

When n power supplies are connected in parallel, the output current is increased to  $n \times I_N$ . Parallel connection for increased power is used when extending existing systems. If the individual power supply does not cover the current consumption of the most powerful load, parallel connection of power supplies is recommended.

Figure 48 Schematic diagram of increased performance

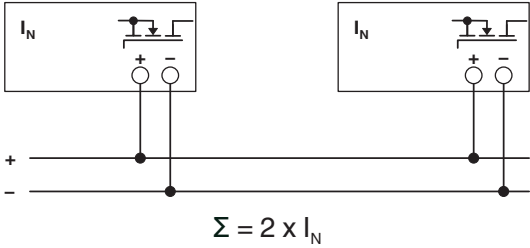

## 17 Derating

The QUINT POWER power supply runs in nominal operation without any limitations. For operation outside the nominal range, the following points should be observed depending on the type of use.

### 17.1 Ambient temperature

When operating the power supply at an ambient temperature of  $> 60\text{ °C}$ , a power derating of  $2.5\text{ %/K}$  should be observed. Up to an ambient temperature of  $40\text{ °C}$ , the power supply can take power from the static boost for a sustained period. In the  $40\text{ °C}$  to  $60\text{ °C}$  temperature range, the power supply can output more than the nominal power for a sustained period.

Figure 49 Output power depending on the ambient temperature

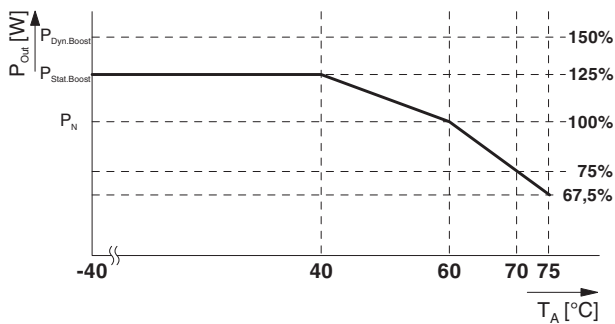

### 17.2 Input voltage

Derating 1 %/V			
$U_{In}$	$\vartheta_A$	$I_{Out}$	$U_{Out}$
< 100 V AC	$\leq 60\text{ °C}$	$I_N$	24 V DC
< 110 V DC			
< 115 V AC	$\leq 40\text{ °C}$	$I_{Stat. Boost}$	
< 110 V DC			

### 17.3 Installation height

The power supply can be operated at an installation height of up to 2000 m without any limitations. Different data applies for installation locations above 2000 m due to the differing air pressure and the reduced convection cooling associated with this (see technical data section). The data provided is based on the results of pressure chamber testing performed by an accredited test laboratory.

Figure 50 Output power depending on the installation height

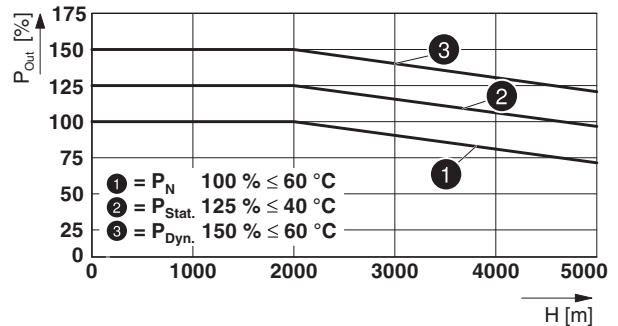



**17.4 Position-dependent derating**

The fanless convection-cooled power supply can be snapped onto all DIN rails in accordance with EN 60715.



The power supply should be mounted horizontally for heat dissipation reasons (AC connection terminal blocks facing downward). Please observe the derating for any mounting other than the normal mounting position. Reduce the output power based on the prevailing ambient temperature.

The recommended output power for different mounting positions and ambient temperatures can be found in the characteristic curves below.

Exceeding these values will reduce the service life of the power supply.

**17.4.1 Normal mounting position**

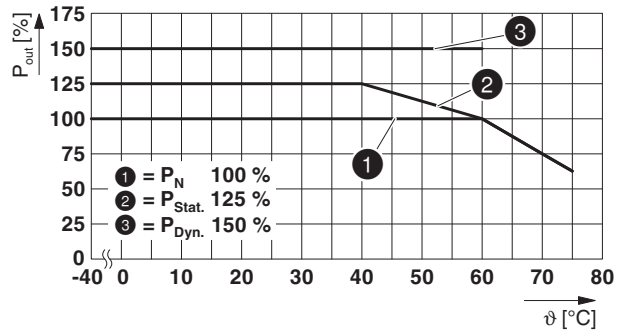
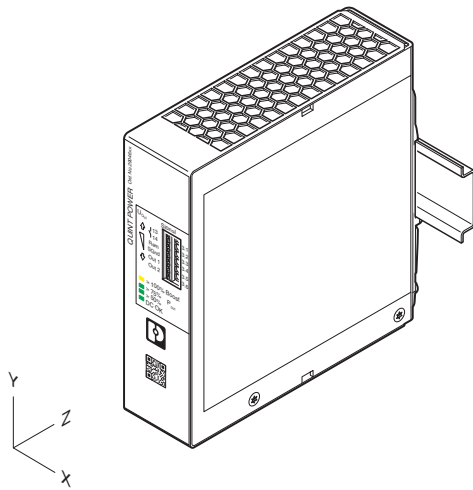

**17.4.2 Rotated mounting position 90° Z-axis**

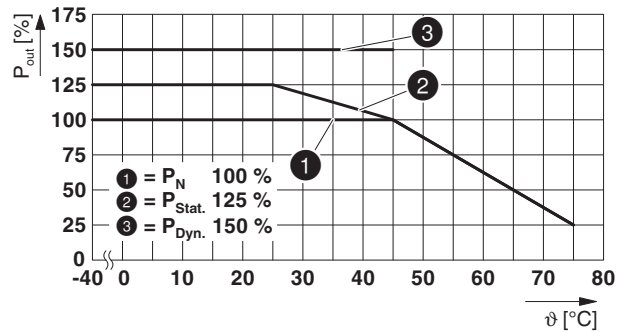
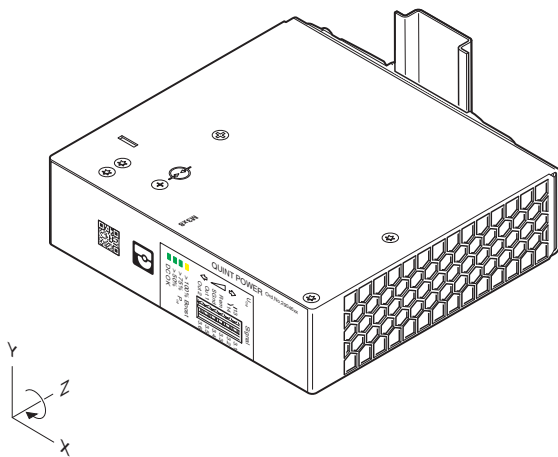

17.4.3 Rotated mounting position 180° Z-axis

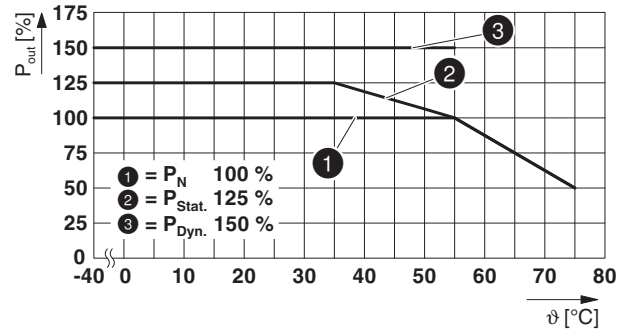
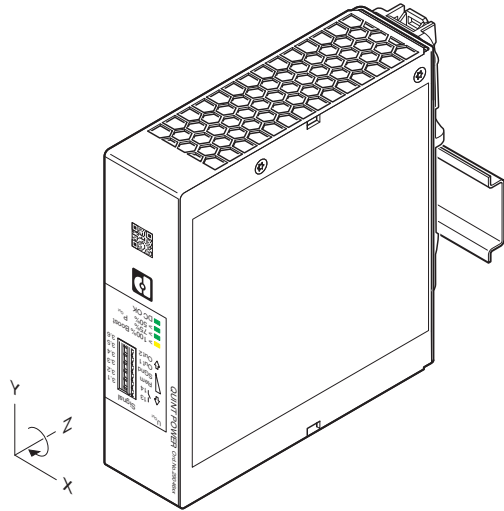

17.4.4 Rotated mounting position 270° Z-axis

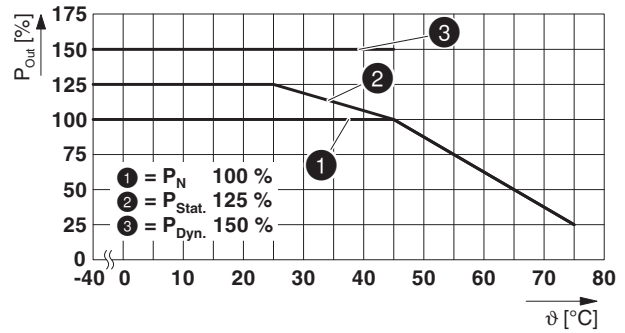
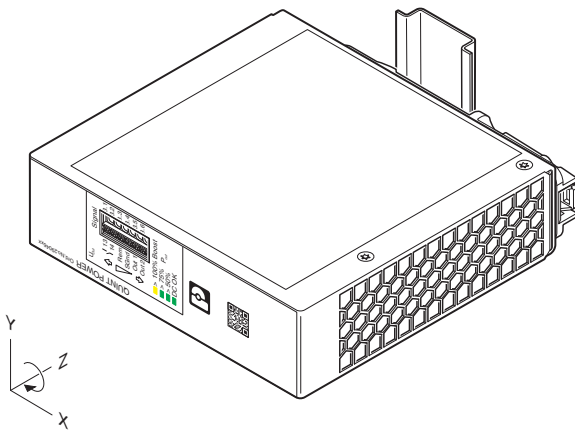

17.4.5 Rotated mounting position 90° X-axis

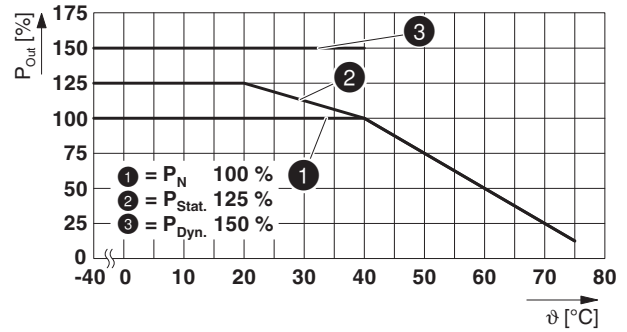
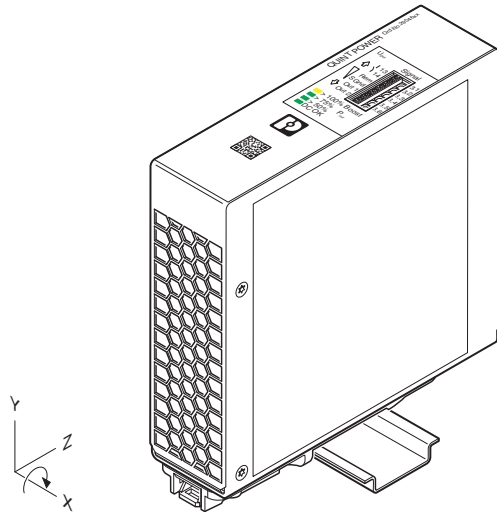

17.4.6 Rotated mounting position 270° X-axis

