

TRIO3-PS/1AC/24DC/20/CO

Power supply unit



Data sheet

111100_en_01

© Phoenix Contact

2024-04-15

1 Description

The power supplies in the TRIO POWER family are distinguished by their high power density along with their compact design in robust housing.

Critical supply situations during load startup and brief overload situations during operation are reliably managed thanks to the dynamic boost function ($1.5 \times I_N$ for min. 5 seconds).

The Push-in connection terminal block on the front enables fast and tool-free wiring of the power supply with rigid or flexible connecting cables with ferrules.

The TRIO POWER family now includes additional combined power supplies with 4 and 8-channel electronic circuit breakers with an additional IO-Link interface.

Features

- Space savings in the control cabinet due to the narrow design combined with increased performance (up to 100%)
- Worldwide use, thanks to AC and DC wide range input (1AC power supply) or AC wide range input (3AC power supply) with comprehensive international approval package
- Quick and easy startup with tool-free Push-in connection technology
- Visual and preventive function monitoring with multicolor LED and floating switch contact
- Flexible mounting by snapping onto a DIN rail or screwing onto a flat surface
- PCB with protective coating

Technical data (short form)

Input voltage range	100 V AC ... 240 V AC -15 % ... +10 % 100 V DC ... 240 V DC ± 10 % 115 V AC ... 240 V AC ± 10 % (UL) 160 V DC ... 240 V DC ± 10 % (UL)
Mains buffering time	typ. 23 ms (120 V AC) typ. 24 ms (230 V AC)
Nominal output voltage (U_N)	24 V DC
Setting range of the output voltage (U_{Set})	24 V DC ... 28 V DC
Output current I_N / $I_{Dyn.Boost}$	20 A / max. 30 A (5 s)
Output power P_N / $P_{Dyn.Boost}$	480 W / max. 720 W (5 s)
Efficiency (for nominal values)	typ. 93.8 % (120 V AC) typ. 95 % (230 V AC)
Residual ripple	typ. 50 mV _{PP}
MTBF (IEC 61709, SN 29500)	230 V AC / > 1400000 h (25 °C) 230 V AC / > 770000 h (40 °C) 230 V AC / > 310000 h (60 °C)
With protective coating	yes
Ambient temperature (operation)	-25 °C ... 70 °C (> 60 °C Derating: 2,5 %/K)
Startup type tested	-40 °C
Dimensions (W x H x D)	55 x 135 x 132 mm
Weight	940 g



All technical specifications are nominal and refer to a room temperature of 25 °C and 70 % relative humidity at 100 m above sea level.

2 Table of contents

1	Description	1
2	Table of contents	2
3	Ordering data	4
4	Technical data	5
5	Safety and installation notes	14
	5.1 Symbols used	14
	5.2 Safety and warning notes	14
	5.3 Intended use	15
6	High-voltage test (HIPOT)	16
	6.1 High-voltage dielectric test (dielectric strength test)	16
	6.2 High-voltage dielectric test during the manufacturing process	16
	6.3 High-voltage dielectric test performed by the customer	16
	6.3.1 Performing high-voltage testing	16
7	Structure	17
	7.1 Rating plate	17
	7.2 Connection terminal blocks and function elements	18
	7.3 Block diagram	19
	7.4 Dimensions	20
8	Mounting/remove	20
	8.1 Convection	20
	8.2 Mounting position	21
	8.3 Installation height	21
	8.4 Keep-out areas	21
	8.4.1 Variable keepout areas	21
	8.5 Mounting the power supply unit	22
	8.5.1 Mounting on the DIN rail (snap-on foot)	22
	8.6 Removing the power supply unit	22
	8.6.1 Removal from the DIN rail (snap-on foot)	22
	8.7 Retrofitting the universal DIN rail adapter (rotated by 90°, flat mounting position)	23
	8.7.1 Disassembling the universal DIN rail adapter	23
	8.7.2 Mounting the universal DIN rail adapter	23
	8.8 Retrofitting the UWA 182/52 mounting adapter	24
	8.8.1 Disassembling the universal DIN rail adapter	24
	8.8.2 Mounting the UWA 182/52 mounting adapter	24
	8.8.3 Fixing the UWA 182/52 mounting adapter with power supply to a mounting surface	25
9	Connection terminal blocks	25
	9.1 Push-in connection terminal blocks	25
	9.1.1 Wiring the Push-in connection terminal block	25
	9.1.2 Opening the Push-in connection terminal block	26

9.2	AC input terminal blocks	26
9.3	Primary-side fuse protection and connection.....	26
9.3.1	1AC supply network	27
9.3.2	3AC supply network (2-phase mode).....	27
9.3.3	DC supply network.....	27
9.4	DC output terminal blocks	27
9.4.1	Wiring principle for DC output terminals.....	28
9.4.2	Additional negative terminal	28
9.4.3	Protection of the secondary side.....	29
9.5	Floating switch contact.....	29
9.5.1	Wiring principle for the floating switch contact.....	29
9.6	Securing the connecting cables	30
10	Function elements.....	31
10.1	Operating element – potentiometer UOut	31
10.1.1	Sealing plug (optional)	31
10.2	Indication element – DC OK LED (multicolor LED)	32
11	Output characteristic curves.....	32
11.1	Normal operation/dynamic boost.....	33
11.1.1	Boost capability and recovery time	33
11.1.2	Example: Calculation of tBoost, tRecovery	34
11.2	U/I mode.....	34
11.3	HICCUP mode.....	34
12	Connection versions	35
12.1	Increasing power	35
12.1.1	Series operation.....	35
12.1.2	Parallel operation	35
12.2	Redundant operation.....	36
12.3	Fundamental prerequisites for parallel operation (power increase, redundancy operation)	36
13	Derating	37
13.1	Ambient temperature.....	37
13.2	Installation height	37
13.3	Position-dependent derating	38
13.3.1	Normal mounting position	38
13.3.2	Rotated mounting position 90° Z-axis	38
13.3.3	Rotated mounting position 180° Z-axis	39
13.3.4	Rotated mounting position 270° Z-axis	39
13.3.5	Rotated mounting position 90° X-axis	40
13.3.6	Rotated mounting position 270° X-axis	40
14	Disposal and recycling	41
15	Help with technical questions	41

3 Ordering data

Description	Type	Item no.	Pcs./Pkt.
Primary-switched power supply unit, TRIO POWER, Push-in connection, DIN rail mounting, input: 1-phase, output: 24 V DC / 20 A, adjustable from 24 V DC ... 28 V DC	TRIO3-PS/1AC/24DC/20/CO	1523020	1
Accessories			
Sealing plug for protection against manipulation (adjustment of the DC output voltage) by sealing off the potentiometer opening	POTI SEALING PLUG	1175957	50
Cable tie, transparent	WT-HF 3,6X140	3240744	100
Universal wall adapter for securely mounting the device in the event of strong vibrations. The device is screwed directly onto the mounting surface. The universal wall adapter is attached on the top/bottom.	UWA 182/52	2938235	1
Label, Roll, white, unlabeled, can be labeled with: THERMOMARK E.300 (D)/600 (D), THERMOMARK ROLL 2.0, THERMOMARK ROLL, THERMOMARK ROLL X1, THERMOMARK ROLLMASTER 300/600, THERMOMARK X1.2, mounting type: adhesive, lettering field size: 20 x 8 mm, Number of individual labels: 2500	EML (20X8)R	0816786	1
Label, Roll, yellow, unlabeled, can be labeled with: THERMOMARK E.300 (D)/600 (D), THERMOMARK ROLL 2.0, THERMOMARK ROLL, THERMOMARK ROLL X1, THERMOMARK ROLLMASTER 300/600, THERMOMARK X1.2, mounting type: adhesive, lettering field size: 20 x 8 mm, Number of individual labels: 2500	EML (20X8)R YE	0816799	1



You will find the latest accessories for the item at phoenixcontact.com/products.

4 Technical data

Input data



Unless otherwise stated, all data applies for 25°C ambient temperature, 230 V AC input voltage, and nominal output current (I_N).

Input voltage range	100 V AC ... 240 V AC -15 % ... +10 % 100 V DC ... 240 V DC ±10 % 115 V AC ... 240 V AC ±10 % (UL) 160 V DC ... 240 V DC ±10 % (UL)
Derating < 100 V AC / < 140 V DC	1 %/V / 1 %/V 2.5 %/K, > 60 °C
Frequency range (f_N)	50 Hz ... 60 Hz ±10 %
Typical national grid voltage	120 V AC / 230 V AC
Network type	Star network (TN, TT, IT (PE))
Current consumption 100 V AC / 240 V AC 120 V AC / 230 V AC 100 V DC / 240 V DC	5.3 A / 2.15 A 4.4 A / 2.3 A 5.2 A / 2.1 A
Discharge current to PE	< 3.5 mA
Mains buffering time 120 V AC / 230 V AC	typ. 23 ms / typ. 24 ms
Inrush current (25 °C)	< 21 A
Inrush current integral (I^2t)	< 1.091 A ² s
Device mains fuse , internal (device protection)	10 A



During the first few microseconds, the current flow into the filter capacitors is excluded.



The SCCR (short-circuit current rating) value of the power supply unit corresponds to the SCCR value of the backup fuse.

Input protection, AC (to be connected externally upstream)

Input current I_N Input protection	Circuit breaker					Neozed fuse or equivalent	Power switch $\leq 13 \times I_N$ (maximum magnetic tripping)
	A	B	C	D	K		
6 A	-	✓	✓	✓	✓	✓	✓
10 A	-	✓	✓	✓	✓	✓	✓
16 A	-	✓	✓	✓	✓	✓	✓
20 A	-	✓	✓	✓	✓	✓	✓

Protective circuit

Type of protection	Transient protection
Protective circuit/component	Varistor

Electric strength of the insulation

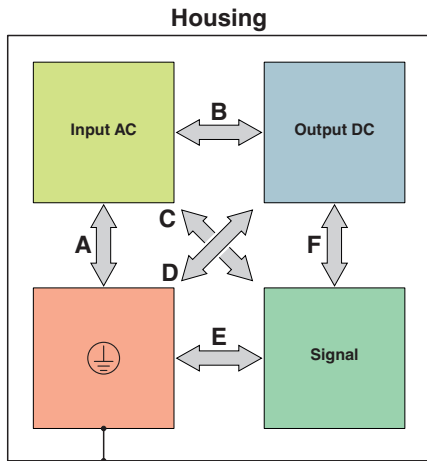

Test voltage	A	B	C	D	E	F
Type test (IEC/EN 61010-1)	3.3 kV DC	5.3 kV DC	5.3 kV DC	--	--	--
Production test	3.1 kV DC	3.1 kV DC	3.1 kV DC	--	--	--

POWER factor

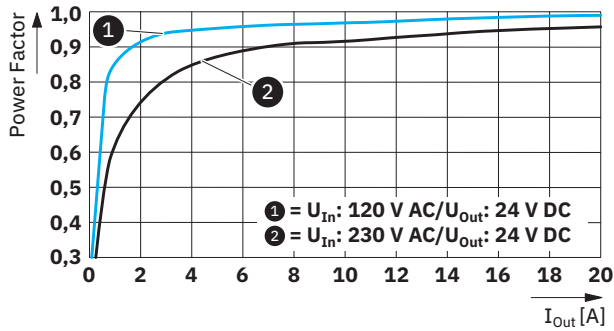

Crest factor	120 V AC	230 V AC
	typ. 1.77	typ. 1.6

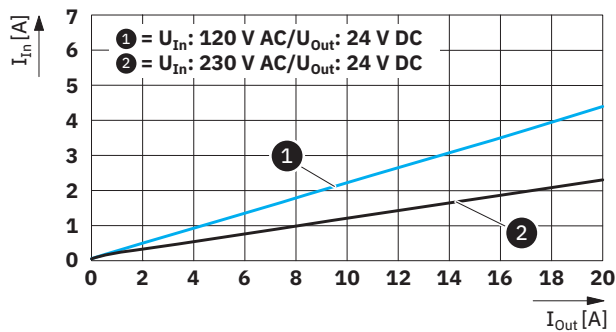
Input current vs. output current

Connection data: Input

Position	1.x	
Position identifier	1.1 (L+), 1.2 (N-), 1.3 (\ominus)	
Connection method	Push-in connection	
Stripping length	10 mm (rigid/flexible) / 8 mm (Ferrule)	
Conductor cross section	Terminal block	recommended
1-conductor rigid	0.2 mm ² ... 4 mm ²	1.5 mm ²
1-conductor flexible	0.2 mm ² ... 2.5 mm ²	1.5 mm ²
1-conductor flexible with ferrule without plastic sleeve	0.25 mm ² ... 2.5 mm ²	1.5 mm ²
1-conductor flexible with ferrule with plastic sleeve	0.25 mm ² ... 1.5 mm ²	1.5 mm ²
1-conductor rigid (AWG) (Cu)	24 ... 12	16

Output data

Nominal output voltage (U_N)	24 V DC
Setting range of the output voltage (U_{Set}) > 24 V DC, constant capacity restricted	24 V DC ... 28 V DC
Output current I_N / $I_{Dyn.Boost}$	20 A / max. 30 A (5 s)
Output power P_N / $P_{Dyn.Boost}$	480 W / max. 720 W (5 s)
Control deviation	
change in input voltage ± 10 %	< 0.1 %
change in load, dynamic 10 % ... 90 %	< 3 %
change in load, static 10 % ... 90 %	< 1 %
Short-circuit-proof	yes
No-load proof	yes
Residual ripple	typ. 50 mV _{PP}
Connection in parallel	yes, for increased efficiency and redundancy
Connection in series	yes, for increased output voltage (observe SELV limit)
Feedback voltage resistance	≤ 35 V DC
Protection against overvoltage at the output (OVP)	≤ 35 V DC
Rise time $U_{Out} = 10$ % ... 90 %	≤ 1 s

Connection data: Output

Position	2.x	
Position identifier	2.1, 2.2 (+), 2.3, 2.4, 2.5 (-)	
Connection method	Push-in connection	
Stripping length	12 mm (rigid/flexible) / 12 mm (Ferrule)	
Conductor cross section	Terminal block	recommended
1-conductor rigid	0.2 mm ² ... 10 mm ²	4 mm ²
1-conductor flexible	0.2 mm ² ... 6 mm ²	4 mm ²
1-conductor flexible with ferrule without plastic sleeve	0.25 mm ² ... 6 mm ²	4 mm ²
1-conductor flexible with ferrule with plastic sleeve	0.25 mm ² ... 6 mm ²	4 mm ²
1-conductor rigid (AWG) (Cu)	24 ... 8	12

LED DC OK – signal state operation (U_N = 24 V DC, I_{Out} = I_N)

Function	Visual operating state display
Color	red, yellow, green (multicolor LED)
LED Off	Supply voltage input AC not present
LED On (green), DC OK	U _{Out} > 21 V DC and I _{Out} < 0.9 x I _N
LED On (yellow), I _{Out} > 90%	U _{Out} > 21 V DC and I _{Out} > 0.9 x I _N
LED On (red), I _{SHORT}	U _{Out} < 21 V DC and I _{Out} > 0.9 x I _N
LED On (flashing red)	U _{OUT} > OVP (Over voltage protection)

Switching contact DC OK – signal state operation (U_N = 24 V DC, I_{Out} = I_N)

Position	3.x
Position identifier	3.1 (13), 3.2 (14)
Function	Operating state forwarding
Switch contact (floating)	OptoMOS
Switching voltage	max. 30 V DC (SELV)
Current carrying capacity	max. 100 mA
State condition	
Contact closed	U _{Out} > 21 V DC and I _{Out} < 0.9 x I _N
Contact open	U _{Out} < 21 V DC or I _{Out} > 0.9 x I _N (averaging over 60 s)



Exclusion of false positives

If the mean value of the output current I_{Out} > 0.9 x I_N over the last 60 seconds is recognized as a precondition for switching, the contact opens. Mean-value generation protects you preventively against false positives in case of temporary voltage or current changes caused by the DC load.

Connection data: Signal

Position	3.x	
Position identifier	3.1 (13), 3.2 (14)	
Connection method	Push-in connection	
Stripping length	10 mm (rigid/flexible) / 8 mm (Ferrule)	
Conductor cross section	Terminal block	recommended
1-conductor rigid	0.2 mm ² ... 1.5 mm ²	0.5 mm ²
1-conductor flexible	0.2 mm ² ... 1.5 mm ²	0.5 mm ²
1-conductor flexible with ferrule without plastic sleeve	0.25 mm ² ... 1.5 mm ²	0.5 mm ²
1-conductor flexible with ferrule with plastic sleeve	0.25 mm ² ... 0.75 mm ²	0.5 mm ²
1-conductor rigid (AWG) (Cu)	24 ... 16	20

Reliability

	25 °C	40 °C	60 °C
MTBF (IEC 61709, SN 29500)			
230 V AC	> 1400000 h	> 770000 h	> 310000 h

General data

Degree of protection	IP20
Protection class	I
With protective coating	yes
Flammability rating UL 94	
Housing, terminal blocks	V0
Dimensions (W x H x D)	55 x 135 x 132 mm
Device depth (DIN rail mounting)	125 mm
Weight	940 g

Power dissipation

	120 V AC	230 V AC
No load	< 1.3 W	< 1.37 W
Nominal load	< 33.37 W	< 26.72 W

Efficiency

	120 V AC	230 V AC
	typ. 93.8 %	typ. 95 %

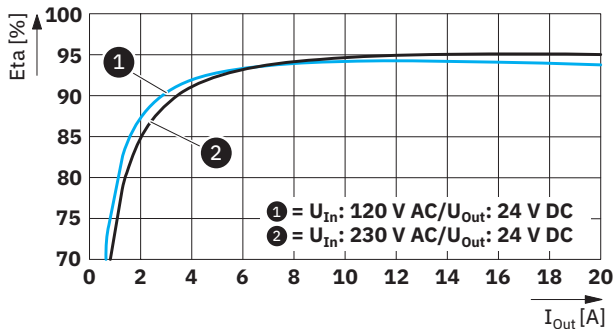

Ambient conditions

Ambient temperature (operation) -25 °C ... 70 °C (> 60 °C Derating: 2,5 %/K)



The ambient temperature (operation) refers to IEC 61010 surrounding air temperature.

Ambient temperature (start-up type tested) -40 °C

Ambient temperature (storage/transport) -40 °C ... 85 °C

Max. permissible relative humidity (operation) ≤ 95 % (at 25 °C, non-condensing)

Installation height ≤ 5000 m (> 2000 m, Derating: 10 %/1000 m)

Vibration (operation)

IEC 60068-2-6 10 Hz ... 50 Hz, amplitude ±0.2 mm
50 Hz to 150 Hz, 2.3 g, 90 min.

Shock (operation)

IEC 60068-2-27 18 ms, 30g, per spatial direction

Degree of pollution 2

Climate class

EN 60721 3K3

Overvoltage category

EN 61010-1 III (≤ 2000 m) / II (≤ 5000 m)

EN 61010-2-201 III (≤ 2000 m) / II (≤ 5000 m)

Standards/specifications

Safety of power supply units up to 1100 V (insulation distances) DIN EN 61558-2-16

Electrical safety IEC 61010-2-201 (SELV)

Equipping high voltage installations with electronic equipment EN 50178/VDE 0160 (PELV)

Safety for equipment for measurement, control, and laboratory use IEC 61010-1

Protective extra-low voltage IEC 61010-1 (SELV) IEC 61010-2-201 (PELV)

Safe isolation IEC 61558-2-16 IEC 61010-2-201

Limitation of harmonic line currents EN 61000-3-2

Mains variation/undervoltage SEMI F47 EN 61000-4-11

Conformance/Approvals

UL

UL/C-UL Listed UL 61010-1

UL/C-UL Listed UL 61010-2-201

ANSI/UL 121201

PROCESS CONTROL EQUIPEMENT FOR HAZARDOUS LOCATIONS

(EN) • This equipment is suitable for use in Class I, Division 2, Groups A, B, C and D, Hazardous Locations, or non-hazardous locations only.

(FR) • Cet appareil convient uniquement pour une utilisation en atmosphères explosibles de classe I, division 2, groupes A, B, C et D ou en atmosphères non explosibles.

(EN) • WARNING: Explosion Hazard - Do not connect or disconnect equipment unless power has been switched off or the area is known to be non-hazardous.

(FR) • AVERTISSEMENT : risque d'explosion - ne pas connecter ou déconnecter les équipements sauf si l'alimentation a été coupée ou si la zone est réputée non dangereuse.

(EN) • If the equipment is used in a manner not specified by the manufacturer, the protection provided by the equipment may be impaired.

(FR) • Si l'équipement est utilisé d'une manière non spécifiée par le fabricant, la protection fournie par cet équipement peut être altérée.

(EN) • This equipment must be installed in a suitable, tool secured/key locked enclosure.

(FR) • Cet équipement doit être installé dans un boîtier approprié, verrouillé par une clé ou dont l'ouverture nécessite l'utilisation d'un outil.



You will find the latest approvals for the item at phoenixcontact.com/products.

Electromagnetic compatibility		
Conformance with EMC Directive 2014/30/EU		
Interference emission in accordance with EN 61000-6-3 (residential and commercial) and EN 61000-6-4 (industrial)		
CE basic standard	Minimum normative requirements	Higher requirements in practice (covered)
Conducted noise emission EN 55016	EN 61000-6-4 (Class A)	EN 61000-6-3 (Class B)
Noise emission EN 55016	EN 61000-6-4 (Class A)	EN 61000-6-3 (Class B)
Harmonic currents EN 61000-3-2	EN 61000-3-2 (Class A)	EN 61000-3-2 (Class A)
Flicker EN 61000-3-3	not required	EN 61000-3-3
Noise emission for marine approval		
	Minimum normative requirements of DNV	Higher requirements in practice of DNV (covered)
DNV conducted interference emission	Class A Area power distribution	Class A Area power distribution
DNV interference radiation	Class A Area power distribution	Class B Bridge and deck area
Immunity in accordance with EN 61000-6-1 (residential), EN 61000-6-2 (industrial)		
CE basic standard	Minimum normative requirements of EN 61000-6-2 (CE)	Higher requirements in practice (covered)
Electrostatic discharge EN 61000-4-2		
Housing contact discharge	4 kV (Test Level 2)	6 kV (Test Level 3)
Housing air discharge	8 kV (Test Level 3)	8 kV (Test Level 3)
Comments	Criterion B	Criterion B
Electromagnetic HF field EN 61000-4-3		
Frequency range	80 MHz ... 1 GHz	80 MHz ... 1 GHz
Test field strength	10 V/m (Test Level 3)	10 V/m (Test Level 3)
Frequency range	1.4 GHz ... 6 GHz	1 GHz ... 6 GHz
Test field strength	3 V/m (Test Level 2)	10 V/m (Test Level 3)
Comments	Criterion A	Criterion A
Fast transients (burst) EN 61000-4-4		
Input	asymmetrical 2 kV (Test Level 3)	asymmetrical 2 kV (Test Level 3)
Output	asymmetrical 1 kV (Test Level 2)	asymmetrical 2 kV (Test Level 3)
Signal	asymmetrical 1 kV (Test Level 3)	asymmetrical 1 kV (Test Level 3)
Comments	Criterion B	Criterion A

Immunity in accordance with EN 61000-6-1 (residential), EN 61000-6-2 (industrial)			
CE basic standard		Minimum normative requirements of EN 61000-6-2 (CE)	Higher requirements in practice (covered)
Surge voltage load (surge) EN 61000-4-5			
	Input	symmetrical 1 kV (Test Level 3) asymmetrical 2 kV (Test Level 3)	symmetrical 2 kV (Test Level 4) asymmetrical 4 kV (Test Level 4)
	Output	symmetrical 0.5 kV (Test Level 2) asymmetrical 1 kV (Test Level 2)	symmetrical 1 kV (Test Level 3) asymmetrical 2 kV (Test Level 3)
	Signal	asymmetrical 1 kV (Test Level 2)	asymmetrical 1 kV (Test Level 2)
	Comments	Criterion B	Criterion A
Conducted interference EN 61000-4-6			
	Input/Output/Signal	asymmetrical	asymmetrical
	Frequency range	0.15 MHz ... 80 MHz	0.15 MHz ... 80 MHz
	Voltage	10 V (Test Level 3)	10 V (Test Level 3)
	Comments	Criterion A	Criterion A
Voltage dips EN 61000-4-11			
Input voltage (230 V AC, 50 Hz)			
	Voltage dip	70 %, 25 periods (Class 3)	70 % , 25 periods (Class 3)
	Comments	Criterion C	Criterion A
	Voltage dip	40 %, 10 periods (Class 3)	40 %, 10 periods (Class 3)
	Comments	Criterion C	Criterion B
	Voltage dip	0 %, 1 period (Class 3)	0 %, 1 period (Class 3)
	Comments	Criterion B	Criterion A

Key

- Criterion A Normal operating behavior within the specified limits.
- Criterion B Temporary impairment to operational behavior that is corrected by the device itself.
- Criterion C Temporary adverse effects on the operating behavior, which the device corrects automatically or which can be restored by actuating the operating elements.

5 Safety and installation notes

5.1 Symbols used

Instructions and possible hazards are indicated by corresponding symbols in this document.



This is the safety alert symbol. It is used to alert you to potential personal injury hazards. Obey all safety measures that follow this symbol to avoid possible personal injuries.

There are different categories of personal injury that are indicated by a signal word.



WARNING

This indicates a hazardous situation which, if not avoided, could result in death or serious injury.



CAUTION

This indicates a hazardous situation which, if not avoided, could result in minor or moderate injury.



CAUTION: Hot surface

Please note that the surfaces of the power supply can become hot due to internal and external heating.

The following symbols are used to indicate potential damage, malfunctions, or more detailed sources of information.



NOTE

This symbol together with the signal word NOTE and the accompanying text alert the reader to a situation which may cause damage or malfunction to the device, hardware/software, or surrounding property.



This symbol and the accompanying text provide the reader with additional information or refer to detailed sources of information.



This symbol and the accompanying text provide additional information on the proper disposal of electronic components.



This symbol and the accompanying text provide additional information on recycling.



This symbol indicates a specialist product that requires specialist knowledge during installation.



This symbol identifies a specialist product in which a switched-mode power supply (SMPS) transformer is installed.



This symbol identifies a specialist product in which the installed safety transformer (SMPS) is short-circuit-proof.



This symbol refers to a PCB with protective coating for protection against critical ambient conditions (aerosols, dusts, etc.)

5.2 Safety and warning notes



WARNING: Danger to life by electric shock!

- Only skilled persons may install, start up, and operate the device.
- Never carry out work when voltage is present.
- Establish connection correctly and ensure protection against electric shock.
- Cover termination area after installation in order to avoid accidental contact with live parts (e. g., installation in control cabinet).



NOTE

- The power supply is maintenance-free. Repairs may only be carried out by the manufacturer. The warranty no longer applies if the housing is opened.
- Observe the national safety and accident prevention regulations.
- Assembly and electrical installation must correspond to the state of the art.
- The power supply is a built-in device and is designed for mounting in a control cabinet.
- A suitable electrical and fire enclosure shall be provided in the end equipment.
- The IP20 degree of protection of the power supply is intended for a clean and dry environment.
- Observe mechanical and thermal limits.
- Mount the power supply in the normal mounting position. The L(+)/N(-)/⊕ connection terminal blocks are located at the bottom.

- The power supply is approved for connection to TN, TT, and IT power grids (star networks) with protective conductor connection (PE) and a maximum phase-to-phase voltage of 240 V AC.
- Connect the housing to ground via protective conductor device terminal block ⊕.
- Make sure that the wiring on the primary side and the secondary side is adequately dimensioned and protected.
- Use copper cables for operating temperatures of >75 °C (ambient temperature <55 °C) >90 °C (ambient temperature <75 °C).
- Refer to the corresponding tables (see Section: Technical data) for the connection parameters, such as the necessary stripping length for wiring with and without ferrule.
- Protect the device against foreign bodies penetrating it, e.g., paper clips or metal parts.
- When wiring the floating switch contact, observe the maximum permissible contact load.



NOTE: Damage to the Push-in connection terminal blocks is possible

If you need to perform measurements with a multimeter, for example, do not insert the test probe directly into the Push-in connection terminal block.

The maximum pluggable depth of the wiring space of the Push-in connection terminal blocks is limited. In addition, when the test probe is inserted, the opening for release may be covered, meaning that it is not possible to insert a screwdriver sufficiently in order to activate the release mechanism.

The Push-in connection terminal block will be damaged if the release mechanism is not pressed correctly when removing the connecting cable. Use a suitable screwdriver to release the Push-in connection terminal block.

Figure 1 Incorrect use of a test probe

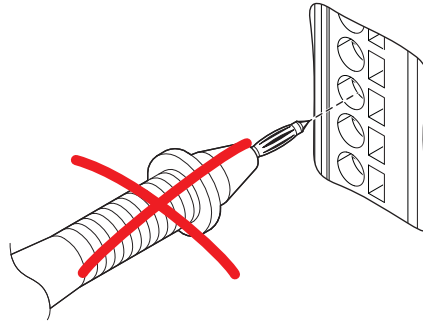

Only use test probes in combination with a conductive test adapter.

Figure 2 Correct use of a test probe

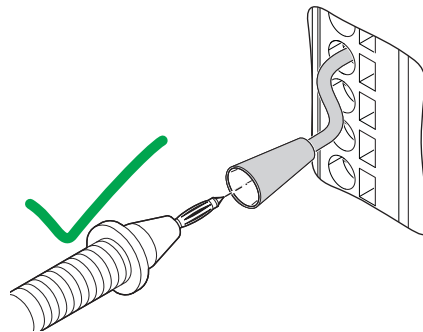

5.3 Intended use

- Use this power supply to convert the electrical energy fed in by the power grid. The AC input voltage is electrically isolated from the DC output voltage. The adjustable DC output voltage U_{Out} is a safety extra-low voltage.
- Protection may be impaired if the equipment is used in a manner not specified by the manufacturer.

6 High-voltage test (HIPOT)

This protection class I power supply is subject to the Low Voltage Directive and is factory tested. During the HIPOT test (high-voltage test), the insulation between the input circuit and output circuit is tested for the prescribed electric strength values, for example. The test voltage in the high-voltage range is applied at the input and output terminal blocks of the power supply. The operating voltage used in normal operation is a lot lower than the test voltage used.



High-voltage tests can be performed as described.

The test voltage should rise and fall in ramp form. The relevant rise and fall time of the ramp should be at least two seconds.

6.1 High-voltage dielectric test (dielectric strength test)

In order to protect the user, power supplies (as electric components with a direct connection to potentially hazardous voltages) are subject to more stringent safety requirements. For this reason, permanent safe electrical isolation between the hazardous input voltage and the touch-proof output voltage as safety extra-low voltage (SELV) must always be ensured.

In order to ensure permanent safe isolation of the AC input circuit and DC output circuit, high-voltage testing is performed as part of the safety approval process (type test) and manufacturing (routine test).

6.2 High-voltage dielectric test during the manufacturing process

During the power supply manufacturing process, a high-voltage test is performed as part of the dielectric test in accordance with the specifications of IEC/UL/EN 61010-1. Routine manufacturing tests are inspected regularly by a certification authority.

6.3 High-voltage dielectric test performed by the customer

Apart from routine and type tests to guarantee electrical safety, the end user does not have to perform another high-voltage test on the power supply as an individual component. According to EN 60204-1 (Safety of machinery - Electrical equipment of machines) the power supply can be disconnected during the high-voltage test and only installed once the high-voltage test has been completed.

6.3.1 Performing high-voltage testing

If high-voltage testing of the control cabinet or the power supply as a stand-alone component is planned during final inspection and testing, the following features must be observed.

- The power supply wiring must be implemented as shown in the wiring diagram.
- The maximum permissible test voltages must not be exceeded.

Avoid unnecessary loading or damage to the power supply due to excessive test voltages.



For the relevant applicable test voltages and insulation distances, refer to the corresponding table (see technical data: electric strength of the insulation section).

Figure 3 Potential-related wiring for the high-voltage test

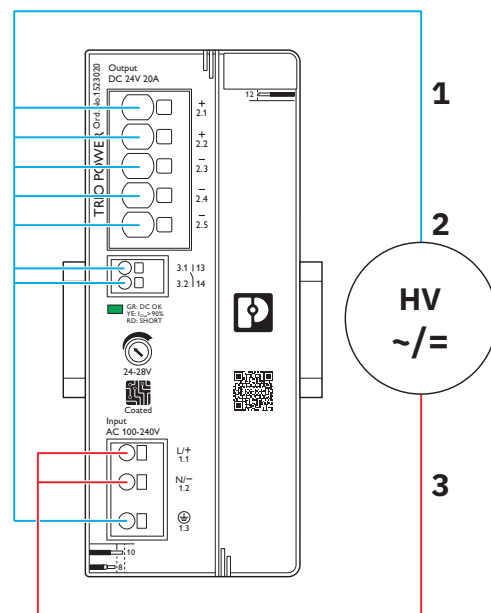

Key

No.	Designation	Color coding	Potential levels
1	DC output circuit	Blue	Potential 2
2	High-voltage tester	--	--
3	AC input circuit	Red	Potential 1

7 Structure

7.1 Rating plate

In accordance with the German Product Safety Law (ProdSG) it is only permissible to make such products available on the market if they meet certain safety standards. It must be ensured at all times that users are not exposed to hazards.

In accordance with ProdSG, every device must therefore be fitted with a rating plate. All relevant information on the safe use of the device must also be included.



The power supply device rating plate is located on the right-hand side of the housing (as viewed from the front).

Figure 4 Rating plate information

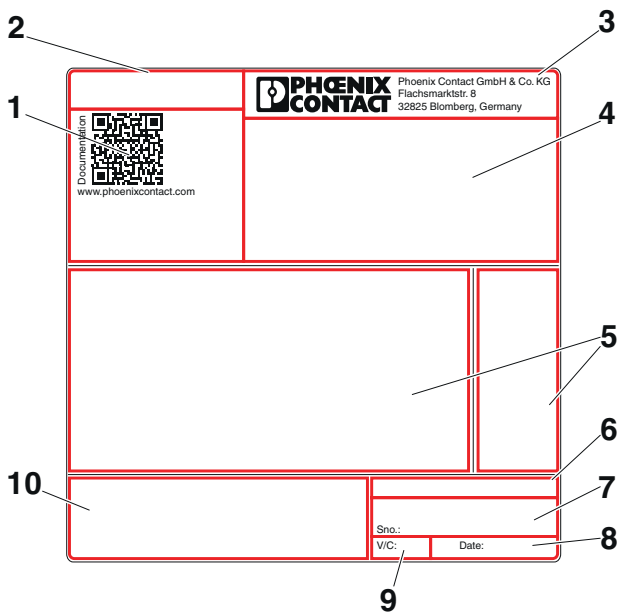

Key:

No.	Designation
1	QR code as web link to the device documentation
2	Order designation and item number
3	Identification of the provider
4	Device connection data and permissible ambient conditions
5	Device approvals
6	Marking for the production facility within the PHOENIX Contact Group
7	Bar code and serial number for device identification
8	Date of manufacture
9	Marking for the V/C level
10	Reference to the accompanying product documentation

7.2 Connection terminal blocks and function elements

For clear and definitive identification, the connection terminal block is marked with an unambiguous connection marking. The connection marking always comprises two items of information: the position marking (position) and the pole marking (pole identifier).

Example:

Position	Pole identifier	Connection labeling
1.x	x.1 (L/+), x.2 (N/-), x.3 (⊕)	Input
2.x	x.1, x.2 (+), x.3, x.4, x.5 (-)	Output
3.x	x.1 (13), x.2 (14)	Signal

Figure 5 Position of the connection terminal blocks and function elements

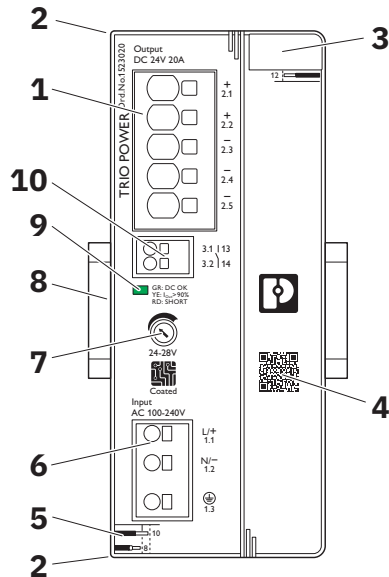

Key:

No.	Designation	Connection labeling
1	Output voltage connection terminal blocks: Output DC (2x positive/ 3x negative)	2.1 ... 2.5
2	Accommodation for cable binders	--
3	Marker carriers for plant and location identification	--
4	QR code web link	--
5	Help for stripping lengths (with/without ferrule)	--
6	Input voltage connection terminal blocks: Input AC L(+)/N(-)/⊕	1.1 ... 1.3
7	Potentiometer output voltage	--
8	Universal DIN rail adapter (rear of housing)	--
9	LED status indicator (multicolor LED, red, yellow, green)	--
10	Connection terminal blocks, floating switch contact: 13/14 (N/O contact)	3.1 ... 3.2

7.3 Block diagram

Figure 6 Block diagram

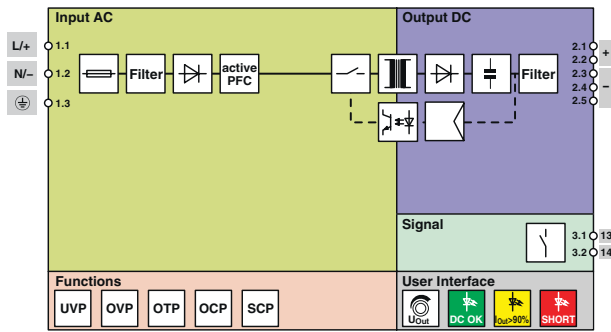

Key:

Symbol	Designation – Input AC, Output DC
	Input fuse, internal device protection
	EMC filter
	Rectification
	Power factor correction (PFC)
	Switching transistor
	Transmitter with electrical isolation
	Smoothing capacitor
	Optocoupler (electrically isolating)
	Control equipment

Symbol	Designation – Functions
	Undervoltage protection protects the AC input of the power supply against damage in the event of an AC undervoltage.
	Overvoltage protection protects the DC output of the power supply and the connected load against damage in the event of an overvoltage
	Overtemperature protection protects the power supply against damage in the event of impermissibly high intrinsic external heating.
	Overcurrent protection protects the DC output of the power supply against damage in the event of an impermissibly high current load.
	Short-circuit protection protects the DC output of the power supply against damage in the vent of an output-side short circuit.

Symbol	Designation – Signal
	Floating switch contact, signals the operating status of the power supply to a higher-level controller. The floating switch contact is closed in normal operation. $U_{Out} > 21 \text{ V DC}$ and $I_{Out} < 0.9 \times I_N$

Symbol	Designation – User interface
	Potentiometer for setting the output voltage U_{Out}
	The DC OK LED (green) visualizes the operating status of the power supply. In normal operation, the DC output voltage is at $U_{Out} > 21 \text{ V DC}$ and $I_{Out} < 0.9 \times I_N$.
	The DC OK LED (yellow) visualizes the operating status of the power supply as a pre-alarm. The output current supplying the loads is above the device-side threshold value of $I_{Out} > 0.9 \times I_N$ and $U_{Out} > 21 \text{ V DC}$.
	DC OK LED (red), visualizes the operating status of a detected short circuit on the DC output side of the power supply. DC OK LED (flashing red, 5 s), visualizes an impermissibly high voltage (OVP) that has been detected at the DC output terminals.

7.4 Dimensions

Figure 7 Dimensions, front view (in mm)

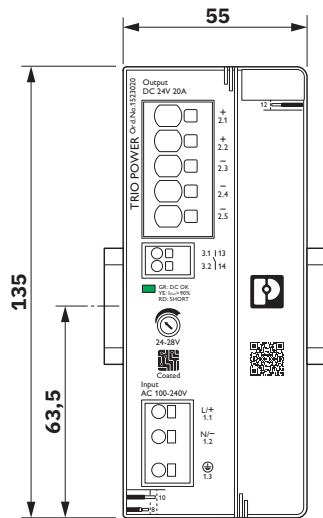
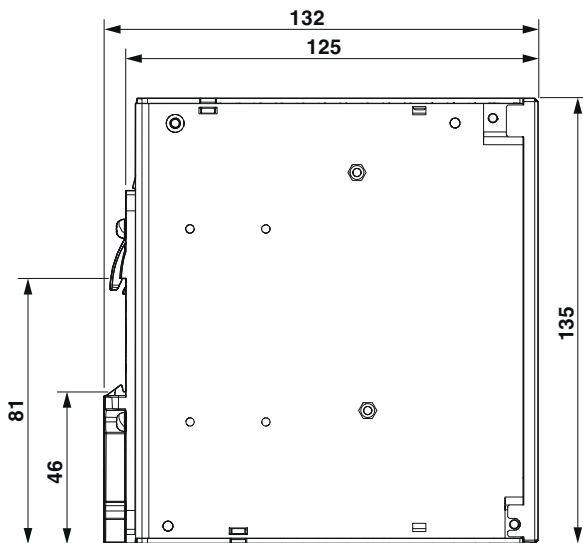

Figure 8 Dimensions, side view (in mm)



8 Mounting/remove

The fanless convection-cooled power supply can be snapped onto 35 mm DIN rails with a top hat profile (TH 35-7.5 / TH 35-15) in accordance with EN 60715.

8.1 Convection

To ensure sufficient convection, a minimum clearance is necessary between the power supply and above/below the installed devices. The minimum clearances are rated based on the standard mounting position with nominal power supply operation (see section: Restricted areas).

Figure 9 Schematic diagram of the convection cooling

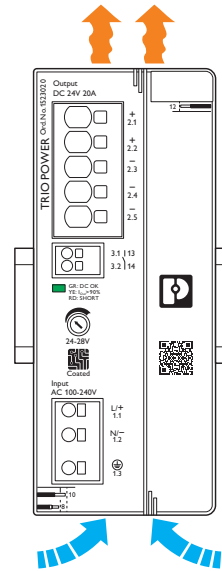

8.2 Mounting position

The specified technical data for the power supply is based on nominal operation in the standard mounting position. Any different technical data based on deviating mounting positions or other ambient conditions is labeled accordingly (see section: Derating).

Figure 10 Power supply installed in the normal mounting position

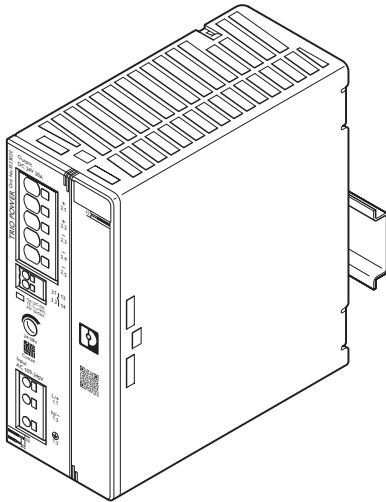

8.3 Installation height

You can operate the power supply without power limitations up to an installation altitude of 2000 m. For altitudes higher than 2000 m, different specifications apply due to the differing air pressure and the reduced convection cooling associated with this (see section: Derating).

8.4 Keep-out areas

To protect the power supply against thermal overload, observe the required keepout areas during configuration. The specified dimensions of the keepout areas are based on the normal mounting position of the power supply.

8.4.1 Variable keepout areas

The required dimensions of the keepout areas may vary depending on the planned output power for the application.

Output power $P_{Out} = 100\%$		Keepout areas, clearance [mm]		
		a	b	c
Passive components	$\leq 40\text{ }^\circ\text{C}$	0	50	50
	$> 40\text{ }^\circ\text{C}$	10	50	50
Active components		15	50	50

Figure 11 Device dimensions and minimum keep-out areas (in mm)

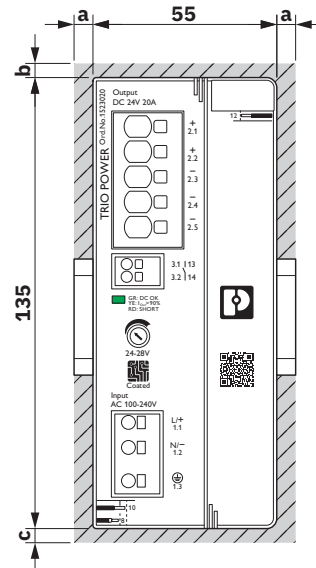

8.5 Mounting the power supply unit

8.5.1 Mounting on the DIN rail (snap-on foot)

To mount the power supply on a DIN rail, proceed as follows:

1. In the standard mounting position, the power supply is mounted on the DIN rail from the front. When doing so, ensure that the snap-on foot rests completely on the DIN rail (A).
2. Then push the power supply onto the DIN rail until the snap-on foot audibly snaps into place (B).
3. Check that the power supply is securely attached to the DIN rail.

Figure 12 Snapping the power supply onto the DIN rail

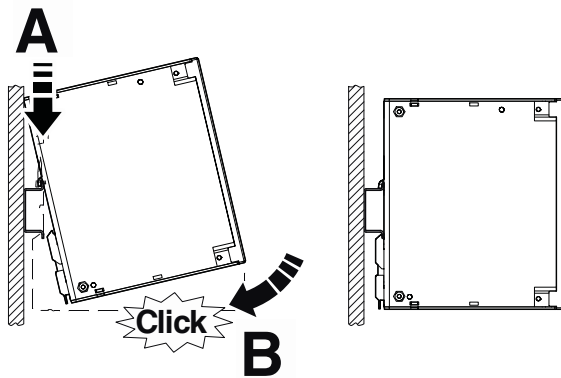

8.6 Removing the power supply unit

8.6.1 Removal from the DIN rail (snap-on foot)

To remove the power supply from the DIN rail, proceed as follows:

1. Take a suitable screwdriver and insert it into the interlock opening on the snap-on foot.
2. Release the latch by levering the screwdriver downwards (A).
3. Carefully swivel the power supply downwards (B) and let the interlock slide back into the starting position.
4. Then lift the power supply from the DIN rail.

Figure 13 Removing the power supply from the DIN rail

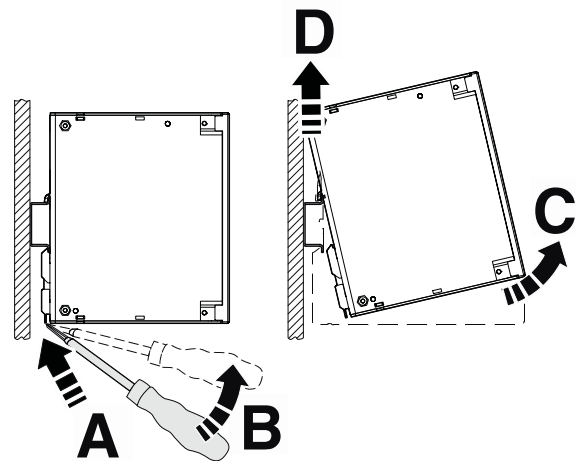

8.7 Retrofitting the universal DIN rail adapter (rotated by 90°, flat mounting position)

For example, for field use of the power supply in flat on-site distributors or in flat console installations, you have the option of retrofitting the universal DIN rail adapter that comes pre-mounted.

The universal DIN rail adapter is moved from the rear of the housing to the left side of the housing (as viewed from the front). The new mounting position of the power supply is rotated by 90° and the required installation depth is reduced.

The mounting of the power supply on the DIN rail is identical to the default delivery state. No additional mounting material is required to retrofit the universal DIN rail adapter.



Use the Torx® screws provided to attach the universal DIN rail adapter to the side. When doing so, please note that the hole pattern may differ from the default delivery state.

8.7.1 Disassembling the universal DIN rail adapter

Proceed as follows to remove the universal DIN rail adapter:

1. Remove the Torx® screws for the universal DIN rail adapter using a suitable screwdriver (size T10).
2. Remove the universal DIN rail adapter from the rear of the housing.

Figure 14 Disassembling the universal DIN rail adapter

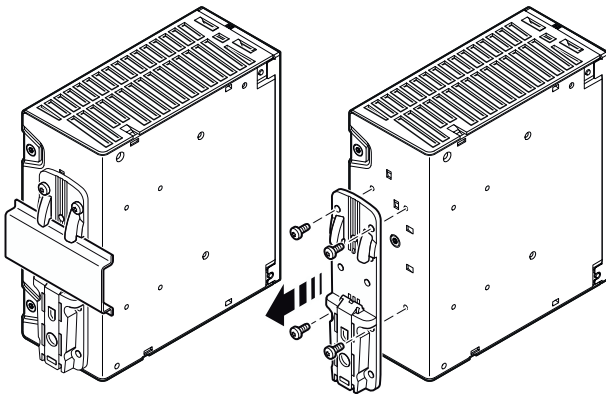

8.7.2 Mounting the universal DIN rail adapter

To mount the universal DIN rail adapter on the left side of the housing, proceed as follows:

1. Position the universal DIN rail adapter on the left side of the housing, so that the hole pattern lines up with the fixing holes on the side of the device.
2. Insert the Torx® screws through the fixing holes of the universal DIN rail adapter.
3. Screw the universal DIN rail adapter onto the left side of the power supply housing.



Observe the maximum tightening torque of the self-tapping Torx® screw (0.7 Nm).

Figure 15 Mounting the universal DIN rail adapter

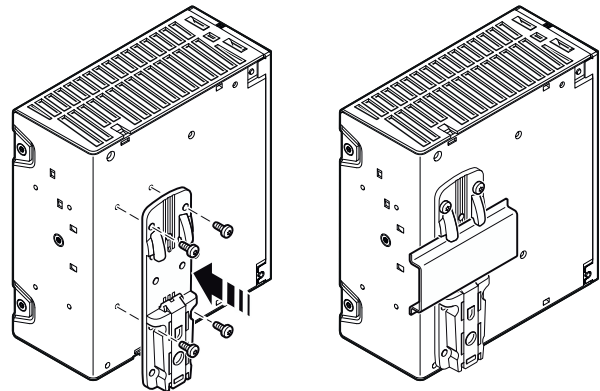

8.8 Retrofitting the UWA 182/52 mounting adapter

The UWA 182/52 mounting adapter (2938235) is a universal wall adapter for securely mounting the power supply in the event of extreme ambient conditions, e.g., strong vibrations. The mounting adapter is attached to a flat mounting surface with up to six mounting screws. The fixed screw connections between the power supply and mounting adapter result in very high mechanical stability.

i The UWA 182/52 mounting adapter enables mounting in combination with all Phoenix Contact power supplies. However, for mounting on the rear of the device, the power supply must come equipped with a removable universal DIN rail adapter. In addition, when using less powerful power supplies, observe the required mounting width of the UWA 182/52 mounting adapter which is 52 mm.

Alternatively, it is also possible to mount the UWA 182/52 mounting adapter on the left side of the power supply housing (as viewed from the front).

8.8.1 Disassembling the universal DIN rail adapter

Proceed as follows to remove the universal DIN rail adapter:

1. Remove the Torx® screws for the universal DIN rail adapter using a suitable screwdriver (size T10).
2. Remove the universal DIN rail adapter from the rear of the device.

Figure 16 Replacing UTA 107/30 with UWA 182/52

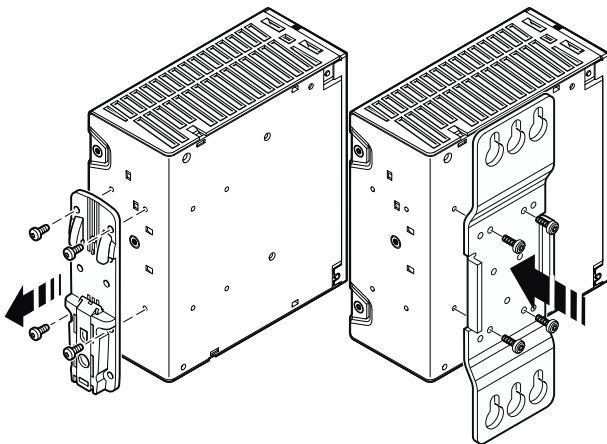

8.8.2 Mounting the UWA 182/52 mounting adapter

i Use the Torx® screws provided to attach the universal DIN rail adapter to the side of the housing. When doing so, please note that the hole pattern may differ from the default delivery state.

To mount the UWA 182/52 mounting adapter on the rear of the device or the left side of the device, proceed as follows:

1. Position the UWA 182/52 mounting adapter on the rear of the device or the left side of the housing, so that the hole pattern lines up with the fixing holes on the side of the housing.

i At the same time, ensure the UWA 182/52 assembly adapter is aligned correctly. When the larger openings of the lower keyholes are at the bottom, you can securely attach the UWA 182/52 mounting adapter to the mounting screws.

2. Insert the Torx® screws through the fixing holes of the UWA 182/52 assembly adapter.
3. Screw the UWA 182/52 mounting adapter onto the back of the device or the side of the power supply housing.

i Observe the maximum tightening torque of the self-tapping Torx® screw (0.7 Nm).

Figure 17 UWA 182/52 mounted on left housing side

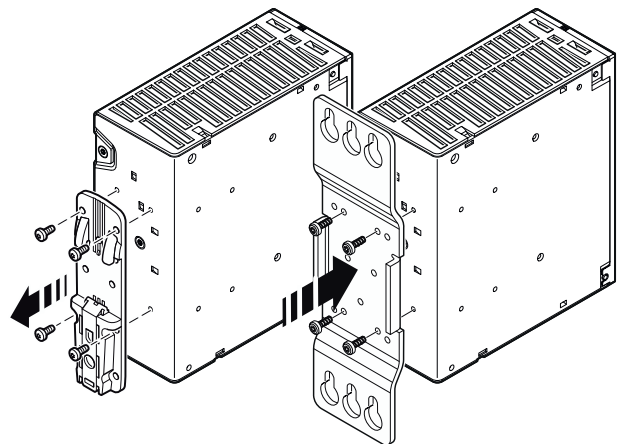

8.8.3 Fixing the UWA 182/52 mounting adapter with power supply to a mounting surface

For screw fixing on a flat mounting surface, use the appropriate number of screws for the relevant mounting surface (e.g., M6 x 40, ISO 4762 or hexalobular internal driving screws, e.g., M6 x 40, ISO 10664).

To mount the UWA 182/52 mounting adapter with a power supply, proceed as follows:

1. Copy the drilling pattern onto the substructure or mounting surface.
2. Select suitable fixing material depending on the substructure or mounting surface.
3. Drill the necessary number of drill holes using a suitable drill, depending on the type of fixing (threaded or wall plug mounting).
4. Prepare the drill holes (tap M6 thread or insert 8 x 70 mm dowel).
5. Fix the UWA 182/52 mounting adapter in place using the appropriate number of screws and spring washers.
6. Check that the UWA 182/52 assembly adapter is fixed securely.

Figure 18 Dimensions for the attachment of the UWA assembly adapter 182/52

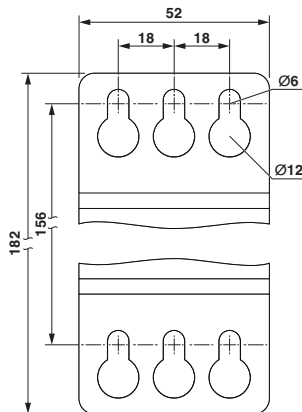
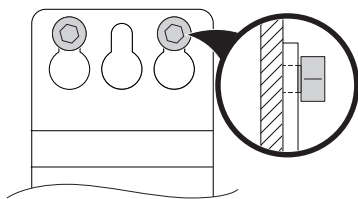

Figure 19 Schematic diagram, screw fixing to the mounting surface



9 Connection terminal blocks



This power supply is a specialist product. Only qualified specialist personnel with electrotechnical expertise may install, start up, and operate this power supply.



WARNING: Observe the national safety regulations for working on electrical systems

In Germany, this work may only be carried out by electrically skilled persons with additional training.

Furthermore, the five basic safety rules apply:

- Disconnect safely
- Ensure power cannot be switched on again
- Verify safe isolation from the supply for all positions
- Ground and short circuit
- Cover or safeguard adjacent live parts

9.1 Push-in connection terminal blocks

The front connection terminal blocks of the power supply feature Push-in connection technology. For clear identification, the connection terminal blocks are marked with the respective connection marking. See section: Connection terminal blocks and function elements.



For the necessary connection parameters for the connection terminal blocks, refer to the technical data section.

In addition, you can also find the required stripping lengths for flexible and rigid connecting cables printed on the front of the power supply.

9.1.1 Wiring the Push-in connection terminal block

To wire the power supply with the connecting cables, proceed as follows:

1. Strip the individual connecting cables and, if necessary, fit the conductor ends with ferrules.
2. Insert the stripped end of the connecting cable into the center of the round contact opening of the connection terminal block as far as it will go. When you plug the connecting cable into the contact opening, the contact mechanism opens automatically.
3. Then check that the connecting cable is fixed securely in the contact opening.



If you use rigid connecting cables or flexible connecting cables with ferrules to wire the power supply, no additional tools are required.

If wiring a flexible connecting cable without ferrule, you need to open the contact mechanism with a screwdriver (see section: Opening the Push-in connection terminal block).



NOTE: Observe mechanical loads

Avoid any mechanical loads on the connecting cables, otherwise the electrical contact is at risk. (See section: Securing the connecting cables)

Make sure there is enough space for the wiring in the wiring space.

Figure 20 Schematic diagram of the insertion of the connecting cable

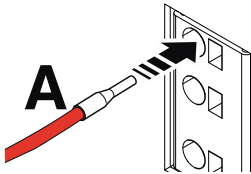

9.1.2 Opening the Push-in connection terminal block

To remove the connecting cable from the Push-in connection terminal blocks, proceed as follows:

1. Ensure that the power supply is disconnected from all power sources.
2. To open the connection terminal blocks, insert a suitable screwdriver into the square opening for release. Then carefully push the screwdriver to release the connection terminal block. The contact mechanism opens and the connecting cable is released.
3. Pull the connecting cable out of the connection terminal block. Secure the uninsulated end of the connecting cable using a suitable insulating clamp.
4. Then remove the screwdriver from the square opening for release. The contact mechanism closes again.

Figure 21 Refer to the schematic diagram of the connecting cable

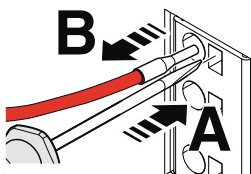

9.2 AC input terminal blocks

The power supply is designed to be operated on single-phase AC power grids or on two line conductors of three-phase systems. Here, the star network supports various supply system configurations, for example TT, TN, and IT systems. Supply by a DC power grid is also possible.

The power supply is connected on the primary side via the Input AC connection terminal blocks (position 1.x, input).

Figure 22 Position of the AC input terminal blocks

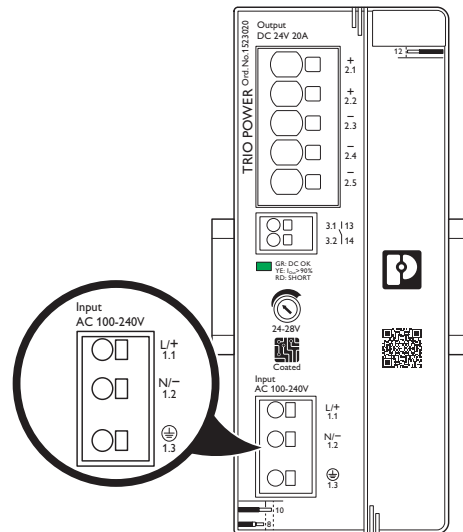

9.3 Primary-side fuse protection and connection

The installation of the power supply must conform to the regulations of EN 61010. It must be possible to switch the power supply off using a suitable disconnection device outside of the power supply. For example, the primary-side line protection is suitable for this (see section: Technical data, input protection).

9.3.1 1AC supply network



NOTE: Observe the maximum permissible input voltage

The power supply is approved for connection to TN, TT, and IT power grids (PE) with a maximum phase-to-phase voltage of 240 V AC.

Figure 23 Schematic diagram, single-phase fuse protection

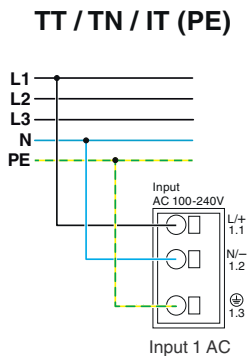

9.3.2 3AC supply network (2-phase mode)



DANGER: Hazardous voltage

When operating the power supply on a three-phase system, observe the maximum permissible phase-to-phase voltage (see section: Technical data, input data).

The primary-side fuse protection in two-phase operation must be cover all poles.

Figure 24 Schematic diagram, two-phase fuse protection

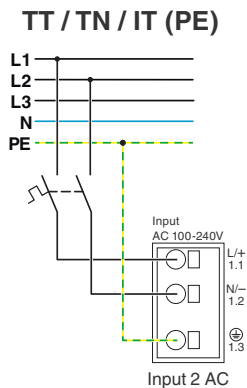

9.3.3 DC supply network



DANGER: Hazardous voltage

When operating the power supply on a DC voltage system, observe the maximum permissible input voltage (see section: Technical data, input data).

The primary-side fuse protection in DC operation must cover all poles.



NOTE: Damage possible if an incorrect fuse is used

In DC operation, only use fuses that are approved for DC voltages.

Figure 25 Schematic diagram, two-phase fuse protection

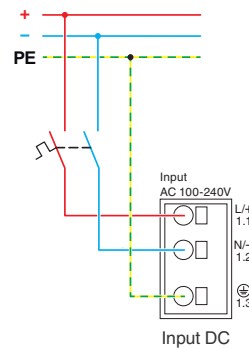

9.4 DC output terminal blocks

Connect the DC load to be supplied to the Output DC connection terminal blocks (position 2.x, output). By default, the power supply is preset to a nominal output voltage of 24 V DC. The level of the DC output voltage can be changed (see section: Function elements).

Figure 26 Position of DC output terminals

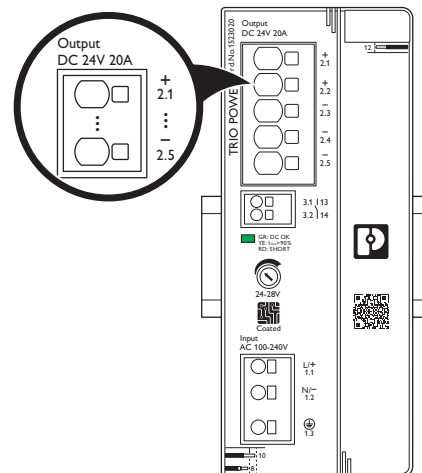

9.4.1 Wiring principle for DC output terminals

The power supply has connection terminal blocks with positive potential and negative potential for supplying DC loads. Connect the DC loads to be supplied to these connection terminal blocks.

Figure 27 Wiring principle for DC output terminal blocks

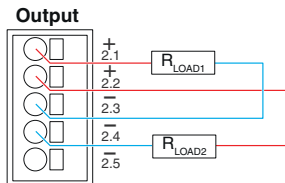

9.4.2 Additional negative terminal

As per the Machinery Directive DIN EN 60204-1 (VDE 0113-1), the protection of people against electric shock must always be ensured. For operational reasons, the negative potential of the protective extra-low voltage (PELV) is grounded on the secondary side.

Figure 28 Wiring principle for the additional negative terminal

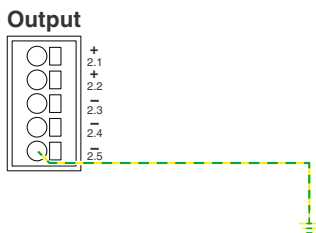

Example: No grounding on the secondary side



WARNING: Machine startup due to ground fault

A ground fault is an impermissible connection to PE. A ground fault occurs when a conductor with damaged insulation touches the grounded housing.

A double ground fault can mean that the short circuit via a button in the control circuit causes an unintentional machine start.

Figure 29 Schematic diagram of double ground fault

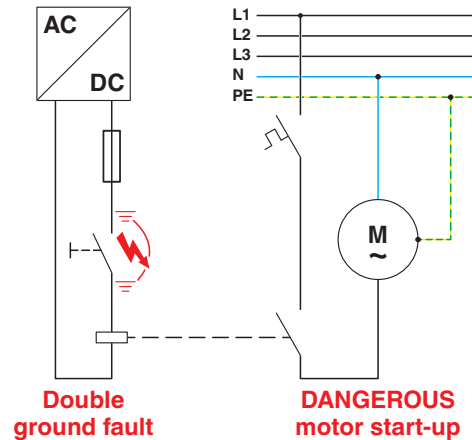

Example: Grounding on the secondary side

The secondary-side grounding of the negative potential (additional negative terminal) defines an intentional ground fault. Each additional and unintentional ground fault on the secondary side results in a short circuit of the DC output voltage. The upstream fuse trips. The faulty control circuit is switched off. An impermissible machine start, e.g., due to motor startup, is not possible.

Figure 30 Schematic diagram with secondary-side grounding

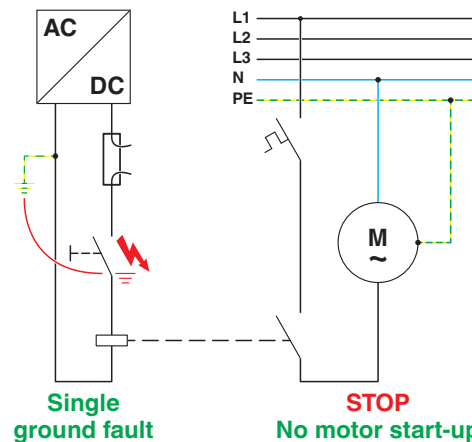

9.4.3 Protection of the secondary side

The power supply is electronically short-circuit-proof and no-load-proof. In the event of a fault, the output voltage and the output current are limited.



If sufficiently long connecting cables are used, fuse protection does not have to be provided for each individual load.

9.5 Floating switch contact

There is a floating switch contact at connection terminal blocks 13/14 (position 3.x, signal) for forwarding data to a higher-level control system.

Figure 31 Position of the floating switch contact

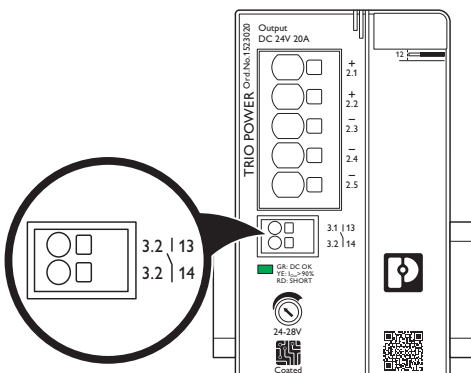

9.5.1 Wiring principle for the floating switch contact

In normal operation of the power supply, the floating switch contact (13/14) acts as a N/O contact (open circuit principle). To report operational readiness to a higher-level controller, the floating switch contact is connected to a 24 V DC voltage, for example.

The following operating states of the power supply open the floating switch contact:

- When the AC input voltage that is being supplied is below the minimum required AC voltage range.
- The DC output voltage drops below the threshold value of $U_{Out} < 21 \text{ V DC}$.
- The DC output current exceeds the threshold value of $I_{Out} > 0.9 \times I_N$ ($U_{Out} > 21 \text{ V DC}$) after mean-value generation of the last 60 s.



NOTE: Observe maximum contact load

When wiring the floating switch contact, observe the maximum permissible contact load (30 V DC, 100 mA).

An impermissibly high load on the switch contact can result in malfunctions or irreversible damage. Correct signaling to the higher-level controller is then no longer ensured.

Figure 32 Wiring principle for the floating switch contact

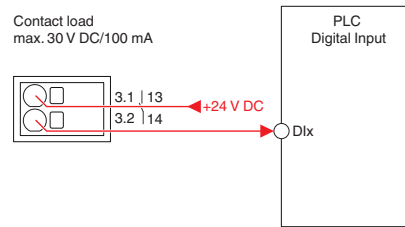

9.6 Securing the connecting cables

Receptacles for securing the bundled connecting cables are integrated at the top and bottom of the left side of the power supply housing (as viewed from the front). Use cable ties (3240744, WT-HF 3,6X140), which are available as an option, to secure the connecting cables.

To secure the connecting cables, proceed as follows:

1. Wire the power supply with sufficient connection reserve (input, output, and signal terminal blocks).
2. Bundle and arrange the connecting cables so that the cooling grilles on the top and bottom of the housing are covered as little as possible.
3. Thread the cable ties into the necessary receptacles for the cable ties.

Figure 33 Laying and aligning connecting cables

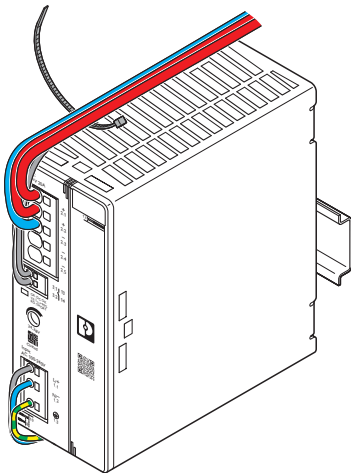

4. Arrange the connecting cables and use the cable ties to secure the bundled connecting cables.



NOTE: Avoid damage to the connecting cables caused by crushing

When securing the connecting cables with cable ties, make sure that the cables are properly secured and cannot move about. When doing so, make sure not to damage the insulation of the connecting cables.

Figure 34 Bundling and securing the connecting cables

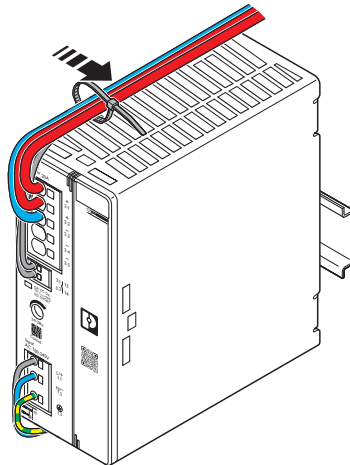

5. Then check again that the connecting cables are fixed securely
6. Remove any excess of the cable tie

Figure 35 Remove any excess of the cable tie

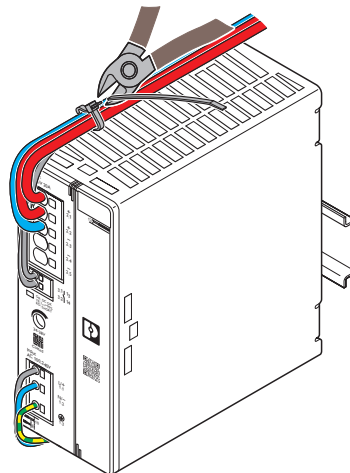

10 Function elements

The functional elements of the power supply are located on the front of the housing of the power supply and are categorized as follows:

- Operating element
- Indication element

10.1 Operating element – potentiometer U_{Out}

The power supply is operated via a stepless potentiometer on the device front. You can use the potentiometer to set the necessary output voltage for supplying the DC load. The axis of the potentiometer has a groove that is marked with an arrow. Turning the potentiometer clockwise increases the output voltage. Turning the potentiometer counter-clockwise decreases the output voltage. The angle of rotation of the potentiometer setting range ($U_{Out\ min}$ to $U_{Out\ max}$) is approx. 270° .

Figure 36 Position of the potentiometer

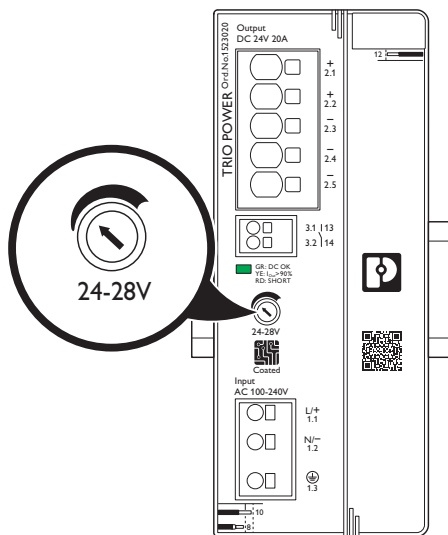

10.1.1 Sealing plug (optional)

As protection against manipulation (adjustment of the DC output voltage), you can close off the potentiometer opening with a sealing plug that is available as an option. The sealing plug has a hole on the back which, when plugged in, encloses the potentiometer axis. Push the sealing plug into the potentiometer opening until it closes off flush with the housing front (see section: Ordering data, accessories).

Figure 37 Inserting sealing plug

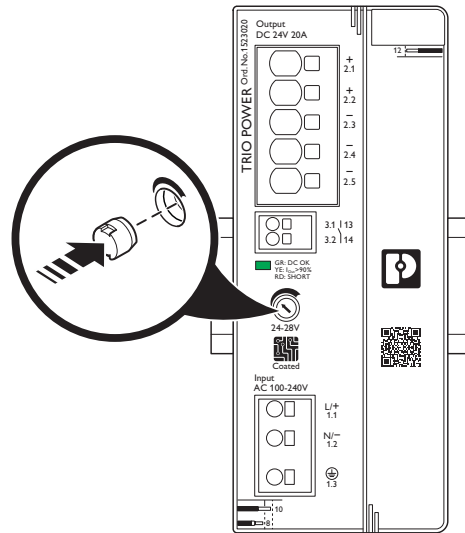

10.2 Indication element – DC OK LED (multicolor LED)

A DC OK LED is available for visual and preventive function monitoring of the power supply. The DC OK LED is a multicolor LED and indicates three basic operating states of the power supply.

Figure 38 Position of the DC OK LED (multicolor LED)

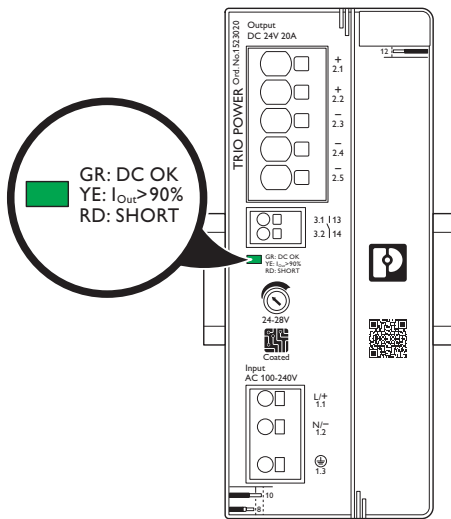

Figure 39 Signal states of the DC OK LED (multicolor LED)



For the color-coded assignment of the multicolor LED to the relevant operating state of the power supply, refer to the following table:

Multi-color LED	Color	Description
○	without	Primary-side AC supply is not available or too low.
●	green	Power supply in normal operation $U_{Out} > 0.9 \times U_N$ ($U_N = 24 \text{ V DC}$)
●	yellow	Power supply in normal operation, however the pre-alarm threshold $I_{Out} > 0.9 \times I_N$ ($U_N = 24 \text{ V DC}$) has been exceeded.
●	red	Impermissibly high load on the power supply or short circuit detected on the DC output side.
⊛		An impermissibly high DC voltage has been detected. The device-internal OVP (overvoltage protection) has been triggered.

Key:

○ = off, ● = on, ⊛ = flashing

11 Output characteristic curves



CAUTION: Hot surface

Depending on the ambient temperature and load on the power supply, the housing can become hot.

In normal operation, the power supply constantly supplies the output power in accordance with the device nominal data. On the device side, the dynamic boost is regarded as an extended operating characteristic of normal operation.

The power supply provides the following operating characteristics depending on the load:

- Normal operation/dynamic boost
- U/I mode
- HICCUP mode

Figure 40 Output characteristic curves depending on the DC load behavior

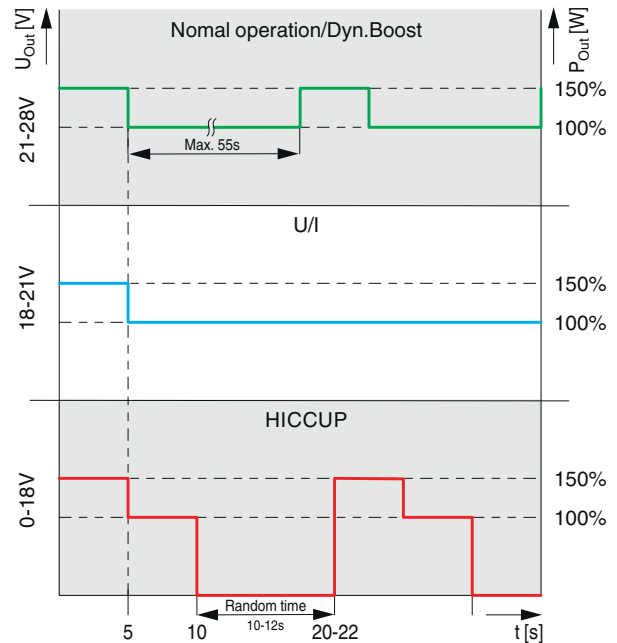

11.1 Normal operation/dynamic boost

In normal operation, the power supply supplies a DC output voltage that is within the voltage range from $\geq 21\text{ V DC} \dots < 28\text{ V DC}$ on the load side.

If the DC output current supplying the loads increases due to increased current consumption ($I_{\text{Out}} > I_N$), the power supply switches to the dynamic boost.

This operating behavior can occur, for example, when starting up a DC drive or when DC loads are connected in parallel. At that moment, the power supply provides additional power of up to 150% of the nominal power for max. 5 s.

The multicolor LED indicates the current consumption ($I_{\text{Out}} > 90\%$) and lights up yellow. If the mean value of the output current is greater than 90% for 60 seconds, the floating switch contact (13/14) opens (see section: Function elements, indication element - DC OK LED).

The maximum available dynamic boost time is directly dependent on the required additional power and can be calculated for the specific application (see section: Example: Boost capability and recovery time).



If the AC input voltage being supplied during normal operation falls to a value $< 100\text{ V AC}$, the dynamic boost operating characteristic is no longer possible.



Observe the maximum output ratings of the power supply. The average output power must not exceed nominal power limit (P_N).

11.1.1 Boost capability and recovery time

Depending on the DC load to be supplied, the max. boost time (t_{Boost}) and the corresponding required recovery time (t_{Recovery}) need to be calculated for the power supply.

The following data is used as the calculation basis for determining the boost time (t_{Boost}) and the recovery time (t_{Recovery}):

Figure 41 General representation and calculation basis, dynamic boost

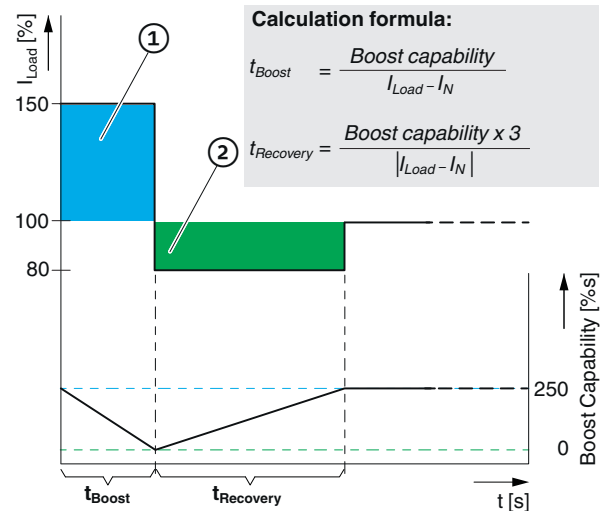

- ① = Boost capability: $50\% \times 5\text{ s} = 250\% \text{ s}$
For $I_{\text{out}} > I_N$: Boost capability is reduced
- ② = For $I_{\text{out}} < I_N$: Boost capability is gained by Factor 3

Key:

Designation	Description
t_{Boost}	Min. time [s] within which the boost current is supplied
I_{Boost}	Max. expected boost current (100% ... 150%)
I_N	Nominal current of the power supply (100%)
Boost Capability	Max. boost capability [%s]
t_{Recovery}	Recovery time [s]

11.1.2 Example: Calculation of t_{Boost} , $t_{Recovery}$

The following example illustrates the formulas that can be used in principle to calculate t_{Boost} and $t_{Recovery}$. In this example, it is assumed that your application uses the maximum additional power of 50% for the minimum dynamic boost time (5 s).

Assumptions for the calculation

Max. boost capability: 250%
 $\Delta I_{Boost} (max)$ for $I_N (100\%) = 50\%$: $I_N \times 1.5$
 I_{Out} in normal operation, 80%: $I_N \times 0.8$

Calculated values

t_{Boost} : 5 s
 $t_{Recovery}$: 37.5 s

Sample calculation:

$$t_{Boost} = \frac{250\%s}{150\% - 100\%} = 5\text{ s}$$

$$t_{Recovery} = \frac{250\%s \times 3}{180\% - 100\%} = 37,5\text{ s}$$

11.2 U/I mode

When the DC output voltage of the power supply is driven into the voltage range <21 V DC ... ≥18 V DC on the load side, the power supply switches to U/I mode. The DC load supply then follows the U/I output characteristic curve. In U/I mode, sustained power drain is limited to 100%.

At the same time, the multicolor LED indicates the detected operating state for the DC load supply. The DC OK LED (red) is activated and the floating switch contact (13/14) is open (see section: Function elements, indication element - DC OK LED).

11.3 HICCUP mode

If, for example, a malfunction on the load side causes the DC voltage on the output side to fall below the threshold value $U_N/3/4$ ($U_N = 24\text{ V DC}$), HICCUP mode starts.

In HICCUP mode, the power supply tries to restore the DC load supply on the output side. The characteristic of the HICCUP output characteristic curve reduces the thermal load of the connecting cables on the output side due to sustained overload.

This procedure is repeated until the cause of the current increase, e.g., overload or short circuit, has been remedied.

The power supply then switches the DC output on again and the DC load is supplied.

At the same time, the multicolor LED indicates the detected operating state for the DC load supply, SHORT (red) or $I_{Out} > 90\%$ (yellow), (see section: Function elements, indication element - DC OK LED)

Figure 42 Schematic diagram of HICCUP output characteristic curve

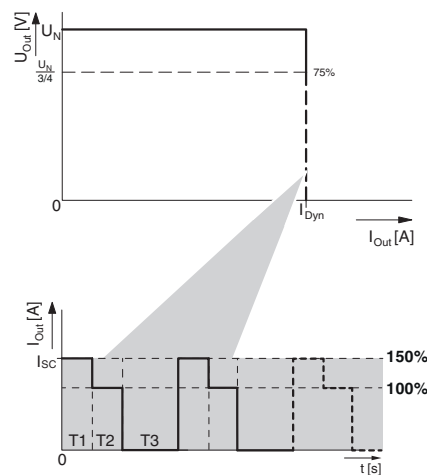

Key:

Designation	Value	HICCUP description
I_{sc}	max. 30 A	Maximum output current (short-circuit current)
T1	5 s	Pulse time (ON) at I_{sc} (150%)
T2	5 s	Pulse time (ON) at I_N (100%)
T3	10 ... 12 s	Variable recovery time (OFF)

12 Connection versions

Depending on how you intend to use your power supply, there are different ways of connecting the DC output side.

A distinction is made between the following modes of use:

- Power increase
- Redundancy operation

12.1 Increasing power

Depending on the respective mode of use, the power is increased either via the series- or parallel connection of two power supplies.

12.1.1 Series operation

To increase the DC output power in dependence of the output voltage, connect two power supplies in series operation. Only use power supplies of the same type and performance class with identical configurations.

Depending on the common output-side ground reference point of the power supplies, the following DC output voltage potentials are possible:

- +48 V DC
- -48 V DC
- ±24 V DC

Figure 43 Schematic diagram, power increase in series operation

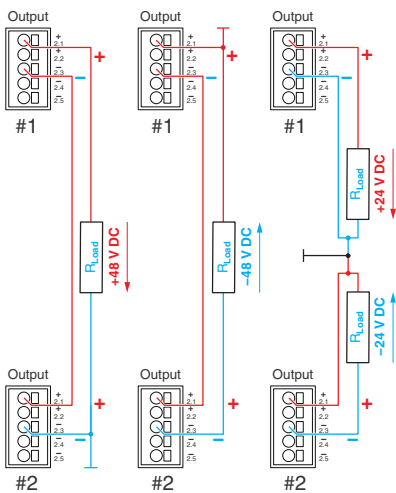

12.1.2 Parallel operation

When n power supply DC outputs are connected in parallel, the output current is increased to $n \times I_N$. Parallel connection for increased power is used when extending existing systems. If the individual power supply does not cover the current consumption of the most powerful load, parallel connection of power supplies is recommended.



Fundamental prerequisites apply for the parallel operation of power supplies. For further information, refer to section: Fundamental prerequisites for parallel operation (power increase, redundancy operation)

Figure 44 Schematic diagram, power increase in parallel operation

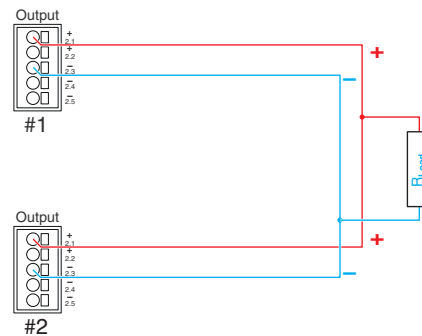

12.2 Redundant operation

Redundant circuits are suitable for the DC supply of systems and system parts which place particularly high demands on operational safety. If the DC load is to be supplied with 1+1 redundancy, two power supplies of the same type and performance class with identical configurations must be used.

In the event of an error, it must be ensured that one of the power supplies is able to provide the total required output power for the DC load to be supplied. The output power required for normal operation is thus provided by two power supplies connected in parallel on the output side. In normal operation, each of the two power supplies will be utilized by up to 50%.



A suitable selection of redundancy modules (active or passive) is to be found in the section: Ordering data, Accessories.

Figure 45 Schematic diagram, 1+1 redundancy with redundancy module (active or passive)

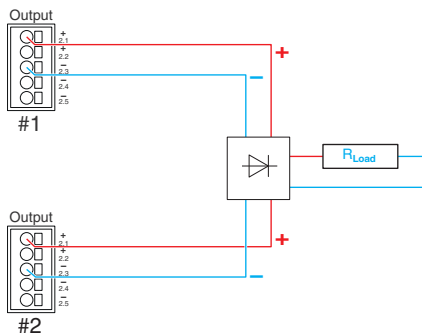

12.3 Fundamental prerequisites for parallel operation (power increase, redundancy operation)

In order to ensure correct parallel operation, observe the following rules:

DC output voltage: On each of the power supplies, set the DC voltage in idle mode such that the voltage values are identical. Take any voltage drops occurring due to long cable lengths into consideration.

Cable lengths: To ensure the symmetrical utilization of the power supplies, the connecting cables for supplying the DC load must be identical in length.

Cable cross sections: The connecting cables for supplying the DC load must be rated for the maximum occurring total current of all power supplies. This also applies for redundancy operation, whereby the individual power supply only supplies 50% of the DC load.

Ambient conditions: Select the installation location of the power supplies such that the prevailing ambient conditions are identical. This is of particular importance if the power supplies are installed in different mounting locations. Large temperature differences between the mounting locations have a negative effect on the operating points of the power supplies. This will result in the operating behavior of the power supplies no longer being identical.



If more than two power supplies are connected in parallel for the required power increase, fusing the DC outputs separately is recommended. Use appropriate miniature circuit breakers (MCBs) for this. As an alternative, the DC outputs can be decoupled from one another using redundancy modules (active or passive).

13 Derating

13.1 Ambient temperature

When mounted in the standard mounting position and operated within the permissible temperature range for nominal operation, the power supply provides full output power. If the power supply is operated beyond the temperature range for nominal values, note the reduced output power for the supply of DC loads.



NOTE: Damage due to thermal overload

If the power supply is operated in a different temperature range, only a reduced amount of power can be drawn. Otherwise, the power supply will be thermally loaded disproportionately and the device service life significantly reduced. This thermal load may even damage the power supply such that it is no longer operational.

Figure 46 Output power depending on the ambient temperature

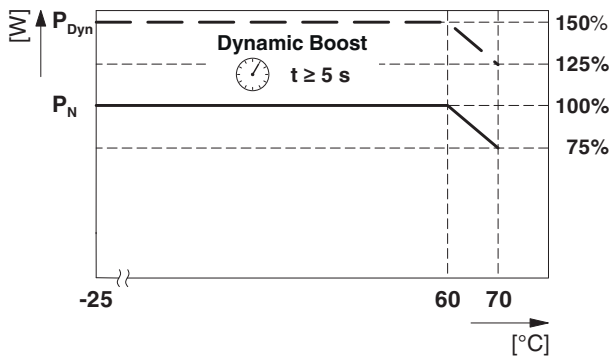

13.2 Installation height

The power supply can be operated at an installation height of up to 2000 m without any limitations. Different data applies for installation locations above 2000 m due to the differing air pressure and the reduced convection cooling associated with this.

Figure 47 Output power depending on the installation height

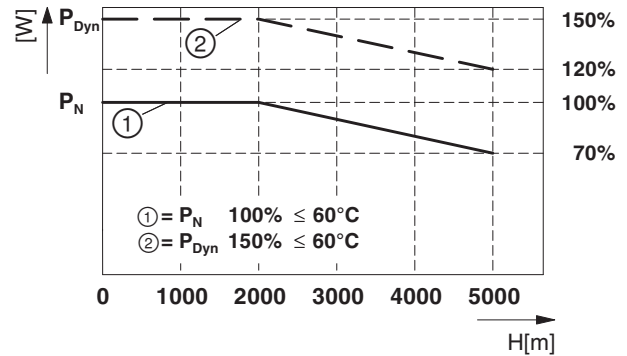

13.3 Position-dependent derating

In order that you can use the nominal power of the power supply without limitation, the power supply should always be mounted in the standard mounting position. Sufficient device-side convection is always assured if the power supply is mounted in the standard mounting position and the necessary restricted areas are observed.



NOTE: Damage due to thermal overload

If the supply is mounted in a different mounting position, only a reduced amount of power can be drawn. Otherwise, the power supply will be thermally loaded disproportionately and the device service life significantly reduced.

13.3.1 Normal mounting position

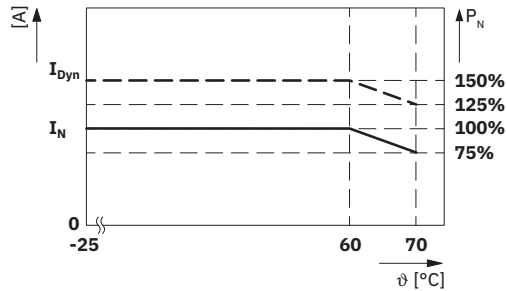
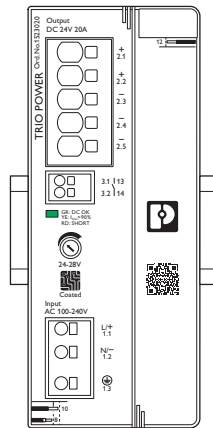
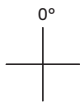

13.3.2 Rotated mounting position 90° Z-axis

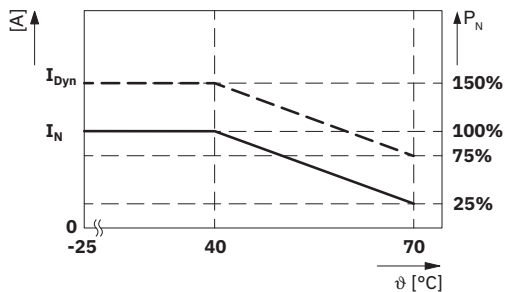
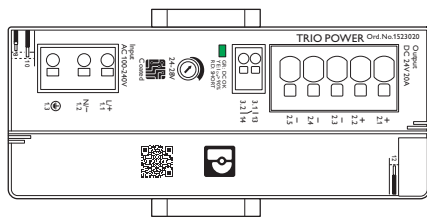
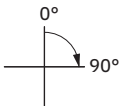

13.3.3 Rotated mounting position 180° Z-axis

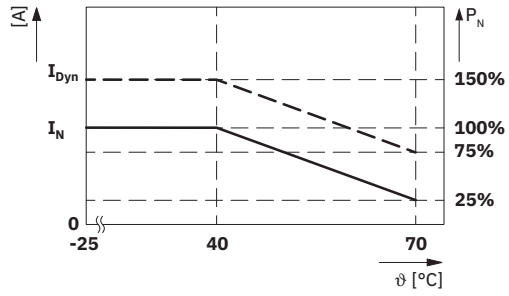
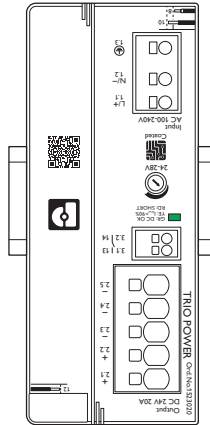
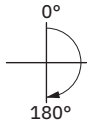

13.3.4 Rotated mounting position 270° Z-axis

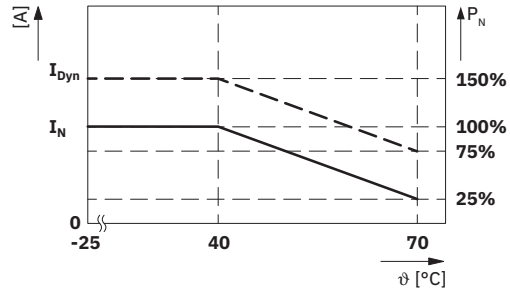
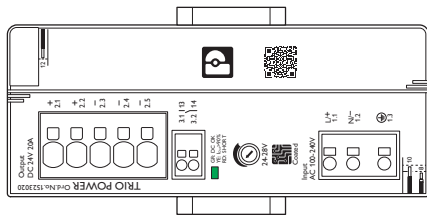
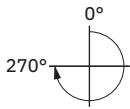

13.3.5 Rotated mounting position 90° X-axis

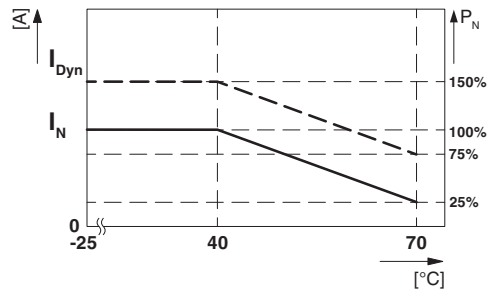
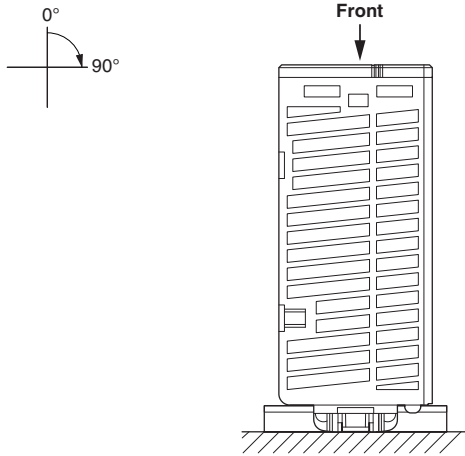

13.3.6 Rotated mounting position 270° X-axis

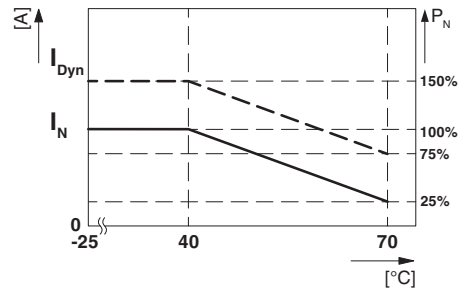
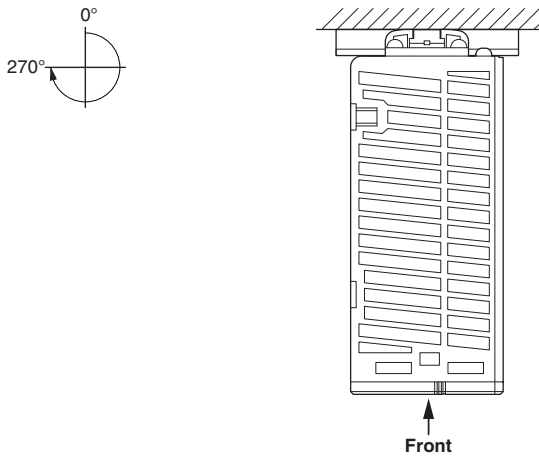

14 Disposal and recycling



Ensure the correct disposal of electronic components

Do not dispose of the power supply as household waste.
Observe the applicable national standards and regulations.



Ensure correct disposal or recycling

Dispose of or recycle packaging material that is no longer needed as household waste.
Observe the applicable national standards and regulations.

15 Help with technical questions



Should you have any technical questions, you can contact our Support team
E-mail: de-ps-support@phoenixcontact.com