

UNO2-PS/1AC/48DC/240W

Power supply unit



Data sheet

109641_en_00

© Phoenix Contact

2023-10-05

1 Description

The UNO POWER power supply features maximum energy efficiency and can be used anywhere in the world.

Thanks to its high power density, the UNO POWER power supply unit is the ideal solution, particularly in compact applications.

Space-saving

- Particularly compact design
- 480 W nominal power with an overall width of 59 mm
- Alignable without minimum clearance to neighboring modules

Flexible use

- Large, wide-range input of the AC supply voltage
- Adjustable DC output voltage
- Reliable device startup, even at -40°C
- Efficiency up to 94.6%

Easy system diagnostics

- DC OK LED
- Floating switch contact

Technical data (short form)

Input voltage range	100 V AC ... 240 V AC - 15 % ... +10 %
Mains buffering time	typ. 20 ms (120 V AC) typ. 20 ms (230 V AC)
Nominal output voltage (U_N)	48 V DC
Setting range of the output voltage (U_{Set})	42 V DC ... 56 V DC
Nominal output current (I_N)	5 A
Output power (P_N)	240 W
Efficiency (for nominal values)	typ. 91.5 % (120 V AC) typ. 93 % (230 V AC)
Residual ripple	typ. 50 mV _{pp}
MTBF (IEC 61709, SN 29500)	230 V AC / > 1000000 h (25 °C) 230 V AC / > 550000 h (40 °C) 230 V AC / > 280000 h (55 °C)
With protective coating	No
Ambient temperature (operation)	-25 °C ... 70 °C (> 55 °C Derating: 2.5 %/K)
Startup type tested	-40 °C
Dimensions (W x H x D)	45 x 130 x 129 mm
Weight	855 g



All technical specifications are nominal and refer to a room temperature of 25 °C and 70 % relative humidity at 100 m above sea level.

2	Table of contents	
1	Description	1
2	Table of contents	2
3	Ordering data	3
4	Technical data	4
5	Safety and installation notes	12
6	High-voltage test (HIPOT)	13
7	Design	14
8	Mounting/remove.....	17
9	Device connection terminal blocks	19
10	Function elements	22
11	Output characteristic curves	23
12	Connection versions	23
13	Derating.....	25
14	Disposal and recycling.....	29

3 Ordering data

Description	Type	Item no.	Pcs./Pkt.
Primary-switched power supply unit, UNO POWER, Screw connection, DIN rail mounting, input: 1-phase, output: 48 V DC / 5 A, Adjustable from 42 V DC ... 56 V DC	UNO2-PS/1AC/48DC/240W	1110155	1
Accessories	Type	Item no.	Pcs./Pkt.
Redundancy module TRIO DIODE, Screw connection, DIN rail mounting, output: 47.3 V DC / 20 A	TRIO-DIODE/48DC/2X10/1X20	2866527	1
Type 2/3 surge protection, consisting of protective plug and base element with screw connection. For single-phase power supply network with integrated status indicator and remote signaling. Nominal voltage: 230 V AC/DC	PLT-SEC-T3-230-FM-UT	2907919	5
Type 2/3 surge protection, consisting of protective plug and base element with Push-in connection. For single-phase power supply network with integrated status indicator and remote signaling. Nominal voltage: 230 V AC/DC	PLT-SEC-T3-230-FM-PT	2907928	5



You will find the latest accessories for the item at [phoenixcontact.com/products](https://www.phoenixcontact.com/products).

4 Technical data

Input data



Unless otherwise stated, all data applies for 25°C ambient temperature, 230 V AC input voltage, and nominal output current (I_N).

Input voltage range	100 V AC ... 240 V AC -15 % ... +10 %
Derating < 90 V AC	1 %/V
Frequency range (f_N)	50 Hz ... 60 Hz \pm 10 %
Typical national grid voltage	120 V AC / 230 V AC
Network type	Star network (TN, TT, IT (PE))
Current consumption 100 V AC / 240 V AC 120 V AC / 230 V AC	2.6 A / 1.2 A 2.2 A / 1.16 A
Discharge current to PE	< 3.5 mA
Mains buffering time 120 V AC / 230 V AC	typ. 20 ms / typ. 20 ms
Switch-on time	typ. 530 ms
Inrush current (at 25 °C)	typ. 10 A
Inrush current integral (I^2t)	< 0.05 A ² s
Device mains fuse , internal (device protection), fast-blow	5 A



During the first few microseconds, the current flow into the filter capacitors is excluded.



The SCCR (short-circuit current rating) value of the power supply unit corresponds to the SCCR value of the backup fuse.

Input protection, AC (to be connected externally upstream)

Input current I_{IN} Input protection	Circuit breaker					Neozed fuse or equivalent gG	Power switch $\leq 13 \times I_{IN}$ (maximum magnetic tripping)
	A	B	C	D	K		
4 A	-	-	-	-	-	✓	-
6 A	-	✓	✓	✓	✓	✓	-
10 A	-	✓	✓	✓	✓	✓	✓
13 A	-	✓	✓	✓	✓	✓	✓
16 A	-	✓	✓	✓	✓	✓	✓

Protective circuit

Type of protection	Transient surge protection
Protective circuit/component	Varistor, gas-filled surge arrester

Electric strength of the insulation

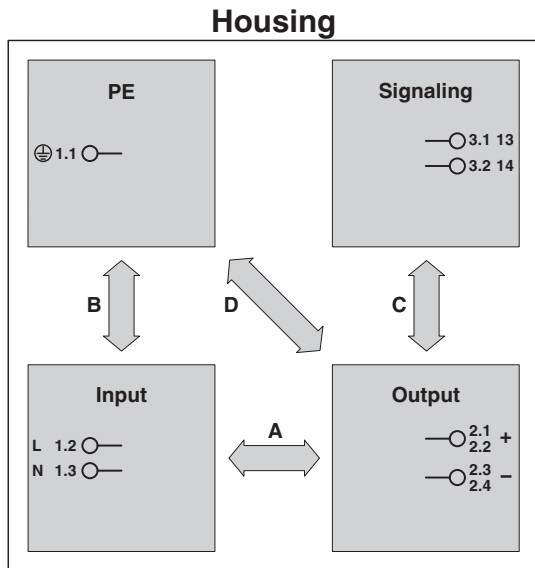

Test voltage	A	B	C	D
Type test (IEC/EN 61010-1)	3 kV AC	1.5 kV AC	--	--
Production test	2.5 kV AC	2.2 kV AC	0.5 kV AC	1.5 kV AC
Field test (with gas-filled surge arrester)	1.1 kV AC	1.1 kV AC	--	--

POWER factor

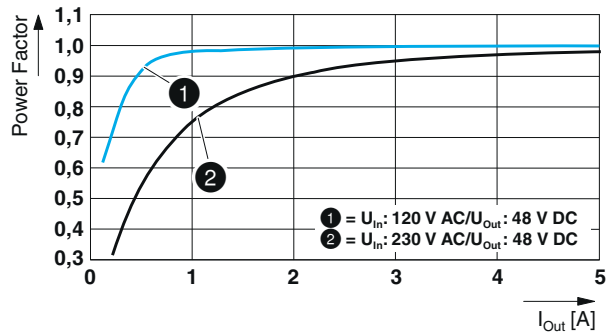

Crest factor	120 V AC	230 V AC
	typ. 1.637	typ. 1.54

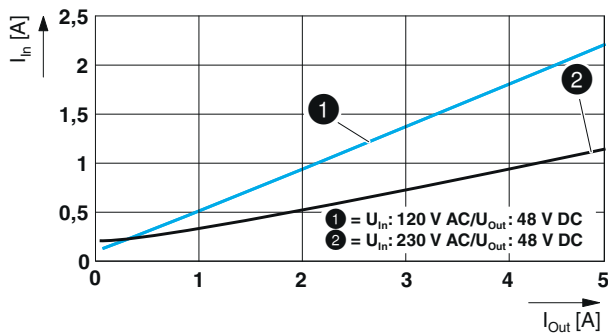
Input current vs. output current

Connection data: Input

Position	1.x
Connection method	Screw connection
Drive form screw head	Slotted L
Stripping length	6.5 mm
Tightening torque	0.5 Nm ... 0.6 Nm / 4 lb _f -in. ... 5 lb _f -in.
1-conductor rigid	0.2 mm ² ... 2.5 mm ²
1-conductor flexible	0.2 mm ² ... 2.5 mm ²
1-conductor flexible with ferrule without plastic sleeve	0.25 mm ² ... 2.5 mm ²
1-conductor flexible with ferrule with plastic sleeve	0.25 mm ² ... 2.5 mm ²
1-conductor rigid (AWG) (Cu)	24 ... 14

Output data

Nominal output voltage (U_N)	48 V DC
Setting range of the output voltage (U_{Set}) $\geq 48 \text{ V DC}$, constant capacity restricted $< 48 \text{ V DC}$, constant current restricted	42 V DC ... 56 V DC
Nominal output current (I_N)	5 A
Output power (P_N)	240 W
Control deviation	
change in load, static 10 % ... 90 %	< 1 %
change in load, dynamic 10 % ... 90 %	< 3 %
change in input voltage $\pm 10 \%$	< 0.1 %
Short-circuit-proof	yes
No-load proof	yes
Residual ripple	typ. 50 mV _{PP}
Connection in parallel	yes, for redundancy
Connection in series	yes, for increased output voltage
Feedback voltage resistance	$\leq 60 \text{ V DC}$
Protection against overvoltage at the output (OVP)	$\leq 60 \text{ V DC}$
Rise time	
$U_{Out} = 10 \% \dots 90 \%$	< 1 s

Connection data: Output

Position	2.x
Connection method	Screw connection
Drive form screw head	Slotted L
Stripping length	6.5 mm
Tightening torque	0.5 Nm ... 0.6 Nm / 4 lb _f -in. ... 5 lb _f -in.
1-conductor rigid	0.2 mm ² ... 2.5 mm ²
1-conductor flexible	0.2 mm ² ... 2.5 mm ²
1-conductor flexible with ferrule without plastic sleeve	0.25 mm ² ... 2.5 mm ²
1-conductor flexible with ferrule with plastic sleeve	0.25 mm ² ... 2.5 mm ²
1-conductor rigid (AWG) (Cu)	24 ... 14

DC OK LED - signal state operation (U_N = 48 V DC, I_{Out} = I_N)

Function	Visual operating state display
Color	green
LED Off	Supply voltage input AC not present
LED On (green), DC OK	U _{OUT} ≥ 0.9 x U _N (U _N = 48 V DC)
LED on (flashing green)	U _{OUT} > 60 V DC

DC OK switch contact - signal state operation (U_N = 48 V DC, I_{Out} = I_N)

Connection level	3.x
Connection labeling	3.1 (13), 3.2 (14)
Function	Operating state forwarding
Switch contact (floating)	OptoMOS
Switching voltage	max. 30 V AC/DC / max. 60 V DC
Current carrying capacity	max. 50 mA
State condition	
Contact closed	U _{OUT} ≥ 0.9 x U _N (U _N = 48 V DC)
Contact open	U _{OUT} < 42 V DC
Contact open	U _{OUT} > 60 V DC

Connection data: Signal

Position	3.x
Connection method	Screw connection
Drive form screw head	Slotted L
Stripping length	6.5 mm
Tightening torque	0.5 Nm ... 0.6 Nm / 4 lb _f -in. ... 5 lb _f -in.
1-conductor rigid	0.2 mm ² ... 2.5 mm ²
1-conductor flexible	0.2 mm ² ... 2.5 mm ²
1-conductor flexible with ferrule without plastic sleeve	0.25 mm ² ... 2.5 mm ²
1-conductor flexible with ferrule with plastic sleeve	0.25 mm ² ... 2.5 mm ²
1-conductor rigid (AWG) (Cu)	24 ... 14

Reliability	25 °C	40 °C	55 °C
MTBF (IEC 61709, SN 29500)			
230 V AC	> 1000000 h	> 550000 h	> 280000 h

General data	
Degree of protection	IP20
Protection class	I
With protective coating	No
Flammability rating UL 94	
Housing, terminal blocks	V0
Housing material	Aluminum (AlMg3) / sheet steel, zinc-plated
Foot latch material	Sheet steel, zinc-plated
Dimensions (W x H x D)	45 x 130 x 129 mm
Device depth (DIN rail mounting)	125 mm
Weight	855 g

Power dissipation	120 V AC	230 V AC
No load	< 2.9 W	< 3 W
Nominal load	< 23 W	< 19 W

Efficiency	120 V AC	230 V AC
	typ. 91.5 %	typ. 93 %

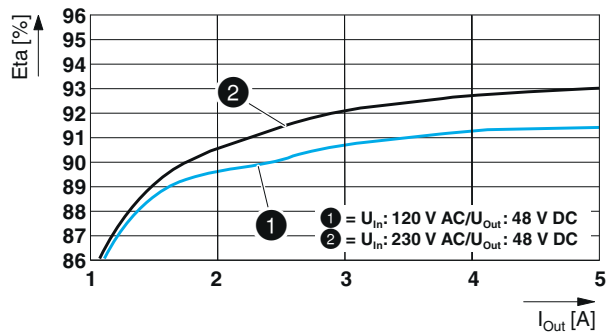

Ambient conditions

Ambient temperature (operation) -25 °C ... 70 °C (> 55 °C Derating: 2.5 %/K)



The ambient temperature (operation) refers to IEC 61010 surrounding air temperature.

Ambient temperature (start-up type tested) -40 °C

Ambient temperature (storage/transport) -40 °C ... 85 °C

Max. permissible relative humidity (operation) ≤ 95 % (at 25 °C, non-condensing)

Installation height ≤ 3000 m (> 2000 m, Derating: 10 %/1000 m)

Vibration (operation) 10 Hz ... 50 Hz, amplitude ±0.2 mm
50 Hz to 150 Hz, 2.3 g, 90 min.

Shock (operation) IEC 60068-2-27 18 ms, 30g, per spatial direction

Degree of pollution 2

Climate class EN 60721 3K22

Overvoltage category EN 61010-1 II (≤ 3000 m)
EN 62477-1 III (≤3000 m)

Standards/specifications

Safety of power supply units up to 1100 V (insulation distances) DIN EN 61558-2-16

Electrical safety IEC 61010-2-201 (SELV)

Equipping high voltage installations with electronic equipment EN 50178/VDE 0160 (PELV)

Safety for equipment for measurement, control, and laboratory use IEC 61010-1

Protective extra-low voltage IEC 61010-1 (SELV) IEC 61010-2-201 (PELV)

Safe isolation IEC 61558-2-16 IEC 61010-2-201

Limitation of harmonic line currents EN 61000-3-2

Requirement of the semiconductor industry with regard to mains voltage dips SEMI F47 - 0706 (185 V AC)

Conformance/Approvals

UL UL/C-UL Listed UL 61010-1
UL/C-UL Listed UL 61010-2-201
UL/C-UL Listed ANSI/UL 121201 Class I, Division 2, Groups A, B, C, D (Hazardous Location)

SIQ CB scheme (IEC 61010-1, IEC 61010-2-201)

Temperature class (ANSI/UL 121201)

Temp code T4 (-25°C ... +70°C; >55°C, derating: 2.5 %/K)



You will find the latest approvals for the item at phoenixcontact.com/products.

Electromagnetic compatibility		
Conformance with EMC Directive 2014/30/EU		
Interference emission in accordance with EN 61000-6-3 (residential and commercial) and EN 61000-6-4 (industrial)		
CE basic standard	Minimum normative requirements	Higher requirements in practice (covered)
Conducted noise emission EN 55016	EN 61000-6-4 (Class A)	EN 61000-6-3 (Class B)
Noise emission EN 55016	EN 61000-6-4 (Class A)	EN 61000-6-3 (Class B)
Harmonic currents EN 61000-3-2	EN 61000-3-2 (Class A)	EN 61000-3-2 (Class A)
Flicker EN 61000-3-3	not required	0 kHz ... 2 kHz
EN 61000-6-2:2005		
CE basic standard	Minimum normative requirements of EN 61000-6-2 (CE)	Higher requirements in practice (covered)
Electrostatic discharge EN 61000-4-2		
Housing contact discharge	4 kV (Test Level 2)	6 kV (Test Level 3)
Housing air discharge	8 kV (Test Level 3)	8 kV (Test Level 3)
Comments	Criterion B	Criterion A
Electromagnetic HF field EN 61000-4-3		
Frequency range	80 MHz ... 1 GHz	80 MHz ... 1 GHz
Test field strength	10 V/m (Test Level 3)	10 V/m (Test Level 3)
Frequency range	1.4 GHz ... 6 GHz	1 GHz ... 6 GHz
Test field strength	3 V/m (Test Level 2)	10 V/m (Test Level 3)
Comments	Criterion A	Criterion A
Fast transients (burst) EN 61000-4-4		
Input	2 kV (Test Level 3 - asymmetrical)	4 kV (Test Level 4 - asymmetrical)
Output	1 kV (Test Level 2 - asymmetrical)	2 kV (Test Level 3 - asymmetrical)
Comments	Criterion B	Criterion A
Surge voltage load (surge) EN 61000-4-5		
Input	1 kV (Test Level 3 - symmetrical) 2 kV (Test Level 3 - asymmetrical)	2 kV (Test Level 4 - symmetrical) 4 kV (Test Level 4 - asymmetrical)
Output	0.5 kV (Test Level 2 - symmetrical) 1 kV (Test Level 2 - asymmetrical)	1 kV (Test Level 3 - symmetrical) 2 kV (Test Level 3 - asymmetrical)
Comments	Criterion B	Criterion A

EN 61000-6-2:2005			
CE basic standard		Minimum normative requirements of EN 61000-6-2 (CE)	Higher requirements in practice (covered)
Conducted interference EN 61000-4-6			
	Input/output	asymmetrical	asymmetrical
	Frequency range	0.15 MHz ... 80 MHz	0.15 MHz ... 80 MHz
	Voltage	10 V (Test Level 3)	10 V (Test Level 3)
	Comments	Criterion A	Criterion A
Voltage dips EN 61000-4-11			
Input voltage (230 V AC, 50 Hz)			
	Voltage dip	70 %, 25 periods (Test Level 2)	70 % , 25 / 30 periods
	Comments	Criterion A	Criterion A
	Voltage dip	40 %, 10 periods (Test Level 2)	40 %, 12 periods (Test Level 2)
	Comments	Criterion A	Criterion A
	Voltage dip	0 %, 1 period (Test Level 2)	0 %, 1 period (Test Level 2)
	Comments	Criterion B	Criterion B

Key

Criterion A	Normal operating behavior within the specified limits.
Criterion B	Temporary impairment to operational behavior that is corrected by the device itself.

5 Safety and installation notes

Symbols used

Instructions and possible hazards are indicated by corresponding symbols in this document.



This is the safety alert symbol. It is used to alert you to potential personal injury hazards. Obey all safety measures that follow this symbol to avoid possible personal injuries.

There are different categories of personal injury that are indicated by a signal word.



WARNING

This indicates a hazardous situation which, if not avoided, could result in death or serious injury.



CAUTION

This indicates a hazardous situation which, if not avoided, could result in minor or moderate injury.

The following symbols are used to indicate potential damage, malfunctions, or more detailed sources of information.



NOTE

This symbol together with the signal word NOTE and the accompanying text alert the reader to a situation which may cause damage or malfunction to the device, hardware/software, or surrounding property.



This symbol and the accompanying text provide the reader with additional information or refer to detailed sources of information.

Safety notes and warning instructions



WARNING: Danger to life by electric shock!

- Only skilled persons may install, start up, and operate the device.
- Never carry out work when voltage is present.
- Establish connection correctly and ensure protection against electric shock.
- Cover termination area after installation in order to avoid accidental contact with live parts (e. g., installation in control cabinet).



NOTE

- Observe the national safety and accident prevention regulations.
- Assembly and electrical installation must correspond to the state of the art.
- The power supply is a built-in device and is designed for mounting in a control cabinet.
- The IP20 degree of protection of the device is intended for use in a clean and dry environment.
- Observe mechanical and thermal limits.
- Horizontal mounting position (normal mounting position)
- Mount the power supply unit in the standard installation position. Position of the L/N connection terminal blocks at bottom.
- Make sure that the wiring on the primary side and the secondary side is adequately dimensioned and protected.
- For the connection parameters for wiring the power supply, such as the required stripping length with and without ferrule, refer to the technical data section.
- Use copper cables for operating temperatures of
>75 °C (ambient temperature <55 °C)
>90 °C (ambient temperature <75 °C).
- The power supply is approved for the connection to TN, TT and IT power grids (star networks) with a maximum phase-to-phase voltage of 240 V AC
- Protect the device against foreign bodies penetrating it, e.g., paper clips or metal parts.
- The power supply is maintenance-free. Repairs may only be carried out by the manufacturer. The warranty no longer applies if the housing is opened.
- The power supply may only be used for its intended use.

6 High-voltage test (HIPOT)

This protection class I power supply is subject to the Low Voltage Directive and is factory tested. During the HIPOT test (high-voltage test), the insulation between the input circuit and output circuit is tested for the prescribed electric strength values, for example. The test voltage in the high-voltage range is applied at the input and output terminal blocks of the power supply. The operating voltage used in normal operation is a lot lower than the test voltage used.



High-voltage tests can be performed as described.

The test voltage should rise and fall in ramp form. The relevant rise and fall time of the ramp should be at least two seconds.

6.1 High-voltage dielectric test (dielectric strength test)

In order to protect the user, power supplies (as electric components with a direct connection to potentially hazardous voltages) are subject to more stringent safety requirements. For this reason, permanent safe electrical isolation between the hazardous input voltage and the touch-proof output voltage as safety extra-low voltage (SELV) must always be ensured.

In order to ensure permanent safe isolation of the AC input circuit and DC output circuit, high-voltage testing is performed as part of the safety approval process (type test) and manufacturing (routine test).

6.2 High-voltage dielectric test during the manufacturing process

During the power supply manufacturing process, a high-voltage test is performed as part of the dielectric test in accordance with the specifications of IEC/UL/EN 61010-1. Routine manufacturing tests are inspected regularly by a certification authority.

6.3 High-voltage dielectric test performed by the customer

Apart from routine and type tests to guarantee electrical safety, the end user does not have to perform another high-voltage test on the power supply as an individual component. According to EN 60204-1 (Safety of machinery - Electrical equipment of machines) the power supply can be disconnected during the high-voltage test and only installed once the high-voltage test has been completed.

6.3.1 Performing high-voltage testing

If high-voltage testing of the control cabinet or the power supply as a stand-alone component is planned during final inspection and testing, the following features must be observed.

- The power supply wiring must be implemented as shown in the wiring diagram.
- The maximum permissible test voltages must not be exceeded.

Avoid unnecessary loading or damage to the power supply due to excessive test voltages.



For the relevant applicable test voltages and insulation distances, refer to the corresponding table (see technical data: electric strength of the insulation section).

Figure 1 Potential-related wiring for the high-voltage test

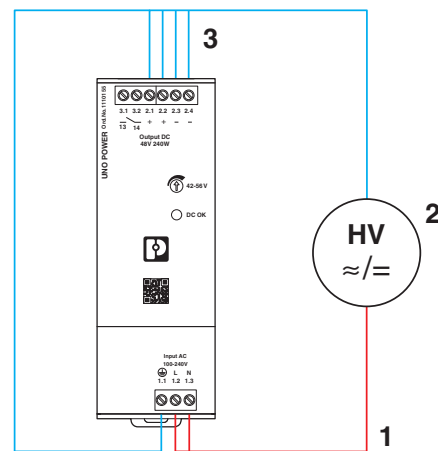

Key

No.	Designation	Color coding	Potential levels
1	AC input circuit	Red	Potential 1
2	High-voltage tester	--	--
3	DC output circuit	Blue	Potential 2

7 Design

7.1 Rating plate

In accordance with the German Product Safety Law (ProdSG) it is only permissible to make such products available on the market if they meet certain safety standards. It must be ensured at all times that users are not exposed to hazards.

In accordance with ProdSG, every device must therefore be fitted with a rating plate. All relevant information on the safe use of the device must also be included.



The power supply device rating plate is located on the right-hand side of the housing (as viewed from the front).

Figure 2 Rating plate information

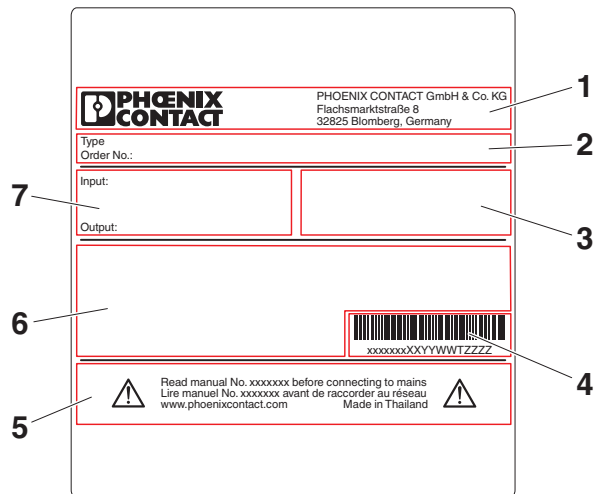

Key

No.	Designation
1	Identification of the provider
2	Product designation
3	Ambient conditions
4	Bar code and serial number for device identification
5	Designation of product-related device documentation
6	Device approvals
7	Device connection data

7.2 Device connections and functional elements

Device connections are labeled with connection tags to ensure clear and definitive identification.

The connection tags are split into the following connection levels:

Connection level	Description
1.x	Input
2.x	Output
3.x	Signal

Figure 3 Location of functional elements and device connections

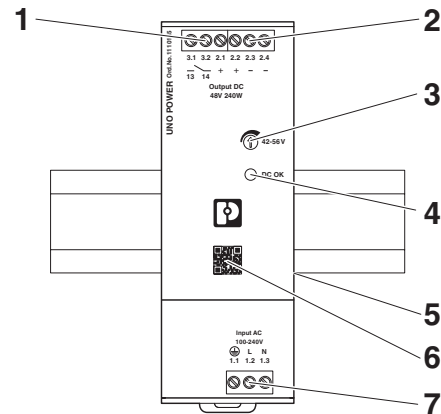

Key

No.	Designation	Connection labeling
1	Connection terminal blocks, floating switch contact (13/14)	3.1, 3.2
2	Connection terminal block output voltage: Output DC +/-	2.1 ... 2.4
3	Potentiometer output voltage	--
4	Signaling DC OK LED	--
5	Snap-on foot for DIN rail mounting	--
6	QR code web link	--
7	Connection terminal block input voltage: Input L/N/⊕	1.1 ... 1.3

7.3 Block diagram

Figure 4 Block diagram

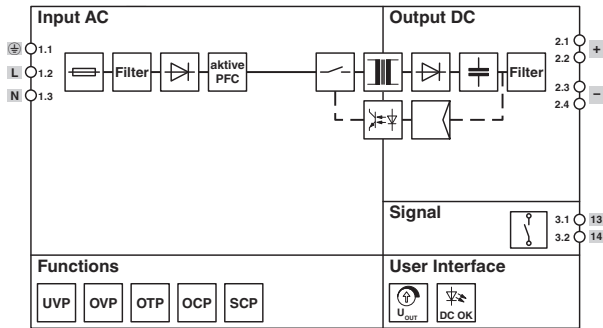

Key

Symbol	Designation – Input AC, Output DC
	Input fuse, internal device protection
Filter	EMC filter
	Rectification
aktive PFC	Power factor correction (PFC)
	Switching transistor
	Transmitter with electrical isolation
	Smoothing capacitor

Symbol	Designation – Functions
UVP	Undervoltage protection protects the AC input of the power supply against damage in the event of an AC undervoltage.
OVP	Overvoltage protection protects the DC output of the power supply and the connected load against damage in the event of an overvoltage
OTP	Overtemperature protection protects the power supply against damage in the event of impermissibly high intrinsic external heating.
OCP	Overcurrent protection protects the DC output of the power supply against damage in the event of an impermissibly high current load.
SCP	Short-circuit protection protects the DC output of the power supply against damage in the event of an output-side short circuit.

Symbol	Designation – Signal
	Floating switch contact (13/14) for forwarding the operational readiness to a superordinate control system.

Symbol	Designation – User interface
	Potentiometer for setting the output voltage U_{Out}
	DC OK LED, indicates the operating status of the power supply

7.4 Device dimensions

Figure 5 Device dimensions (dimensions in mm)

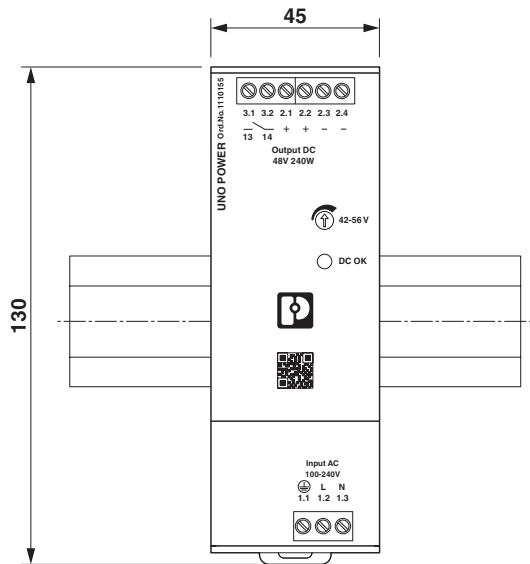
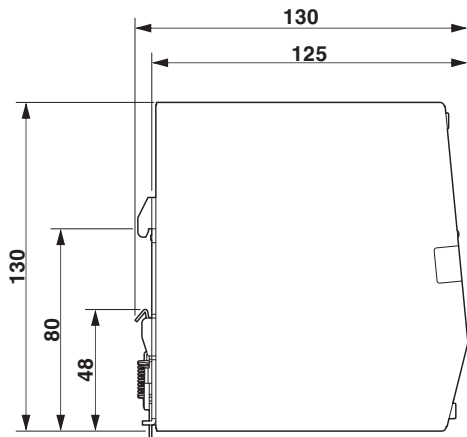

Figure 6 Device dimensions (dimensions in mm)



8 Mounting/remove

The fanless convection-cooled power supply can be snapped onto 35 mm DIN rails with a top hat profile (TH 35-7.5 / TH 35-15) in accordance with EN 60715.

8.1 Convection

To ensure sufficient convection, a minimum clearance is necessary between the power supply and above/below the installed devices. The minimum clearances are rated based on the standard mounting position with nominal power supply operation (see section: Restricted areas).

Figure 7 Schematic diagram of the convection cooling

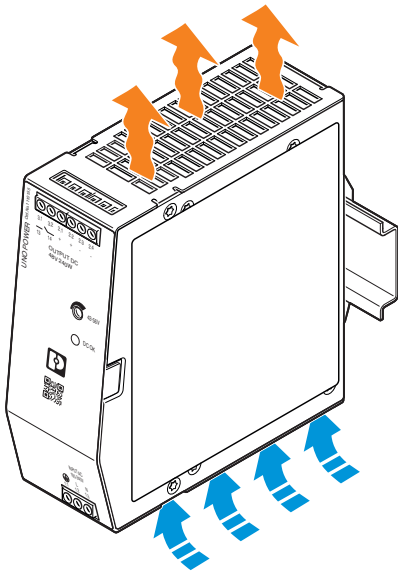

8.2 Mounting position

The specified technical data for the power supply is based on nominal operation in the standard mounting position. Any different technical data based on deviating mounting positions or other ambient conditions is labeled accordingly (see section: Derating).

Figure 8 Power supply installed in the normal mounting position

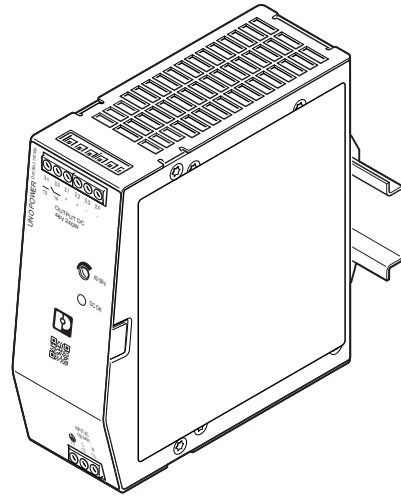

8.3 Installation height

You can operate the power supply without power limitations up to an installation altitude of 2000 m. For altitudes higher than 2000 m, different specifications apply due to the differing air pressure and the reduced convection cooling associated with this (see section: Derating).

8.4 Keep-out areas

Figure 9 Device dimensions and minimum keep-out areas (in mm)

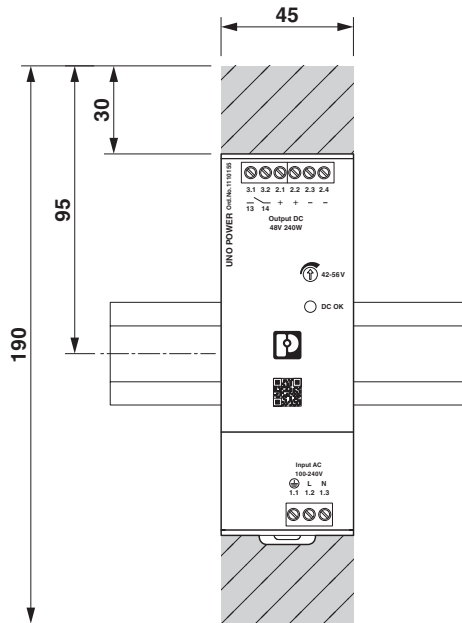

8.5 Mounting the power supply unit

Proceed as follows to mount the power supply:

1. In the standard mounting position, the power supply is mounted on the DIN rail from above. When doing so, ensure that the snap-on foot engages correctly behind the DIN rail (A).
2. Then press the power supply down until the snap-on foot audibly latches into place (B).
3. Check that the power supply is securely attached to the DIN rail.

Figure 10 Snapping the power supply onto the DIN rail

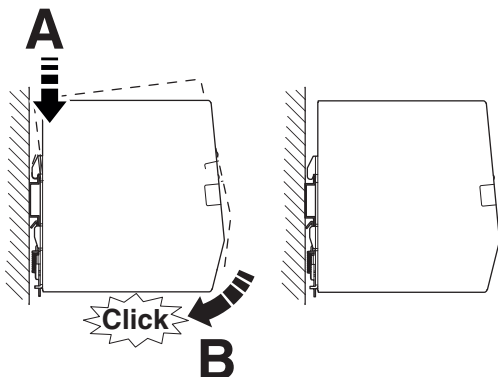

8.6 Removing the power supply unit

Proceed as follows to remove the power supply:

1. Take a suitable screwdriver and insert this into the latch opening on the snap-on foot (A).
2. Release the lock by lifting the screwdriver (B).
3. Carefully swivel the power supply forward (C) so that the lock slides back into the starting position.
4. Then separate the power supply from the DIN rail (D).

Figure 11 Removing the power supply from the DIN rail

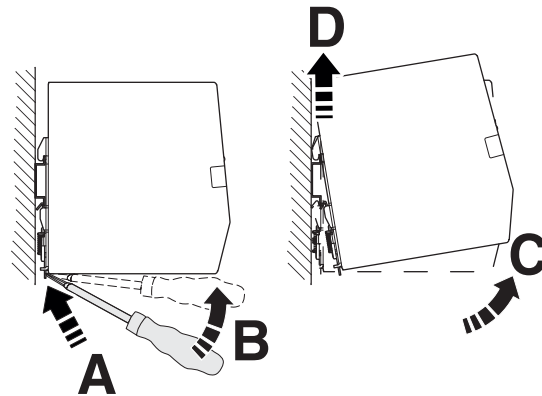

9 Device connection terminal blocks

The AC input, DC output, and signal terminal blocks on the front of the power supply feature screw connection technology.

i For the necessary connection parameters for the connection terminal blocks, refer to the technical data section.

9.1 AC input terminal blocks

The power supply is designed such that it can be operated on single-phase AC supply systems or on two phase conductors of three-phase systems. Here, the star supply system supports various supply system configurations, for example TT, TN, and IT systems.

The power supply is connected on the primary side via the Input AC connection terminal blocks (connection level 1.x, input).

i The power supply is approved for connection to TN, TT, and IT power grids with a maximum phase-to-phase voltage of 240 V AC.

Figure 12 Position of the AC input terminal blocks

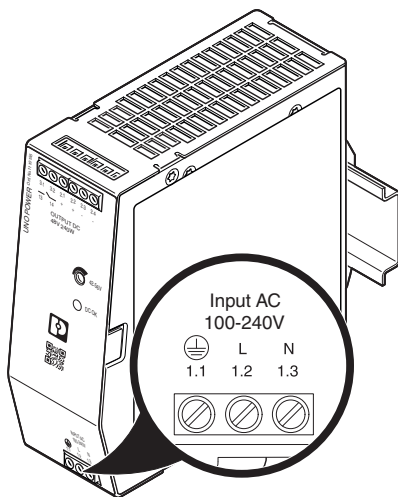

9.2 Protection of the primary side

The installation of the power supply must conform to the regulations of EN 61010. It must be possible to switch the power supply off using a suitable disconnection device outside of the power supply. The line protection on the primary side is suitable for this (see section: Technical data).

9.2.1 Fuse protection in a single-phase supply system

Figure 13 Schematic diagram, single-phase fuse protection

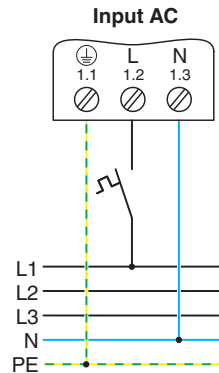

9.2.2 Fuse protection in a three-phase supply system



DANGER: Hazardous voltage

The primary-side fuse protection in two-phase operation must be cover all poles.

Figure 14 Schematic diagram, two-phase fuse protection

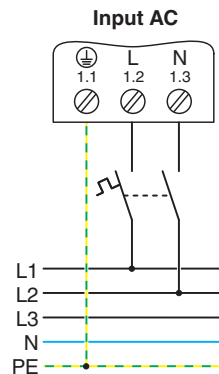

9.3 Supply system configurations and systems

9.3.1 Connection versions, single-phase supply system

The power supply is designed such that it can also be operated on two phase conductors of three-phase systems.

Figure 15 Wiring principle in a star supply system, single-phase operation

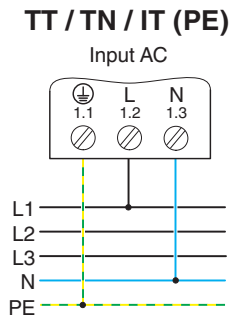

9.3.2 Connection versions, three-phase supply system



DANGER: Hazardous voltage

When operating the power supply on a three-phase system, observe the maximum permissible phase-to-phase voltage (see section: Technical data).

Figure 16 Wiring principle in a star supply system, two-phase operation

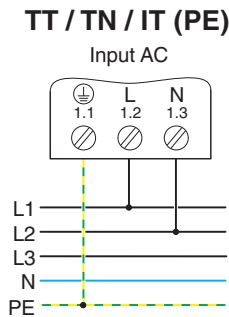

9.4 DC output terminal blocks

Connect the DC load to be supplied to the Output DC connection terminal blocks (connection level 2.x, output). By default, the power supply is preset to a nominal output voltage of 24 V DC. To compensate for a line-related voltage drop over long distances between the power supply and the DC load, you can adjust the DC output voltage using the potentiometer (see section: Potentiometer).

Figure 17 Position of DC output terminals

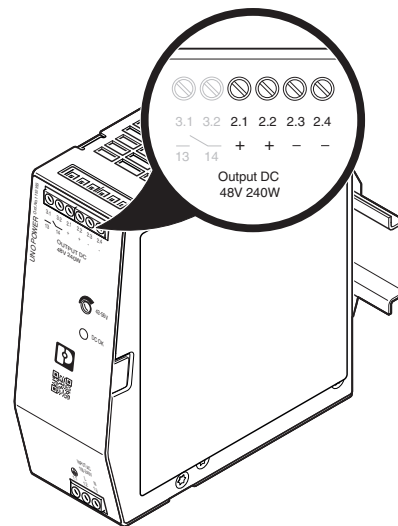

9.4.1 Wiring principle for DC output terminals

The power supply has two separate connection terminal blocks with positive and negative potentials for supplying DC loads. Connect the DC loads to be supplied to these connection terminal blocks.

Figure 18 Wiring principle for DC output terminal blocks

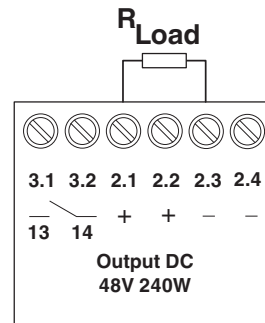

9.4.2 Protection of the secondary side

The power supply is electronically short-circuit-proof and no-load-proof. In the event of an error, the output voltage is limited



If sufficiently long connecting cables are used, fuse protection does not have to be provided for each individual load.

9.5 Connection terminal blocks, floating switch contact (13/14)

There is a floating switch contact on the Output DC connection terminal blocks (connection level 3.x, signal) for forwarding to a superordinate control system.



NOTE: Damage due to impermissibly high contact load

Observe the contact connection data: Max. 30 V AC/DC, 50 mA

Figure 19 Position of the connection terminal blocks, floating switch contact

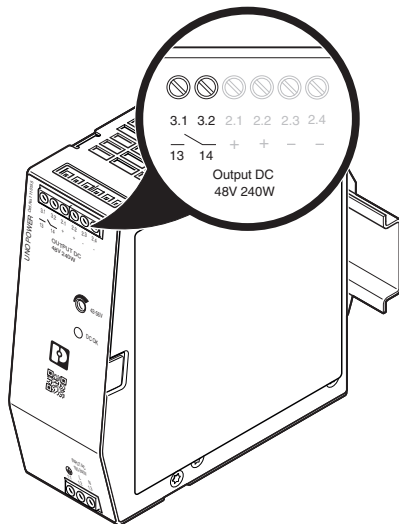

9.5.1 Wiring principle for the floating switch contact

Figure 20 Wiring principle, floating switch contact for forwarding to a superordinate control system

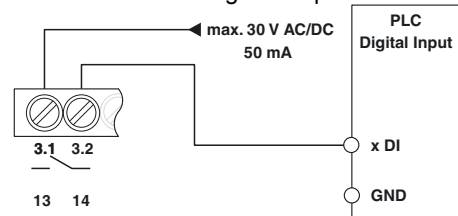

10 Function elements

The functional elements of the power supply, with the exception of the floating switch contact, are situated on the front of the housing of the power supply and are categorized as follows:

- Operating element
- Indication element
- Control element

10.1 Operating element – potentiometer U_{OUT}

The power supply is operated via a stepless potentiometer on the device front. You can use the potentiometer to set the necessary output voltage for supplying the DC load. The axis of the potentiometer has a groove that is marked with an arrow. Turning the potentiometer clockwise increases the output voltage. Turning the potentiometer counter-clockwise decreases the output voltage. The angle of rotation of the potentiometer setting range ($U_{OUT\ min}$ to $U_{OUT\ max}$) is approx. 270°.



NOTE: Damage possible, beware of the potentiometer setting range end stops

The potentiometer setting range is limited via end stops. Accidentally over-torqueing the end stops can damage the potentiometer.

Figure 21 Potentiometer



10.2 Indication element - DC OK LED

A DC OK LED is available for preventive function monitoring of the power supply. Through various different signals, the DC OK LED provides information on the operating status of the power supply.

The possible DC OK statuses are to be found in the following table:

A DC OK LED is available for preventive function monitoring of the power supply. Through various different signals, the DC OK LED provides information on the operating status of the power supply.

DC OK LED	Description
○	Primary-side AC supply is not available, too low, or $U_{OUT} < 0.9 \times U_N$ ($U_N = 48\text{ V DC}$).
●	Power supply in normal mode $U_{OUT} > 0.9 \times U_N$ ($U_N = 48\text{ V DC}$)
⚡	Power supply in case of overvoltage $U_{OUT} > 60\text{ V DC}$ ($U_N = 48\text{ V DC}$)

○ = off, ● = on (green), ⚡ = flashing (green)

Figure 22 DC OK LED



10.3 Control element – floating switch contact (13/14)

A floating switch contact is available for preventive function monitoring of the power supply. The function of the switch contact is assigned to a fixed event. Changing the switch function is not possible.

Process-affecting signals and resistive loads will be switched without limitation. For heavily inductive loads (e.g. a relay), a suitable protective circuit (e.g. a freewheeling diode) is necessary.

The possible switch contact statuses are to be found in the following table:

Contact 13/14	Description
open	Power supply in overload mode $U_{OUT} < 0.9 \times U_N$ ($U_N = 48\text{ V DC}$), power supply in case of overvoltage $U_{OUT} > 60\text{ V DC}$
closed	Power supply in normal operation $U_{OUT} > 0.9 \times U_N$ ($U_N = 48\text{ V DC}$)

11 Output characteristic curves

In normal operation, the power supply supplies the output power in accordance with the device nominal data. If the DC output current supplying the loads increases to an impermissibly high level due to a fault, the power supply disconnects the DC output. The power supply remains in operation, despite the functional disturbance.

The DC OK LED flashes to signal a functional disturbance, and the floating switch contact opens at the same time (see section: Functional elements).

In HICCUP mode, the power supply attempts to return to the conditions present prior to the detected current increase cyclically. This procedure is repeated until the cause of the current increase due to overload or short circuit has been remedied. The power supply then automatically switches back to normal operation. The disturbance signal is withdrawn.

Figure 23 Schematic diagram, HICCUP mode in the event of overload

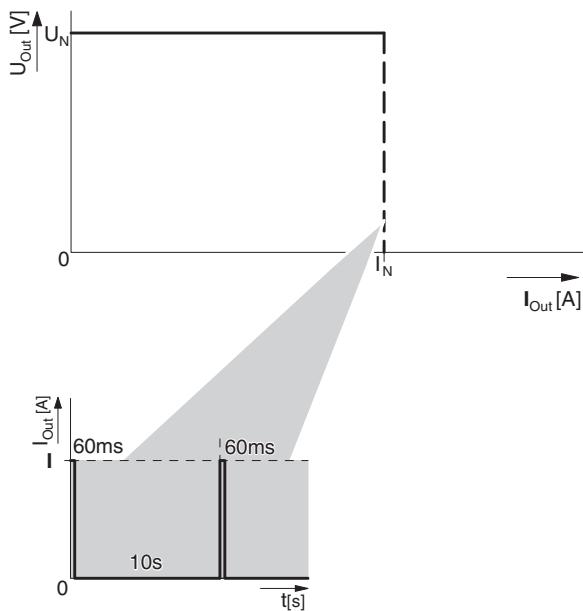

12 Connection versions

Depending on how you intend to use your power supply, there are different ways of connecting the DC output side.

A distinction is made between the following modes of use:

- Power increase through series operation
- Redundancy operation

12.0.1 Series operation

To increase the DC output power in dependence of the output voltage, connect two power supplies in series operation. Only use power supplies of the same type and performance class with identical configurations.

Depending on the common output-side ground reference point of the power supplies, the following DC output voltage potentials are possible:

- +96 V DC
- -96 V DC
- ±48 V DC

Figure 24 Schematic diagram, power increase in series operation

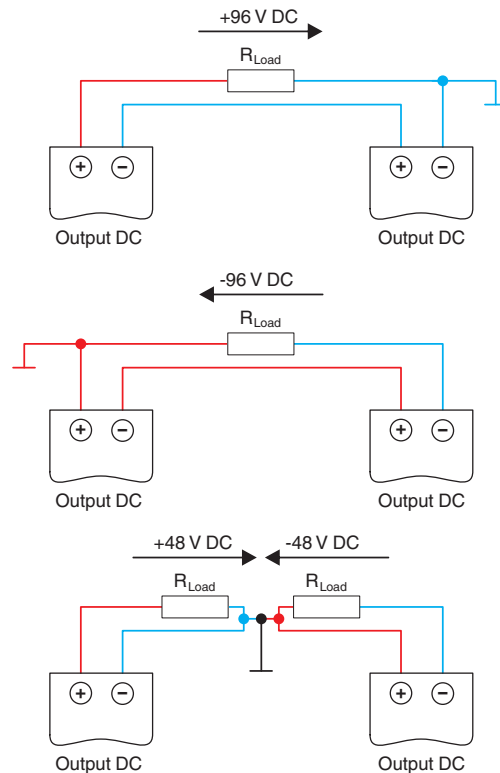

12.1 Redundant operation

Redundant circuits are suitable for the DC supply of systems and system parts which place particularly high demands on operational safety. If the DC load is to be supplied with 1+1 redundancy, two power supplies of the same type and performance class with identical configurations must be used.

In the event of an error, it must be ensured that one of the power supplies is able to provide the total required output power for the DC load to be supplied. The output power required for normal operation is thus provided by two power supplies connected in parallel on the output side. In normal operation, each of the two power supplies will be utilized by up to 50%.



A suitable selection of redundancy modules (active or passive) is to be found in the section: Ordering data, Accessories.

Figure 25 Schematic diagram, 1+1 redundancy with redundancy module (active or passive)

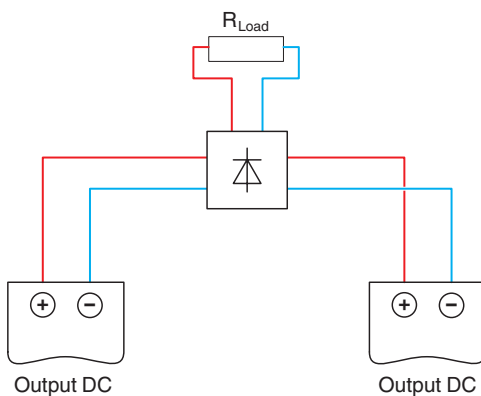

12.2 Fundamental prerequisites for parallel operation (redundancy operation)

In order to ensure correct parallel operation, observe the following rules:

DC output voltage: On each of the power supplies, set the DC voltage in idle mode such that the voltage values are identical. Take any voltage drops occurring due to long cable lengths into consideration.

Cable lengths: To ensure the symmetrical utilization of the power supplies, the connecting cables for supplying the DC load must be identical in length.

Cable cross sections: The connecting cables for supplying the DC load must be rated for the maximum occurring total current of all power supplies. This also applies for redundancy operation, whereby the individual power supply only supplies 50% of the DC load.

Ambient conditions: Select the installation location of the power supplies such that the prevailing ambient conditions are identical. This is of particular importance if the power supplies are installed in different mounting locations. Large temperature differences between the mounting locations have a negative effect on the operating points of the power supplies. This will result in the operating behavior of the power supplies no longer being identical.



If more than two power supplies are connected in parallel for the required power increase, fusing the DC outputs separately is recommended. Use appropriate miniature circuit breakers (MCBs) for this. As an alternative, the DC outputs can be decoupled from one another using redundancy modules (active or passive).

13 Derating

13.1 Ambient temperature

When mounted in the standard mounting position and operated within the permissible temperature range for nominal operation, the power supply provides full output power. If the power supply is operated beyond the temperature range for nominal values, note the reduced output power for the supply of DC loads.



NOTE: Damage due to thermal overload

If the power supply is operated in a different temperature range, only a reduced amount of power can be drawn. Otherwise, the power supply will be thermally loaded disproportionately and the device service life significantly reduced. This thermal load may even damage the power supply such that it is no longer operational.

Figure 26 Output power depending on the ambient temperature

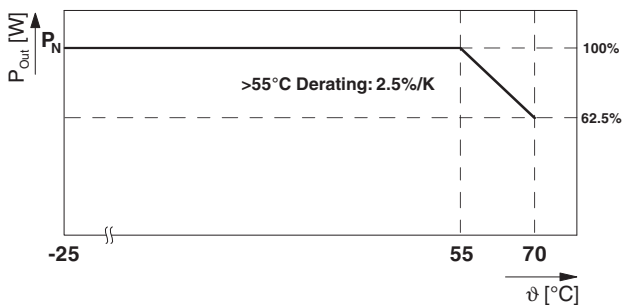

13.2 Installation height

The power supply can be operated at an installation height of up to 2000 m without any limitations. Different data applies for installation locations above 2000 m due to the differing air pressure and the reduced convection cooling associated with this.

Figure 27 Output power depending on the installation height

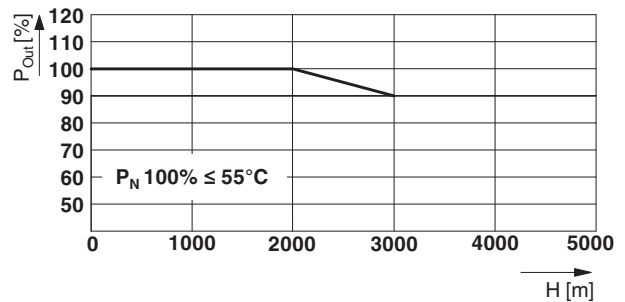

13.3 Position-dependent derating

In order that you can use the nominal power of the power supply without limitation, the power supply should always be mounted in the standard mounting position. Sufficient device-side convection is always assured if the power supply is mounted in the standard mounting position and the necessary restricted areas are observed.



NOTE: Damage due to thermal overload

If the supply is mounted in a different mounting position, only a reduced amount of power can be drawn. Otherwise, the power supply will be thermally loaded disproportionately and the device service life significantly reduced.

13.3.1 Normal mounting position

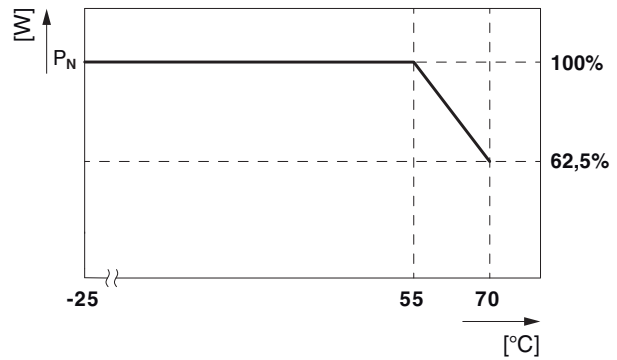
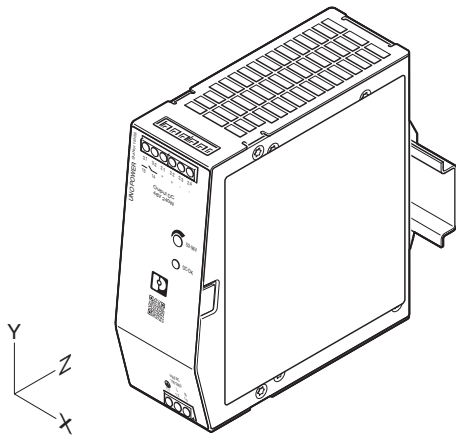

13.3.2 Rotated mounting position 90° Z-axis

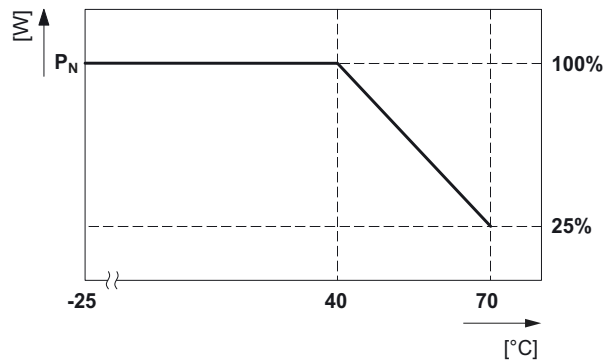
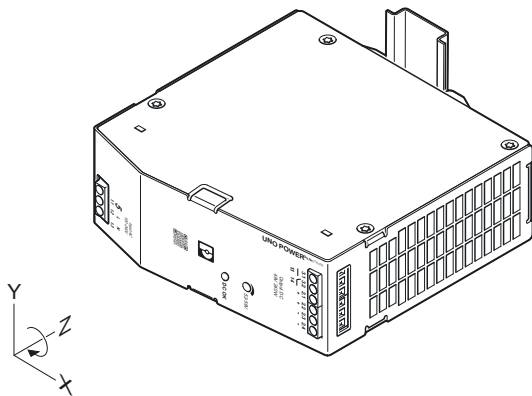

13.3.3 Rotated mounting position 180° Z-axis

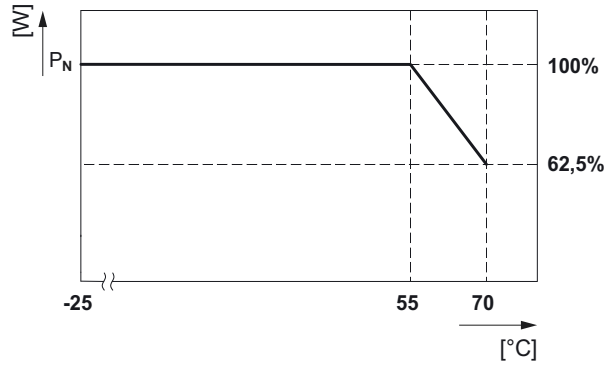
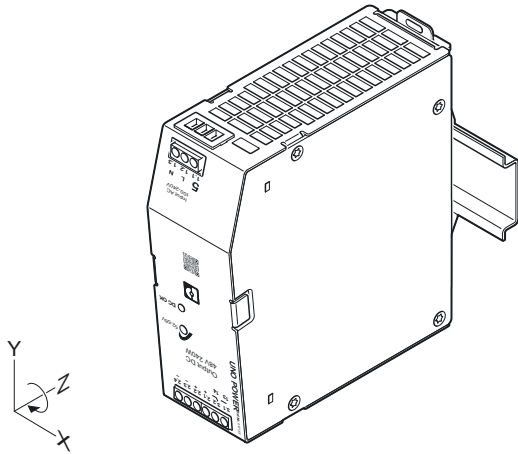

13.3.4 Rotated mounting position 270° Z-axis

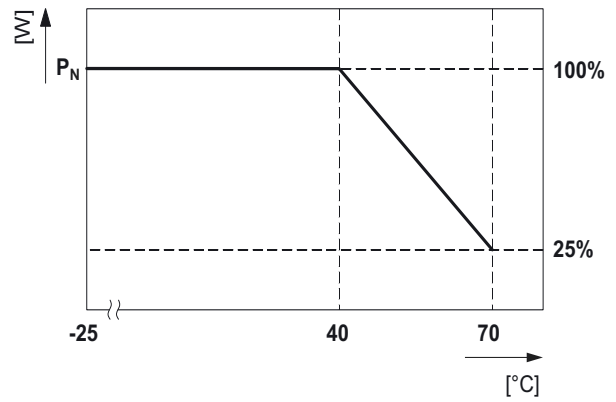
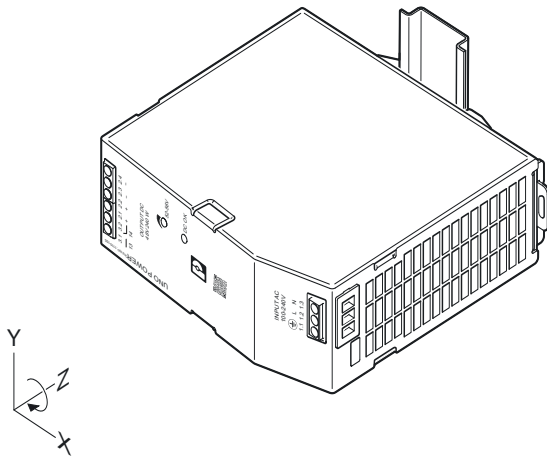

13.3.5 Rotated mounting position 90° X-axis

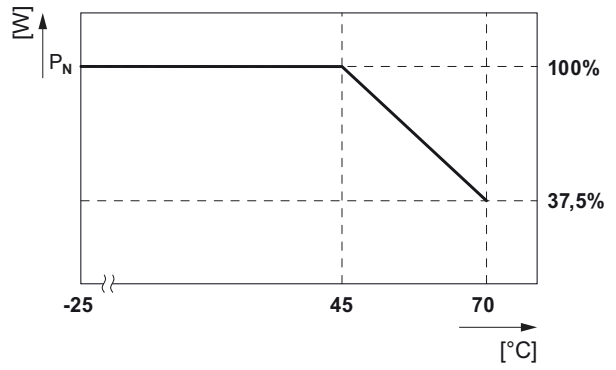
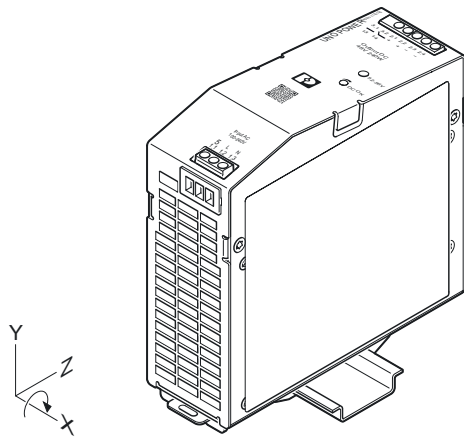

13.3.6 Rotated mounting position 270° X-axis

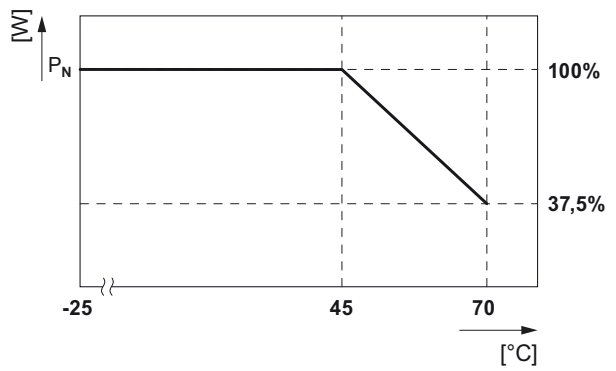
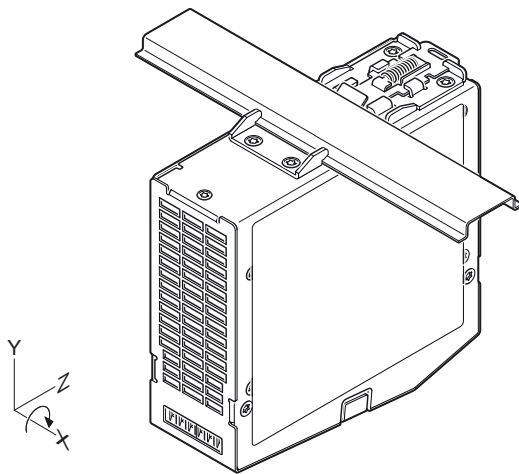

14 Disposal and recycling



Ensure the correct disposal of electronic components

Do not dispose of the power supply as household waste.

Observe the applicable national standards and regulations.



Ensure correct disposal or recycling

Dispose of or recycle packaging material that is no longer needed as household waste.

Observe the applicable national standards and regulations.